

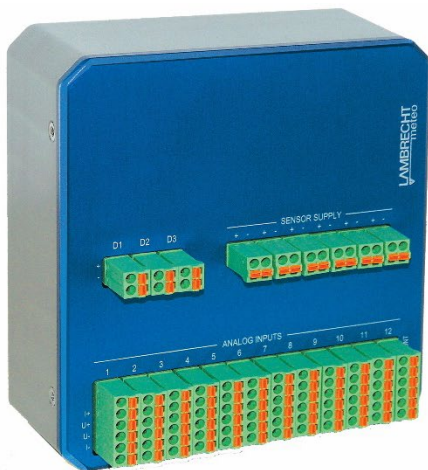

Ser[LOG]

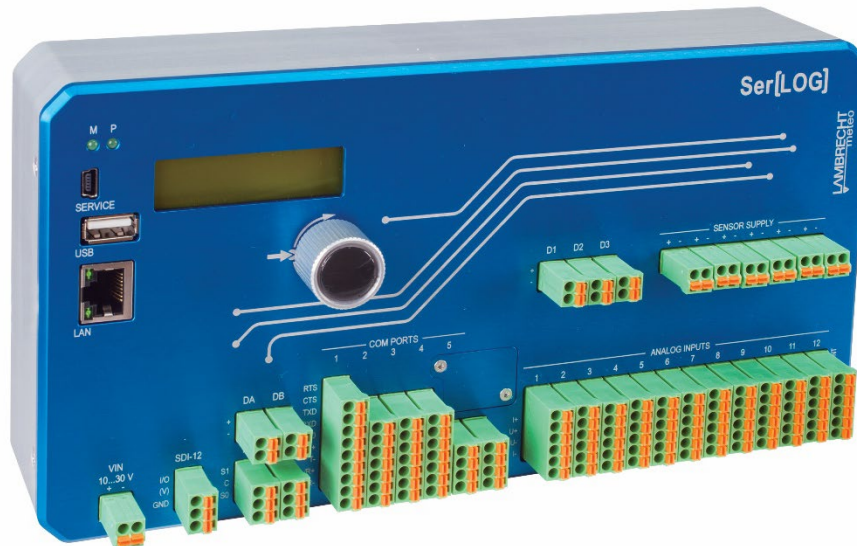

Operator's Manual · Version 17.21

From firmware: 1.200

LAMBRECHT meteo GmbH · Friedlaender Weg 65-67 · 37085 Goettingen
Phone: +49 551 4958-0 · E-Mail: info@lambrecht.net

Chapter Overview

	Page
1 Description Ser[LOG].....	10
2 Wiring - Device Connection.....	17
3 Display Menu	26
4 General Operation of the Ser[LOG]-Commander	32
5 Commissioning / basic configuration.....	40
6 IP Communication.....	69
7 Configuration of the switching outputs and alarms	80
8 Configuration of wind data processing	88
9 SDI-12 Dialogue - Tool	89
10 Firmware Update.....	90
11 Other functions - USB stick readout	91
12 Managing the safety settings.....	92
13 Connection diagrams	100
14 Supported serial protocols	108
15 List of predefined sensors	111
16 Jumper field terminating resistor and interface driver RS485 / RS422.....	117
17 Warranty.....	119
18 Change history.....	120
19 Ser[LOG] sensor assignment	121
20 ASCII character table.....	126
21 Technical data.....	127
22 Disposal.....	129

© Copyright 2017-2021 by LAMBRECHT meteo GmbH, Germany

Copyright & Disclaimer

All information published in this manual's contents is subject to copyright and other laws for protection of intellectual property. The use, storage, modification, copying and distribution of any content require our prior written consent.

All brand and product names mentioned in this manual are registered trademarks and property of their respective owners.

Contents

	Page
1 Description Ser[LOG].....	10
1.1 Description Ser[LOG] for serial sensors.....	12
1.2 Description AnDiMod · Measurement module for analogue / digital sensors	15
1.3 Description Ser[LOG]Plus · Combined logger for serial, digital and analogue sensors	16
2 Wiring - Device Connection.....	17
2.1 Supply voltage	17
2.2 Connection - Serial devices.....	17
2.2.1 Terminal - apparatus with RS485 interface and Modbus RTU.....	17
2.2.2 Special case - Sensors with RS485 interface in talker mode RS422.....	18
2.2.3 Connection - devices with RS422 interface.....	18
2.2.4 Special case sensors with RS422 interface in talker mode on RS485.....	19
2.2.5 Connection – Sensors with SDI-12-Interface	19
2.2.6 Connection - Modem with RS232 interface	20
2.2.7 Connection - PC with RS232 interface	20
2.3 Connection of analogue sensors.....	21
2.3.1 Connection - Sensors with voltage signal.....	21
2.3.2 Connection - Sensors with current signals (0/4...20mA)	21
2.3.3 Connection - Resistance measurement Pt100, Pt1000, potentiometer	22
2.4 Connection of digital sensors	22
2.4.1 Connection - Sensors with status signals.....	22
2.4.2 Connection - Sensors with pulse signals (counter)	23
2.4.3 Connection - Sensors with frequency signals.....	23
2.5 Connection terminals for the supply of sensors	23
2.6 Connection - Relay outputs	24
2.7 Connection - AnDiMod Module.....	24
3 Display Menu	26
3.1 Realtime Values	26
3.2 Data Export.....	27
3.3 Config Import via USB stick.....	27
3.4 Firmware Update	28
3.5 Bluetooth ON	29
3.6 INFO	29

3.7	Display Off	31
4	General Operation of the Ser[LOG]-Commander	32
4.1	Safety properties for Ser[LOG] and Ser[LOG]_Cmd	33
4.2	Configuring the "Ser[LOG] function"	34
4.3	Function „Tools“	37
4.4	Function „Display instantaneous values“	37
4.5	Function “Retrieve measured values“	38
4.6	Function “Display measurement data“	38
4.7	Function “Graphical display of measured values”	38
4.8	Function “Sensor definition“	39
4.9	Function “Actuator definition“	39
4.10	Other functions	40
5	Commissioning / basic configuration	40
5.1	Connecting sensors	40
5.2	Connecting to the supply voltage	40
5.3	Configuration of the Ser[LOG]	41
5.3.1	Basic Station Configuration	41
5.3.1.1	<i>Configuration via Mini-USB Service Interface</i>	<i>41</i>
5.3.1.2	<i>Configuration via USB Bluetooth stick</i>	<i>42</i>
5.3.1.3	<i>Create new configuration</i>	<i>42</i>
5.3.2	Activating AnDiMod Extension Modules	43
5.3.3	Setting the measured value acquisition	43
5.3.3.1	<i>Setting instantaneous values as 3-second moving averages</i>	<i>44</i>
5.3.4	Interface configuration for measured value retrieval and remote configuration	44
5.3.4.1	<i>Communication via network / Internet (TCP/IP)</i>	<i>44</i>
5.3.4.2	<i>Communication via serial interface RS232 / RS485 / RS422</i>	<i>45</i>
5.3.5	Configuration of the sensors	45
5.3.5.1	<i>Configuration Global Radiation Sensors</i>	<i>47</i>
5.3.5.2	<i>Configuration of a pair of vectorially linked wind sensors</i>	<i>47</i>
5.3.5.3	<i>Configuration serial sensors</i>	<i>47</i>
5.3.5.3.1	<i>Configuration of the serial interface for sensors</i>	<i>47</i>
5.3.5.3.2	<i>Setting the data retrieval interval for SDI-12, Modbus RTU and Modbus TCP sensors</i>	<i>48</i>
5.3.5.3.3	<i>Assignment of serial sensors to the measurement channels</i>	<i>49</i>
5.3.5.3.4	<i>Assignment of SDI-12 sensors to the measurement channels</i>	<i>49</i>

5.3.5.3.5	Assignment of Modbus RTU sensors to the measurement channels.....	49
5.3.5.3.6	Assignment of Modbus TCP sensors to the measurement channels.....	50
5.3.5.3.7	Assignment of virtual sensors to the measurement channels.....	50
5.3.5.4	<i>Configuration of sensors with look-up table</i>	51
5.3.5.5	<i>Creating new sensors</i>	51
5.3.5.5.1	Channel type - Analog.....	54
5.3.5.5.2	Channel type - Status.....	56
5.3.5.5.3	Channel type – Digital	57
5.3.5.5.4	Channel type - Modbus	58
5.3.5.5.5	Channel type - SDI-12.....	59
5.3.5.5.6	Channel type - Serial (e. g. NMEA).....	59
5.3.5.5.7	Channel type - Virtual.....	61
5.3.5.5.8	Special function for sensor definition	62
5.4	Displaying instantaneous values	63
5.4.1	<i>Standard instantaneous value display</i>	63
5.4.2	<i>Display of the current electrical raw values</i>	64
5.4.3	<i>Instantaneous value display via UDP</i>	64
5.4.4	<i>Display of moving wind data</i>	65
5.4.5	<i>Error messages of the instantaneous values</i>	65
5.5	Recalling and saving measured values	66
5.6	Display measurement data.....	67
5.7	Display measurement data graphically	67
6	IP Communication.....	69
6.1.1.1	Synchronization of the clock via NTP	70
6.1.1.2	Data Transfer via FTP - Ser[LOG] as FTP Client	70
6.1.1.3	Transmission of measured values via Email / Email alarm	72
6.1.1.4	Setting the Export Format for FTP and Email	73
6.1.1.5	Ser[LOG] & SYNMET_IIA – Neue Features MQTT & HTTPS Post	74
6.1.1.6	Settings MQTT	74
6.1.1.7	Settings HTTPS Post.....	75
6.1.1.8	Data Record Setup Logger Configuration (MQTT / HTTPS Post).....	77
6.1.1.9	Settings for IP communication via mobile radio modem.....	78
6.1.1.10	Setting SMS alarm	79
7	Configuration of the switching outputs and alarms	80

7.1	Process control.....	81
7.2	Cycle control.....	81
7.3	Error monitoring.....	83
7.4	Area monitoring.....	84
7.4.1	Simple area monitoring (OR operation).....	84
7.4.2	Group-related area monitoring (AND operation).....	85
7.5	Modbus relay.....	86
7.5.1	Definition of new Modbus relays.....	87
8	Configuration of wind data processing.....	88
9	SDI-12 Dialogue - Tool.....	89
10	Firmware Update.....	90
11	Other functions - USB stick readout.....	91
12	Managing the safety settings.....	92
12.1	Register user accounts.....	93
12.2	Register "Password guidelines".....	94
12.3	Register Hardware-Software Fusion Key.....	95
12.4	Setting the logger safety register.....	96
12.5	Activating the logger safety.....	99
12.6	Deactivating the safety settings.....	99
13	Connection diagrams.....	100
13.1	Overview - Terminal assignment Ser[LOG]Plus.....	100
14	Supported serial protocols.....	108
14.1	NMEA.....	108
14.2	RPT350.....	108
14.3	PTB330.....	108
14.4	LDWHM_12.....	108
14.5	LD-40.....	108
14.6	CL31 msg 2_base.....	108
14.7	FS11.....	108
14.8	rain[e] 'SDI-12 on RS485'.....	109
14.9	Pluvio 1 DWD.....	109
14.10	Pluvio 2 'M Command'.....	109
14.11	X81.....	109
14.12	VFP-730 'compressed format'.....	109
14.13	15189 'SDI-12 on RS485'.....	109

14.14	LPM Distrometer 'Tel. 6'	109
14.15	Modbus Sensor	109
14.16	SDI-12 (only COM5)	109
14.17	SNAP	110
14.18	GPRS PPP.....	110
14.19	Modbus Actuator / Actor	110
14.20	Ser[LOG] – AnDiMod-Bus (only COM6).....	110
15	List of predefined sensors	111
15.1	Predefined status sensors	111
15.1.1	Standard status sensors.....	111
15.1.2	LAMBRECHT status sensors	111
15.2	Predefined digital sensors	111
15.2.1	Standard digital sensors	111
15.2.2	LAMBRECHT digital sensors	111
15.3	Predefined analog sensors.....	112
15.3.1	Standard analog sensors	112
15.3.2	LAMBRECHT analog sensors.....	112
15.4	Available serial sensors.....	114
15.4.1	LAMBRECHT serial sensors	114
15.4.2	LAMBRECHT SDI-12 sensors	114
15.4.3	LAMBRECHT Modbus sensors.....	114
15.4.4	NMEA sensors.....	114
15.4.5	Additional serial sensors (proprietary).....	115
15.4.6	Virtual sensors.....	116
15.4.7	Virtual Sensors - Special Function Redundancy.....	116
16	Jumper field terminating resistor and interface driver RS485 / RS422	117
16.1	Switching the COM2 to COM6 from RS485 to RS422	118
16.2	Adding terminating resistors for RS485 or RS422	118
17	Warranty	119
18	Change history.....	120
19	Ser[LOG] sensor assignment	121
19.1	Sensor assignment - AnDiMod or Ser[LOG]Plus analog section.....	122
19.2	Sensor assignment - AnDiMod or Ser[LOG]Plus analog section.....	123
19.3	Sensor assignment - AnDiMod or Ser[LOG]Plus analog section.....	124
20	ASCII character table.....	126

21	Technical data.....	127
22	Disposal.....	129

1 Description Ser[LOG]

The Ser[LOG] system family is a universal, scalable data acquisition, data processing and communication platform for professional meteorological data collection.

The Ser[LOG] can detect measured values via its serial 6 (isolated) interfaces and the Ethernet interface.

Implemented protocols:

- SDI-12
- Modbus RTU
- Modbus TCP
- NMEA
- Various proprietary telegrams for various sensors, for example for measuring
 - Air pressure
 - Visibility
 - Cloud height
 - Precipitation

In addition, the Ser[LOG] has two digital status inputs and two relay outputs. A service interface is available in the form of a mini-USB port. To the USB Host (2.0), memory stick for data export and selected Bluetooth stick can be used as a wireless service interface. Both via the Bluetooth stick or via the memory stick configurations and firmware updates can be transferred.

The Ser[LOG] can be extended by additional AnDiMod 1-3 measurement modules. Each AnDiMod includes 12 differentially measured analogue and 3 digital channels. The AnDiMod 1-3 modules differ in their addresses on the Ser[LOG] bus. Upon expansion the sequence of AnDiMod 1-3 must be complied with.

Up to 3 AnDiMod can be connected to a Ser[LOG]. Thereby, above the channels added via the serial interfaces and virtual channels, the Ser[LOG] can be extended with up to 36 analogue and 11 digital channels. A maximum of 60 channels are supported, wherein each respective channel corresponds to one measured parameter. The Ser[LOG]Plus already includes an AnDiMod module with the address 1 in its housing and can be extended by 2 more AnDiMod modules (address 2 and 3) each extension offering up to 36 analogue and 11 digital channels.

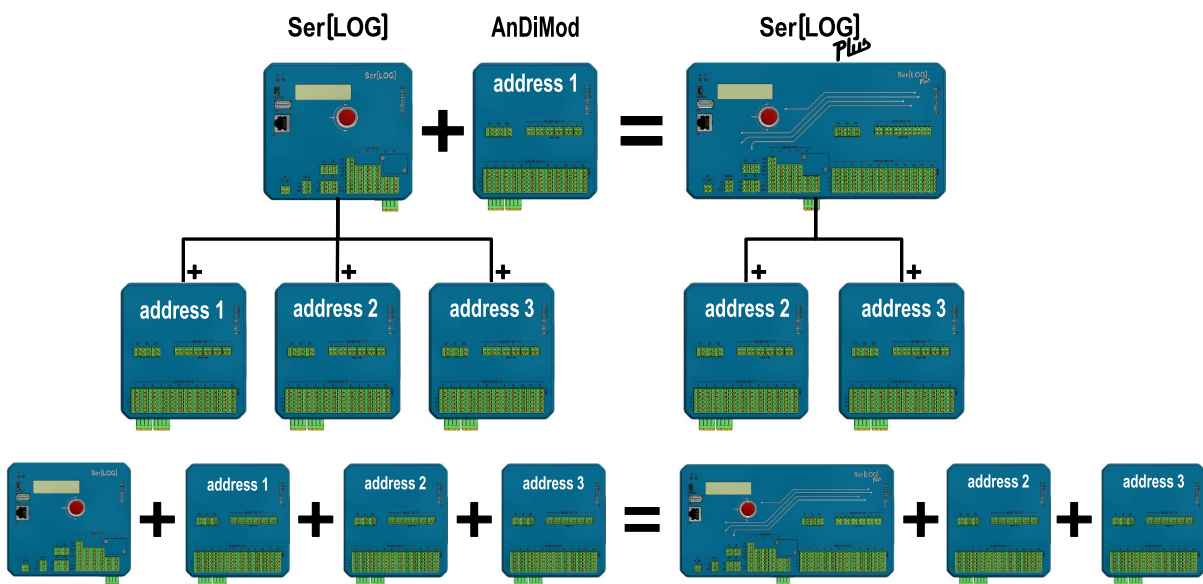

- Ser[LOG]** Data logger for serial sensors
- AnDiMod** Measurement module for analogue and digital sensors
- Ser[LOG]Plus** Combined device Ser[LOG] and 1x AnDiMod in one housing

The configuration of the Ser[LOG] takes place with the "Ser[Log] Commander". This application has a sensor library from which the channels of the Ser[LOG] can be easily and quickly assigned by "point and click" with sensors from the LAMBRECHT product range. In addition, users can add their own sensors and thus extend the sensor library.

Virtual channels like dewpoint calculation or reduction of air pressure can be defined from the existing formula collection or by the formula interpreter.

Regardless of the configuration and the storage interval, the Ser[LOG] stores all measurement values in a ring buffer, which holds data for exactly 1 year. After that, the oldest value is overwritten.

With the MeteoWare CS4 the data collected can be conveniently analyzed. (The MeteoWare CS 4 is not included!)

The communication of the Ser[LOG] with the user's PC is either via

- cable connection (RS232, RS422, RS485)
- network connection (100 Mbps Ethernet) or
- wireless or mobile (GPRS, EDGE, UMTS, HSPA +, LTE)
- USB and Bluetooth (only for service purposes)

A total of 26 simultaneous communications are supported.

In the "push mode" the Ser[LOG] automatically sends the measured data via FTP and / or e-mail Ethernet, WiFi or cellular (2G / 3G / 4G).

The Ser[LOG] can control up to 10 "Switching Channels", each switch a relay and / or send e-mail or SMS messages. The Ser[LOG] provides two built-relays; additionally up to 8 external Modbus relays can be controlled.

1.1 Description Ser[LOG] for serial sensors

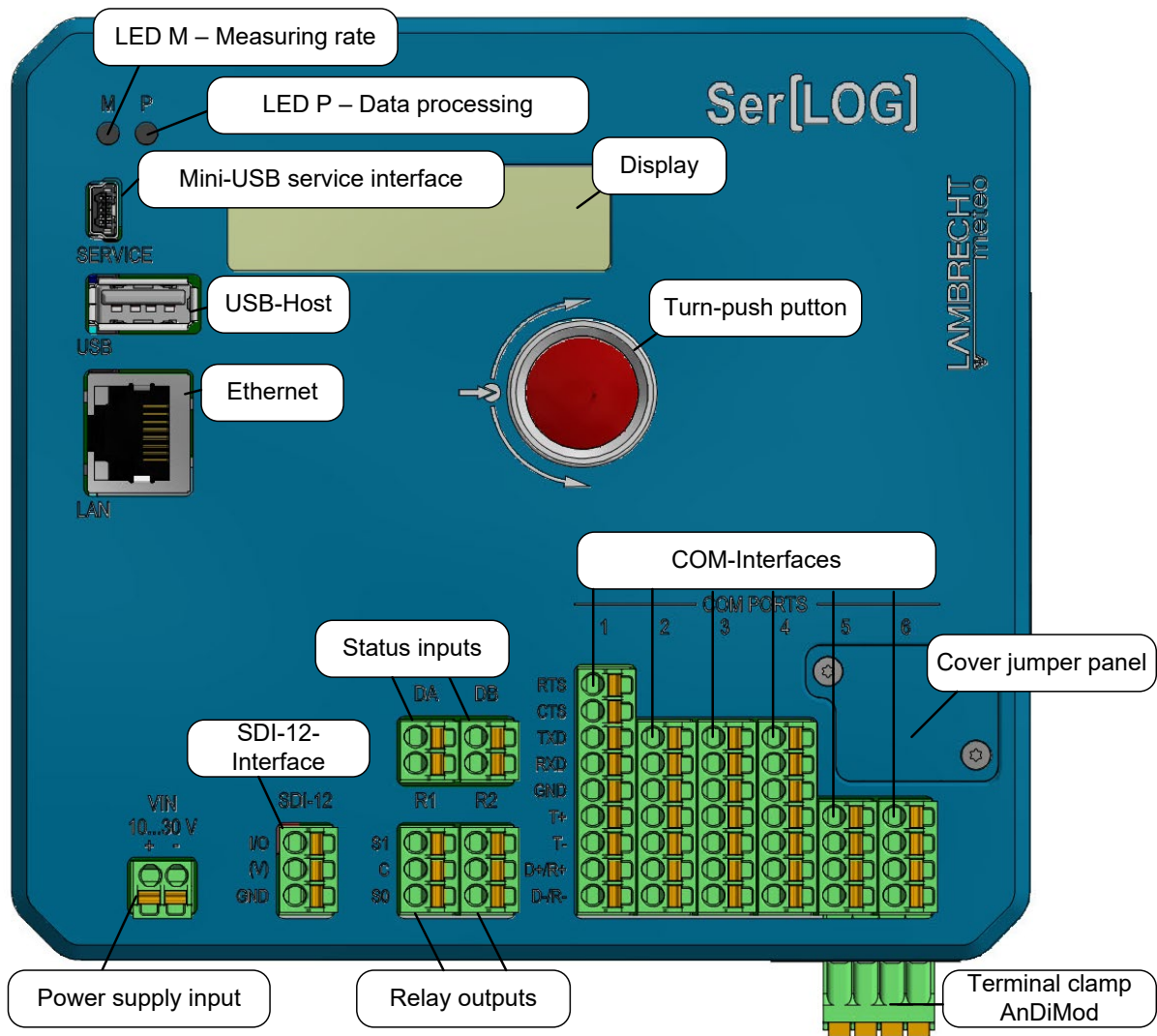

Power supply input

Terminal "VIN" The device can be powered by 10-30 VDC. The connection is protected against reverse polarity. The installed DC / DC-converter are not isolated.

Note: The applied supply voltage is routed through the "Ser[LOG] bus" to the connected AnDiMod measurement modules. The modules also provide this voltage to supply the sensors. This means that for the sensor supply terminals always receive the same voltage as the Ser[LOG] unit.

Turn-push button

The rotary push button enables the following operations of the Ser[LOG]:

- Display of instantaneous values,
- Export of data and Ser[LOG] configuration,
- Import of a Ser[LOG] configuration,
- Update of the device firmware,
- Activation of a Bluetooth stick and
- Reading of device information.

- Display** The two-line LCD display is activated when the rotary push button is operated. After one minute of idle time, the display switches off automatically.
- Mini USB service interface** The mini USB port is used solely to configure and verify the device. This connection is not suitable for permanently connecting the unit to a PC. (Various PCs inadvertently force a reboot of the device when they switch to or from the power saving mode. In this case, an averaging block is lost.)
- USB host** The USB host port is for plugging-in a USB memory stick or a Bluetooth adapter. The Ser[LOG] delivers a maximum of 200 mA via USB. Consumers with higher power consumption are not supported.
- Ethernet** The network connection of Ser[LOG] supports 10 Mbit / s / 100 Mbit / s. The device does not support DHCP server but requires a fixed IP address.
- COM interfaces** The Ser[LOG] has 6 serial ports, which can be partially operated as RS232, RS422 or RS485. Furthermore, Modbus and SDI-12 interfaces are available.

	RS232 hand-shake	RS232	RS422	RS485	Modbus	SDI-12	AnDiMod
COM1	X	X	X				
COM2		X	X	X	X		
COM3		X	X	X	X		
COM4		X	X	X	X		
COM5			X	X	X	X *	
COM6			(X)	(X)	(X)		X *

* separate Klemme • separate terminal
 (X) nicht bei Ser[LOG] Plus • not at Ser[LOG] Plus

When SDI-12 sensors used, the connection runs via the separate SDI-12 terminal on Ser[LOG]. In this case the SDI-12 unit occupies COM5 interface and the COM5 port is disabled.

If the Ser[LOG] is extended with one or more AnDiMod modules, the connection is made via the separate terminal of 4 found on the bottom of the housing. In this case the AnDiMod modules occupy the COM6 interface and the COM6 port is disabled.

The COM1 to COM4 may be configured with the Ser[LOG] -Commander to RS232. An RS232 interface with handshake line is only available on the COM1.

COM2 to COM6 can be switched via jumper RS485 (default) to RS422. The COM1 is not switchable to RS485.

The interfaces can be switched on with the Ser[LOG] Commander and off.

- SDI-12 interface** The "SDI-12" port has 3 terminals. The communication signal (+) is applied to the terminal "IO", at terminal "GND", the mass is connected. If the connection cable of the SDI-12 bus carries the bus voltage, it can be parked on the terminal"(V)". The terminal (V) is not connected to the device's electronics by the factory (dead set). The Ser[LOG] does not supply the SDI-12 bus in the standard version with power. The supply of the SDI-12 bus must take place separately.

- Status Inputs** The two status inputs "DA" and "DB" can be used for registration of states (switch ON / OFF).

Relay outputs	The relays "R1" and "R2" are bistable, potential-free changeover switch. At "C", the signal to be switched is applied. In the idle state there is a switching connection to "S0", in active state to "S1". The relays may be loaded with up to 30 V and 0.5 A.
Cover jumper panel	There is a jumper field under the cover. Via the jumper field of the hardware drivers COM2 may be switched to COM6 from RS485 to RS422 and 120 Ω termination resistors are switched in. See Section 13
LED - M - Measuring rate	The LED "M" flashes on the set measurement cycle. The light-ON-time is analogue to the duration of the measurement. After switching on the Ser[LOG], the LED lights up until the "boot" is complete.
LED – Data processing	LED "P" flashes during data processing. When 10 minutes average values are generated, the LED flashes only every 10 minutes. The lighting duration is analogous to the duration of data processing.
AnDiMod terminal clamp	If the Ser[LOG] is extended with one or more AnDiMod modules, the connection is made via the 4-pin terminal on the bottom of the housing.

1.2 Description AnDiMod · Measurement module for analogue / digital sensors

There are three different extension modules for the Ser[LOG] and Ser[LOG]Plus. The modules AnDiMod 1-3 differ in their address on the Ser[LOG] bus. If a Ser[LOG] system is extended with an AnDiMod module, a prior examination is necessary to determine how many modules have already been connected and that these modules have been assigned with the correct addresses (the numbering follows). The first module (upon extending a Ser[LOG]) must carry address 1. The first module (upon extending a Ser[LOG]Plus) must carry address 2, since AnDiMod with address 1 in Ser[LOG]Plus is already integrated. The respective address of AnDiMod is fixed and cannot be customized by the user.

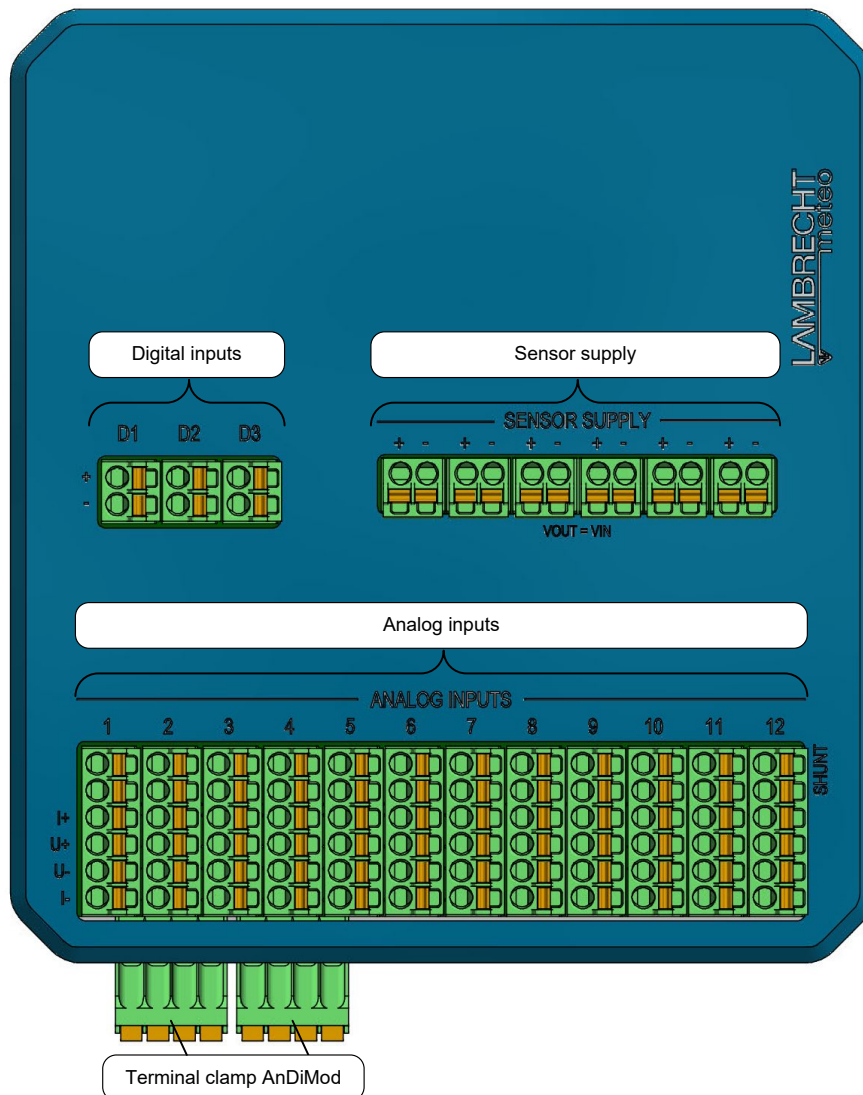

Analog inputs An AnDiMod has 12 universally configurable analogue inputs. The channels can be set for the measuring ranges:

- 5 V bipolar,
- 5V unipolar,
- 50 mV bipolar,
- 20 mA
- 500 ohms
- 5000 ohms.

For the measurement of 20mA signals, a measuring resistor (shunt) must be switched on. This is done by setting a bridge in the upper two terminals.

Digital Inputs The inputs "D1", "D2" and "D3" are for connecting digital sensors. They can be used to capture:

- Status signals (ON / OFF)
- Pulses (counter / precipitation) or
- Frequencies (up to 10 kHz)

Sensor supply There are connection terminals available for supplying up to 6 sensors. The voltage at the terminals corresponds to the supply voltage at terminal VIN with which the Ser[LOG] is supplied. (24 V at the Ser[LOG] means 24 at these terminals VOUT = VIN). The maximum current to the sensor supply for all the terminals together is limited to 0.5 A.

1.3 Description Ser[LOG]Plus · Combined logger for serial, digital and analogue sensors

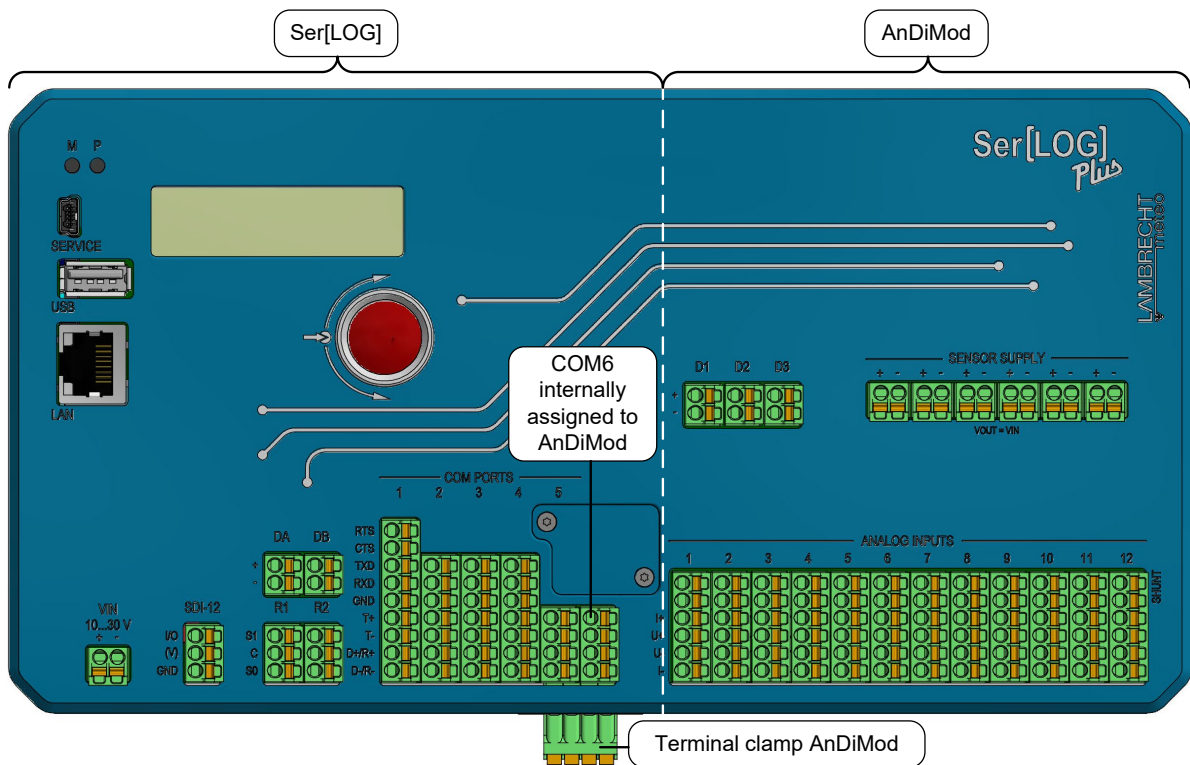

The Ser[LOG]Plus consists of a Ser[LOG] and a AnDiMod module (address 1) in a housing. Controls, interfaces and label are mostly identical. Since the Ser[LOG]Plus already has an integrated AnDiMod module has the COM6 interface is occupied by the AnDiMod module and COM6 terminal (unlabeled) is disabled.

2 Wiring - Device Connection

2.1 Supply voltage

Via terminal "VIN", the Ser[LOG] can be supplied with 10...30VDC. The connection is protected against reverse polarity. The used DC / DC converter is not isolated. Typically, the Ser[LOG] is supplied with 12VDC or 24VDC.

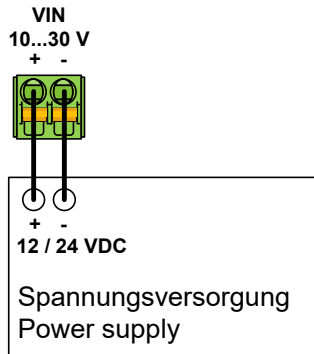

Note: The applied supply voltage is routed through the "Ser[LOG] bus" to the connected AnDiMod measurement modules. The modules pass this voltage on to supply sensors. This means that the sensor supply terminals always receive the same voltage that was applied on Ser[LOG]. $V_{OUT} = V_{IN}$

2.2 Connection - Serial devices

The following devices with serial interface can be connected to the Ser[LOG]:

- Sensors
- Evaluation PC
- Modem
- Modbus relay
- AnDiMod (COM6)

Important note: By default, factory settings the serial ports are disabled. The Ser[LOG] can be reached during initial commissioning only via the mini-USB service interface or a (suitable) Bluetooth stick.

2.2.1 Terminal - apparatus with RS485 interface and Modbus RTU

By default, factory settings the equipment with RS485 interface (e.g. Modbus RTU protocol) can be via the COM port 2-6 connected. The device is delivered so the RS485 hardware drivers for COM ports are enabled through the jumper fields from 2 to 6.

RS485 jumper settings for COM2...6

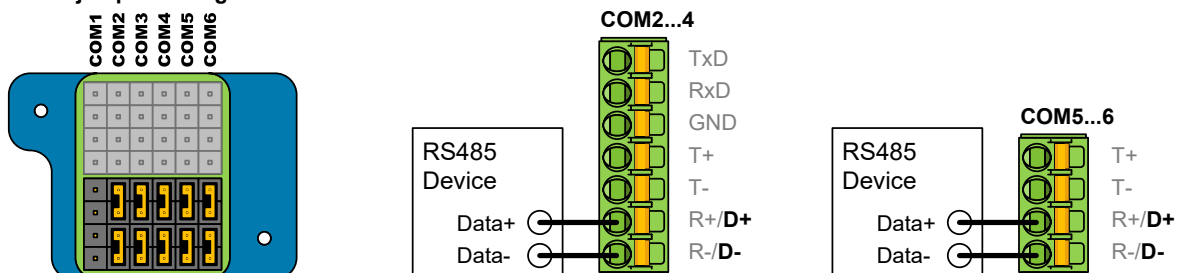

Example of lower jumper field: RS485 hardware driver for COM2 to COM6 activated.

Note: In order to use the occupied COM interfaces, they must be switched on and configured with the Ser[LOG]-Commander.

2.2.2 Special case - Sensors with RS485 interface in talker mode RS422

Some sensors transmit their readings automatically within a fixed time interval; they are operating in the so-called talker mode. LAMBRECHT meteo sensors that have an RS485 interface and are operated in talker mode, can be connected to the Ser[LOG] and to the "R +" and "R" terminal (Read-lines) of a RS422 configured interface.

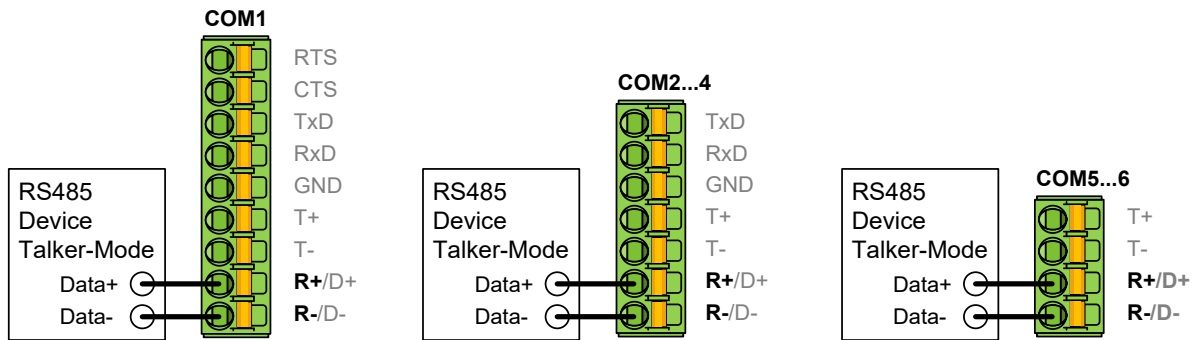

RS422 jumper settings for COM1...6

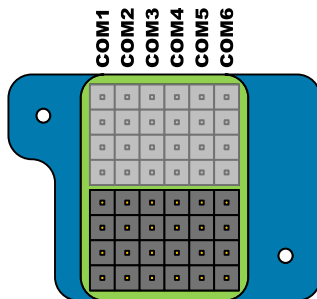

Example of lower jumper field: RS422 hardware driver for COM2 to COM6 activated. (COM1 always RS422)

Note: In order to use the occupied COM interfaces, they must be switched on and configured with the Ser[LOG]-Commander.

2.2.3 Connection - devices with RS422 interface

In the default factory settings devices with RS422 interface can be connected to the COM port 1. On these settings the RS485 hardware drivers are enabled by jumper field for the COM ports 2-6. These can be switched to RS422 hardware drivers by disconnecting the respective jumpers (see picture above).

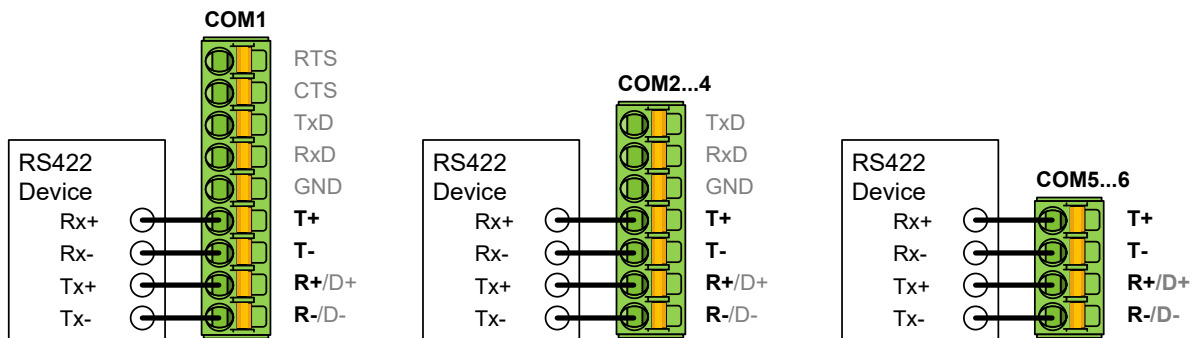

Note: In order to use the occupied COM interfaces, they must be switched on and configured with the Ser[LOG]-Commander.

2.2.4 Special case sensors with RS422 interface in talker mode on RS485

Some sensors transmit their measured values automatically in a fixed time interval; they are then operated in the so-called talker mode. Sensors from LAMBRECHT meteo, which have an RS422 interface that is operated in talker mode, can also be connected to the "D+" and "D-" terminals of an interface configured as RS485 on the Ser[LOG].

Important note: In this case, the "Rx+" and "Rx-" lines of the sensor must not be connected to the correspondingly labelled terminal of the COM interface, because the RS485 hardware driver "R+", "T+" and "R-", "T-" are switched in parallel.

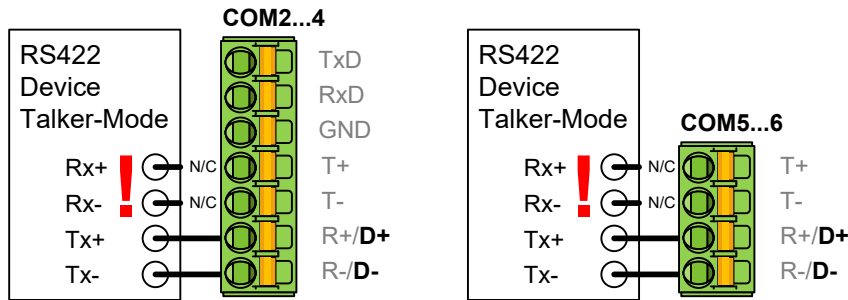

RS485 jumper settings for COM2...6

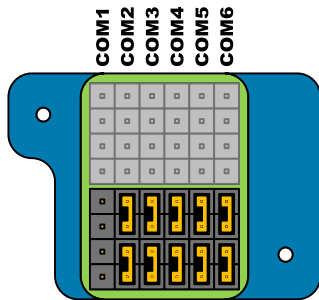

Example of lower jumper field: RS485 hardware driver for COM2 to COM6 activated.

Note: In order to use the occupied COM interfaces, they must be switched on and configured with the Ser[LOG]-Commander.

2.2.5 Connection – Sensors with SDI-12-Interface

SDI-12 sensors are configured in the Ser[LOG] commander via the COM5 interface. The Ser[LOG] supports only a subset from the SDI-12 specification. The Ser[LOG] can only record measured values from sensors that are generated with the CC command.

It is not possible to supply SDI-12 sensors via the Ser[LOG] (standard). The terminal (V) has no function.

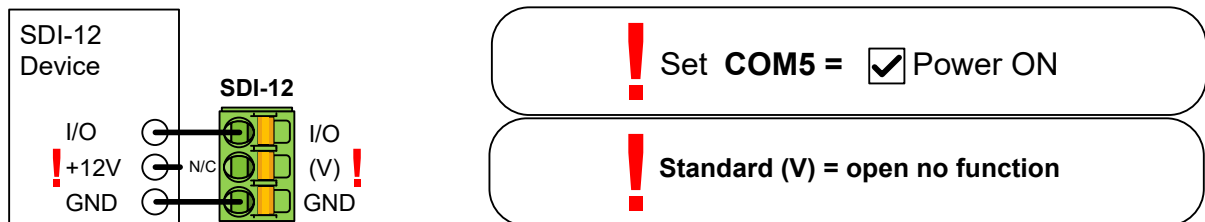

Note: In order to use the SDI-12 interfaces, the COM5 must still be switched on with the Ser[LOG] commander and configured for SDI-12.

2.2.6 Connection - Modem with RS232 interface

Most modems have an RS232 interface. Some modems require RS232 handshake lines for communication with the data logger. These modems can be connected to the COM1 interface. COM2 to COM4 do not have any hand-shake lines.

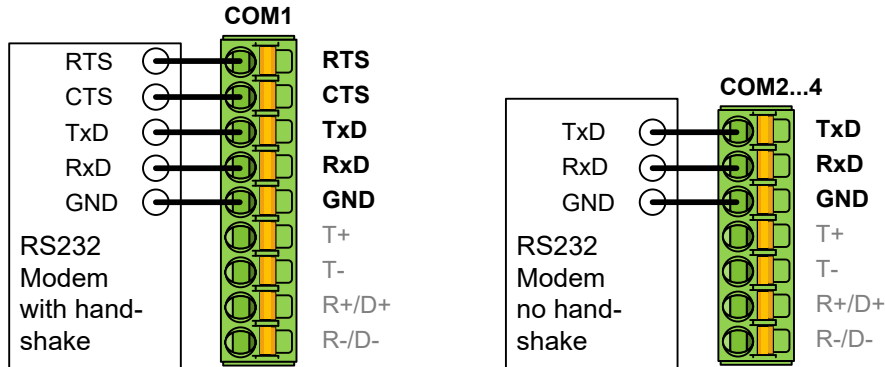

Note: In order to use the occupied COM interfaces, they must be switched on and configured with the Ser[LOG]-Commander.

2.2.7 Connection - PC with RS232 interface

Most modern PCs no longer have an RS232 interface. Nevertheless, the Ser[LOG] can also be connected to a PC via RS232 for configuration and evaluation.

According to the RS232 standard, communication lines must be crossed for connection to the PC. If for communication the RS232 hand-shake line is required, the PC can only be connected via the COM1 interface (the hand-shake lines must then also be crossed). COM2 to COM4 do not have any hand-shake lines.

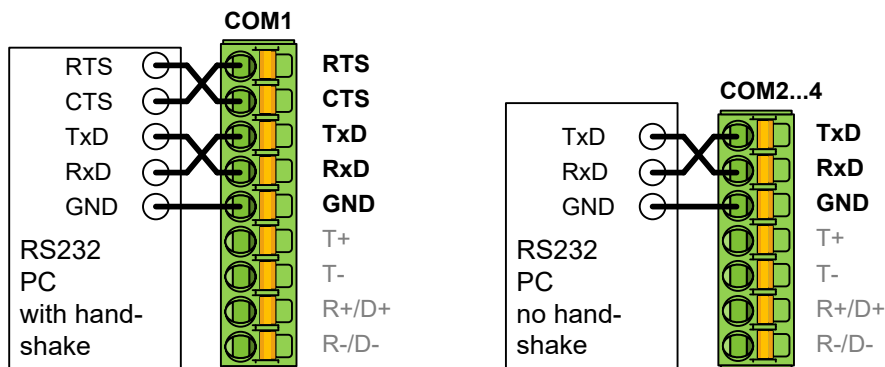

Note: In order to use the occupied COM interfaces, they must be switched on and configured with the Ser[LOG]-Commander.

2.3 Connection of analogue sensors

Analogue sensors can be connected to the Ser[LOG]Plus or the AnDiMod modules. For each AnDiMod module (Ser[LOG]Plus already contains one), 12 analogue signals can be measured. The systems can be expanded to a maximum of up to 36 analogue signals.

The analogue inputs can be used to measure each time:

- 5 V bipolar,
- 5 V unipolar,
- 50 mV bipolar,
- 0/4... 20 mA,
- 500 Ohm and
- 5000 Ohm.

Note: In order for the occupied analogue inputs to be used, they must still be configured with the Ser[LOG]-Commander.

2.3.1 Connection - Sensors with voltage signal

Voltage signals can be measured by the Ser[LOG]Plus or AnDiMod up to a maximum of 5V. If sensors with higher voltages (e. g. 10 V) are to be measured, suitable voltage dividers must be used. For the measurement of millivolts (mV) signals, the analogue inputs can be set to the measuring range $\pm 50\text{mV}$ with the Ser[LOG]-Commander.

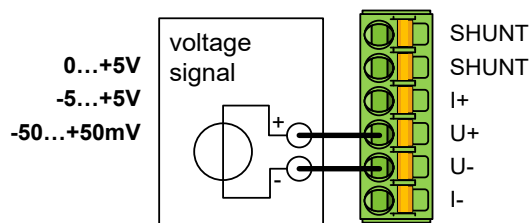

2.3.2 Connection - Sensors with current signals (0/4...20mA)

If sensors with 0...20mA or 4...20mA signals are connected to the Ser[LOG]Plus or AnDiMod sensors, the connection is also made to the "U+", "U-" terminals. In addition, the internal shunt resistor must be connected for the current measurement. The shunt resistor is connected by a bridge between the two upper terminals (marked with "SHUNT").

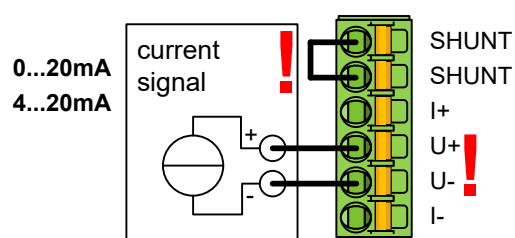

2.3.3 Connection - Resistance measurement Pt100, Pt1000, potentiometer

Ser[LOG]Plus or AnDiMod can measure resistors in the measuring ranges 500 Ω and 5000 Ω . Typical sensors with resistance outputs are e. g. temperature sensors with Pt-100 or Pt-1000 or wind direction sensors with 1000 Ω potentiometers. Pt100 (Pt1000) sensors are usually measured in 4-wire circuit; 3-wire circuit and 2-wire circuit are also possible. The connection of a potentiometer is done in the same way as with the 3-wire circuit.

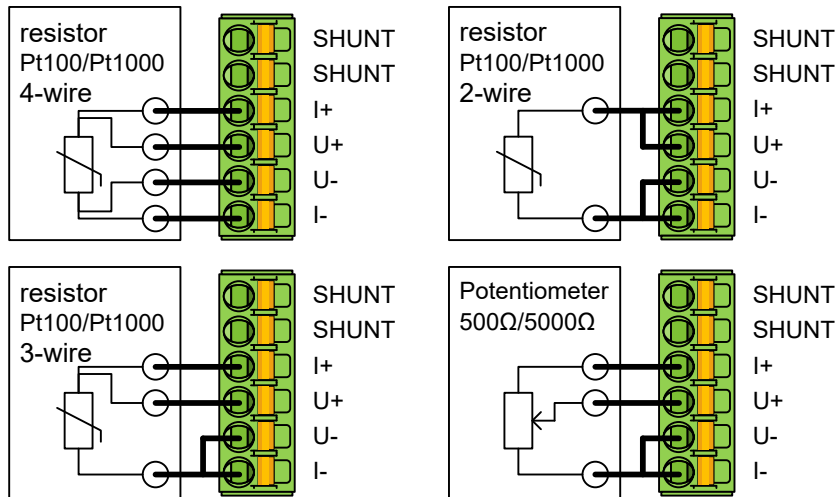

2.4 Connection of digital sensors

The Ser[LOG] comes with 2 digital inputs "DA" and "DB" for the measurement of states. In addition, Ser[LOG]Plus or AnDiMod each have 3 digital inputs "D1", "D2" and "D3" for the measurement of:

- Statuses (status)
- Impulses
- Frequencies

2.4.1 Connection - Sensors with status signals

Status signals can be measured/registered on the "DA" and "DB" terminals of the Ser[LOG]Plus or AnDiMod and on the "D1", "D2" and "D3" inputs of the Ser[LOG]Plus or AnDiMod.

Note: Active status signals with [log. 0] at <2 V and [log. 1] at >2.5 V... 30 V, cannot be measured with the digital inputs "DA" and "DB"!

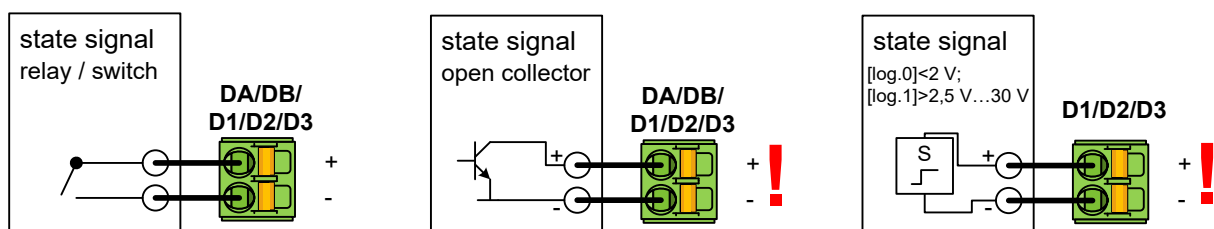

Note: For sensors with open collector (OC) output, the polarity of the connection terminals must be observed!

2.4.2 Connection - Sensors with pulse signals (counter)

Sensors with pulse outputs (e. g. precipitation meter with tilting scale) can be connected to the inputs "D1", "D2" and "D3" of the Ser[LOG]Plus or AnDiMod. **Note:** No pulses can be measured with the digital inputs "DA" and "DB"!

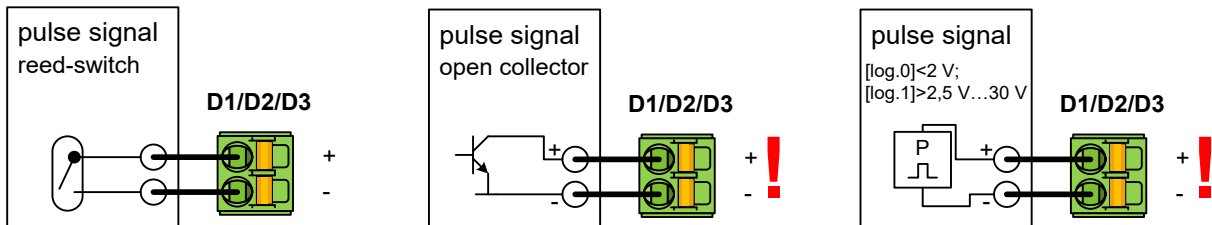

Note: For sensors with open collector (OC) output, the polarity of the connection terminals must be observed!

2.4.3 Connection - Sensors with frequency signals

With Ser[LOG]Plus or AnDiMod, frequencies up to 10kHz can be measured at the inputs "D1", "D2" and "D3".

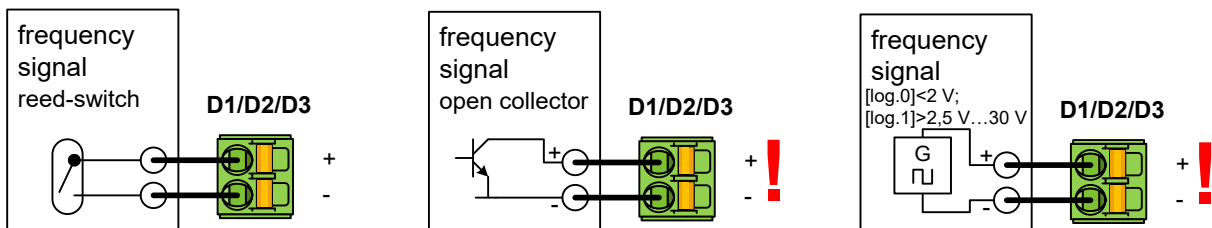

Note: For sensors with open collector (OC) output, the polarity of the connection terminals must be observed!

2.5 Connection terminals for the supply of sensors

"SENSOR SUPPLY", which is applied to the Ser[LOG]. VIN = VOUT (VIN=10... 30 VDC) applies.

Important note: Do not remove more than 0.5 A in sum from all supply terminals (max. 18)!

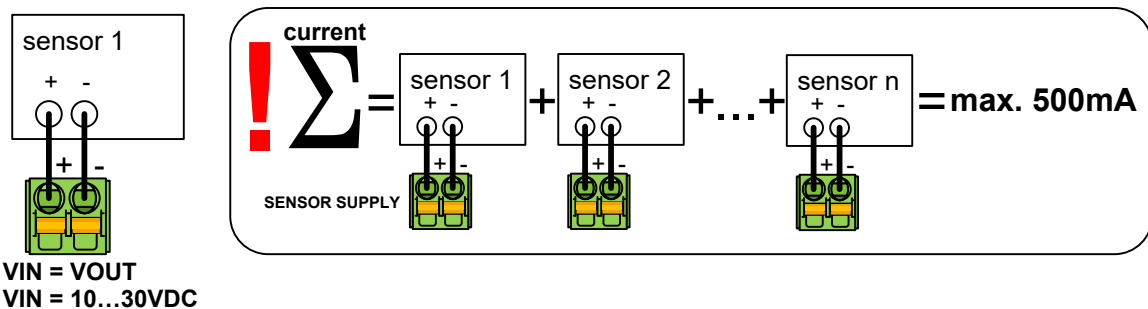

2.6 Connection - Relay outputs

The Ser[LOG] has 2 switching outputs "R1" and "R2" in the form of two-way switch relays. Warnings and alarm messages can be issued via the relays. See also chapter 7.

Important note: The relays may be loaded with up to 30 V and 0.5 A.

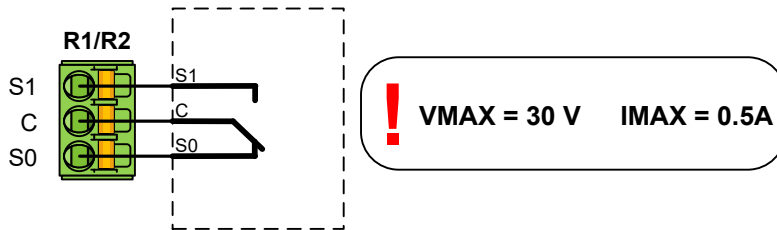

The relays "R1" and "R2" are bistable, potential-free change-over switches. The signal to be switched is applied to "C". In idle state (Log 0) there is a switching connection to "S0", in switched state (Log 1) there is a switching connection to "S1".

2.7 Connection - AnDiMod Module

Ser[LOG] and Ser[LOG]Plus can be extended by additional measurement modules AnDiMod. Each AnDiMod contains 12 differential measuring analogue channels and 3 digital channels.

The connection is made via the Ser[LOG] bus. The AnDiMod modules occupy the COM6 interface and are no longer available for other devices. As soon as the AnDiMod module is activated via the Ser[LOG]-Commander, the COM6 terminal on the front panel is deactivated.

The Ser[LOG]-Bus is available for all devices of the Ser[LOG] family and is located at the bottom of the housing. The 4 terminals are used to connect the power supply and the data lines.

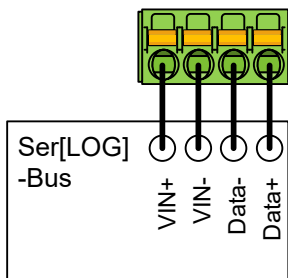

There are three different AnDiMod expansion modules. The modules AnDiMod 1-3 differ in their address on the Ser[LOG]-Bus. If a Ser[LOG] system is to be extended by an AnDiMod, it is necessary to check beforehand how many modules have already been connected and to select the corresponding module with the correct address (numbering following). The first module that can be used to expand a Ser[LOG] must have the address 1. The first module that can be used to expand a Ser[LOG]Plus must have the address 2, since an AnDiMod with the address 1 is already integrated in the Ser[LOG]Plus. An AnDiMod module with address 3 can only be connected to the Ser[LOG] if the AnDiMod modules with address 1 and address 2 have already been connected to the Ser[LOG] bus. If a module is missing in the sequence, this leads to a system error and the Ser[LOG] does not work!

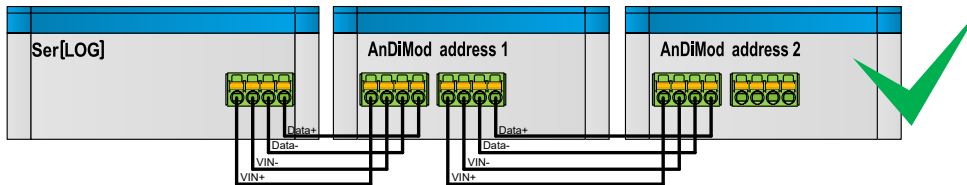
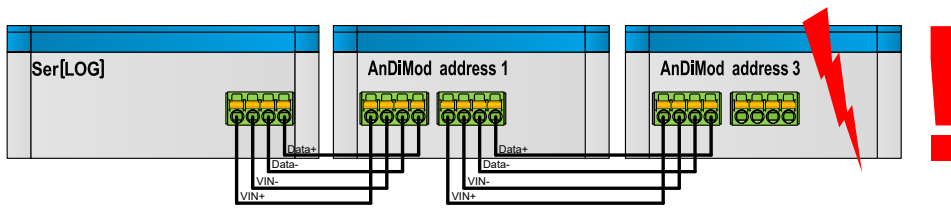

The respective address of the AnDiMod is fixed and cannot be adjusted by the user!

Up to 3 AnDiMod can be connected to one Ser[LOG]. This allows the Ser[LOG] to be expanded to up to 36 analogue channels and 11 digital channels.

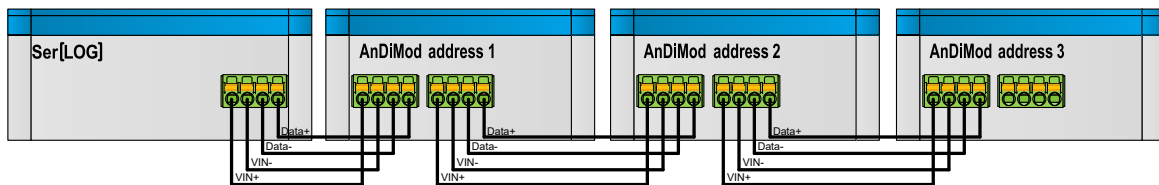
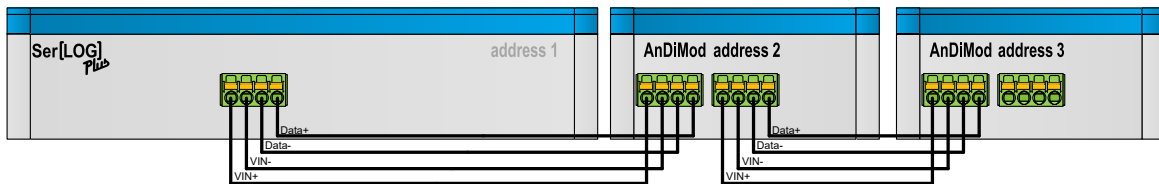

The Ser[LOG]Plus already contains an AnDiMod module (address 1) in its housing and can be extended by 2 additional AnDiMod up to 36 analogue channels and 11 digital channels.

Device / device combination	Communication Interfaces	Serial interfaces	Ana- logue in- puts	Digital inputs
Ser[LOG]	1 x Ethernet 1 x USB host 1 x USB client	6	0	2
Ser[LOG] + AnDiMod 1 or Ser[LOG]Plus		5	12	2+3
Ser[LOG] + AnDiMod 1 + AnDiMod 2 or Ser[LOG]Plus + AnDiMod 2		5	24	2+6
Ser[LOG] + AnDiMod 1 + AnDiMod 2 + AnDiMod 3 or Ser[LOG]Plus + AnDiMod 2 + AnDiMod 3		5	36	2+9

Note: Do not connect more than 3 AnDiMod to the Ser[LOG] resp. 2 AnDiMod to the Ser[LOG]Plus.

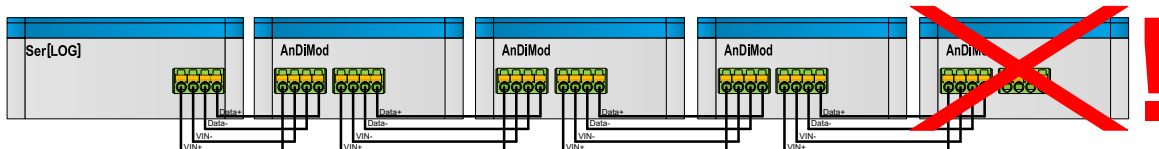
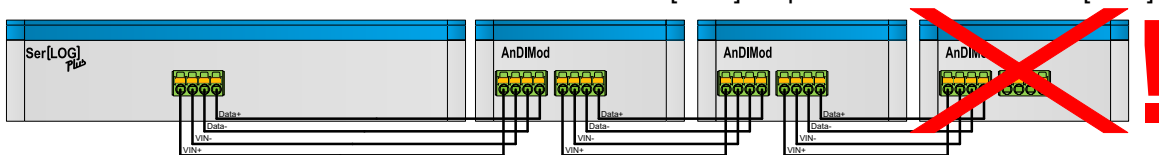

3 Display Menu

The Ser[LOG] has a rotary pushbutton and a two-line LCD display. During normal measuring operation the display is switched off.

Basic display:

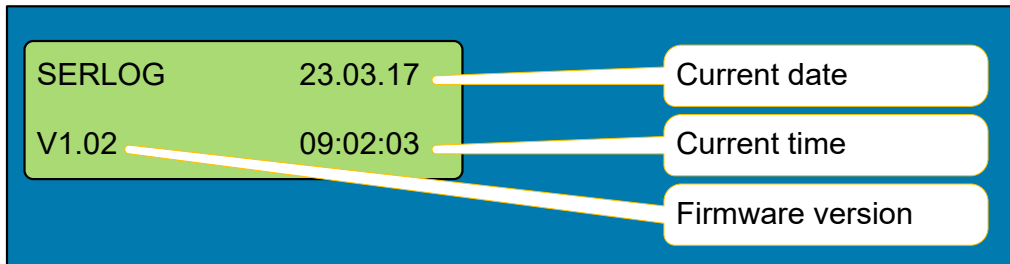

The display is switched on by pressing the rotary pushbutton and you can scroll through the following functions by turning the rotary pushbutton:

Choices:

- **Logon ***
- **Logoff ***
- **Real-time Values / Instantaneous values**
- **Data Export / Data export to a USB stick**
- **Config Import / Importing a configuration from a USB stick**
- **Firmware Update / Firmware update via USB stick**
- **Bluetooth ON / Activating a Bluetooth stick for service use**
- **INFO / Display device information**
- **Display Off / Disable display**

*) only available if the safety system is activated

To select a function, press the rotary pushbutton. The corresponding functions are described below.

Note: If no further input is made for 1 minute, the display will automatically switch off again. If the rotary pushbutton is pressed, the display starts up again in the output menu.

3.1 Realtime Values

The menu item "Realtime Values" displays the current measured values of the configured sensors.

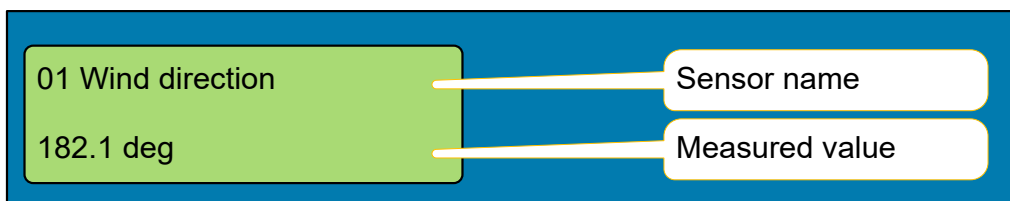

By turning the rotary pushbutton, it is possible to switch between the individual sensors. The number of the measuring channel (01), the configured sensor designation and the current measured value are displayed.

3.2 Data Export

With "Data Export", measured values can be transferred to a inserted USB stick within a freely selectable period of time (in days). In the following example, all collected measured values are read out, which occurred in the period from "01.01.2017" to "31.01.2017".

The screenshot shows a blue background with a light green rounded rectangle containing two rows of text. The first row is 'From: 01.01.17' and the second row is 'To: 31.01.17'. To the right of these fields are two white rounded rectangles with black text. The top one says 'Start date' and the bottom one says 'End date'. Yellow lines connect the callouts to the date fields.

By pressing the rotary pushbutton, you can switch to the respective entry fields TT. MM. JJ (TT=day, MM=month, JJ=year). The respective digits can be set by turning the rotary pushbutton.

When all necessary data is set, a USB memory stick is required.

Note: The input cannot be cancelled. If an incorrect date has been set by mistake, wait 1 minute until the display switches off automatically. The Ser[LOG] is then in the basic menu and the input can be repeated.

The screenshot shows a blue background with a light green rounded rectangle containing the text 'Insert USB Stick'.

The data is exported after inserting the USB stick. The directory "serlog" is created on the stick.

Note: If a directory "serlog" already exists on the stick, its contents will be deleted! The data files and the configuration file are stored in the directory. The USB memory can be read with the Ser[LOG]-Commander or the LAMBRECHT MeteoWare CS-4.

3.3 Config Import via USB stick

ATTENTION! When importing a new configuration via USB stick, all previously collected measured values are automatically deleted!

The configuration to be imported can have been saved by a Ser[LOG] via the "Data Export" function on the USB stick or was created using the Ser[LOG]Commander. The configuration file "serlog cfg" must be stored on a USB memory stick in the "serlog" directory. The import is started by the **Config Import** function.

The screenshot shows a blue background with a light green rounded rectangle containing the text 'Enter Password' and '000000'.

To prevent a configuration from being accidentally imported, a password is prompted. The password is always the current date of the Ser[LOG] in the format TTMMJJ (TT=day, MM=month, YY=year), e. g. 310117 on 31.01.2017.

You can switch to the respective input fields by pressing the rotary pushbutton. The respective digits can be set by turning the rotary pushbutton. When all necessary data is set, a USB memory stick is required.

Note: The input cannot be cancelled. If an incorrect password has been set by mistake, the function is aborted, and the display returns to the basic menu.

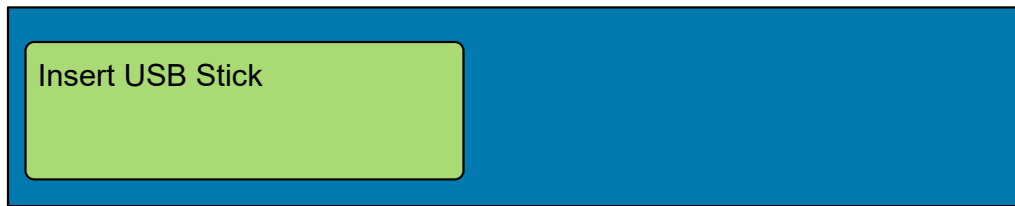

After inserting the storage medium, you will be prompted: "Update?" y/n left / right

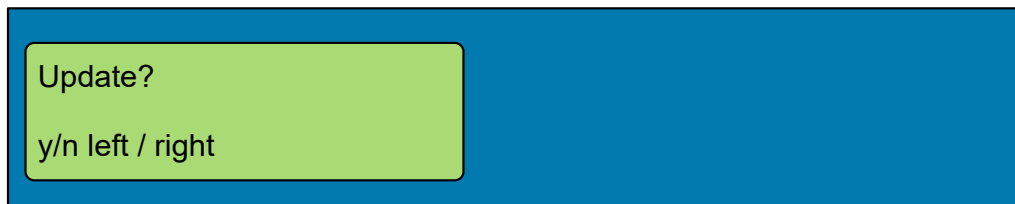

The desired option can be selected by turning the knob:

- Turning to the left (counterclockwise): "YES"
- Turning to the right (clockwise): "NO".

After the configuration has been imported, the CPU restarts automatically.

3.4 Firmware Update

Via the menu item "Firmware Update" a new firmware can be loaded into the Ser[LOG] with a USB stick.

The new firmware must be stored in the root directory of the USB stick. The function Firmware Update is called up on the Ser[LOG]. The device reports in:

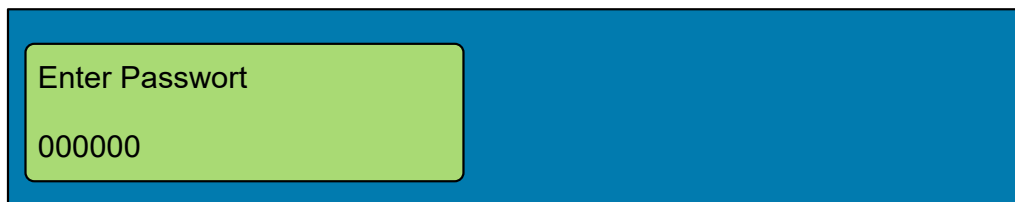

To prevent a configuration from being accidentally imported, a password is prompted. The password is always the current date of the Ser[LOG] in the format JJMMTT (JJ=Year, MM=Month, TT=Day), e. g. 170131 on 31.01.2017.

You can switch to the respective input fields by pressing the rotary pushbutton. The respective digits can be set by turning the rotary pushbutton. When all necessary data is set, a USB memory stick is required.

Note: The input cannot be cancelled. If an incorrect password has been set by mistake, the function is aborted, and the display returns to the basic menu.

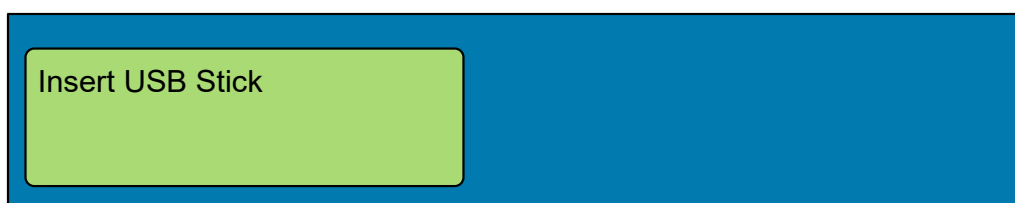

After checking the firmware on the storage medium, you are asked whether the current firmware (e. g. "V1.01") should be replaced by the new firmware (e. g. "V1.02").

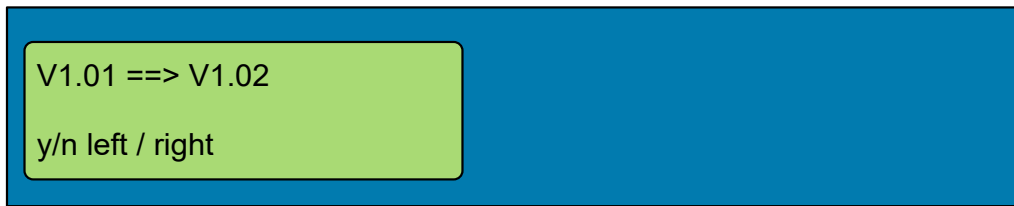

The desired option can be selected by turning the knob:

- Turning to the left (counterclockwise): "YES"
- Turning to the right (clockwise): "NO".

After the firmware update has been loaded, the CPU restarts automatically.

3.5 Bluetooth ON

For service purposes, a USB Bluetooth adapter can be used as a "temporary wireless service interface" for communication with the configuration software Ser[LOG]-Commander via the menu item "Bluetooth ON". At present, the Ser[LOG] only supports Bluetooth sticks with a Bluetooth chip from CSR.

Note: This type of connection is not suitable for permanent connections.

For the connection, the Bluetooth interface must be activated on the PC and the Ser[LOG] (logged in with its station name) must be connected to the PC. The PC asks for the identification of the device to be connected. The identification code is "0000".

After successful coupling, there are 2 serial COM interfaces available on the PC, one "incoming" and one "outgoing" (see Bluetooth settings "COM ports"). Select the "Outgoing" COM interface for the connection.

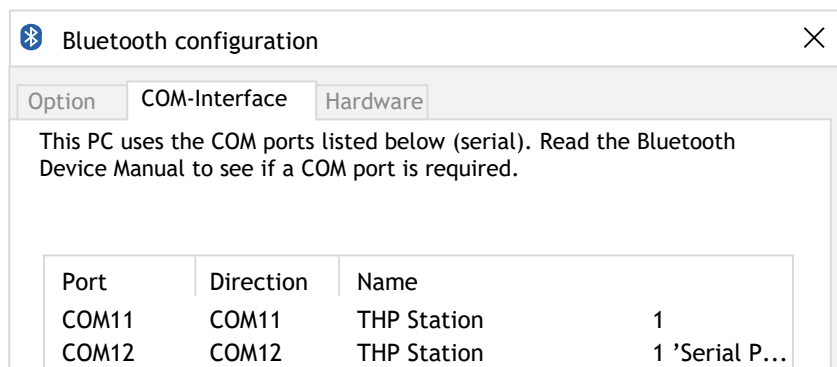

While a Bluetooth adapter is connected, communication with other "wireless" devices (e. g. modem for GPRS / LTE / e-mail, FTP, SMS) cannot be carried out. The Bluetooth connection is switched off again by pressing the rotary pushbutton again or by removing the adapter.

3.6 INFO

The Info function can be used to query the station number (station ID), the current firmware version and the time of the last configuration in the format JJMMTTT/hhmmss (JJ=year, MM=month, TT=day, hh=hour, mm=minute, ss=second).

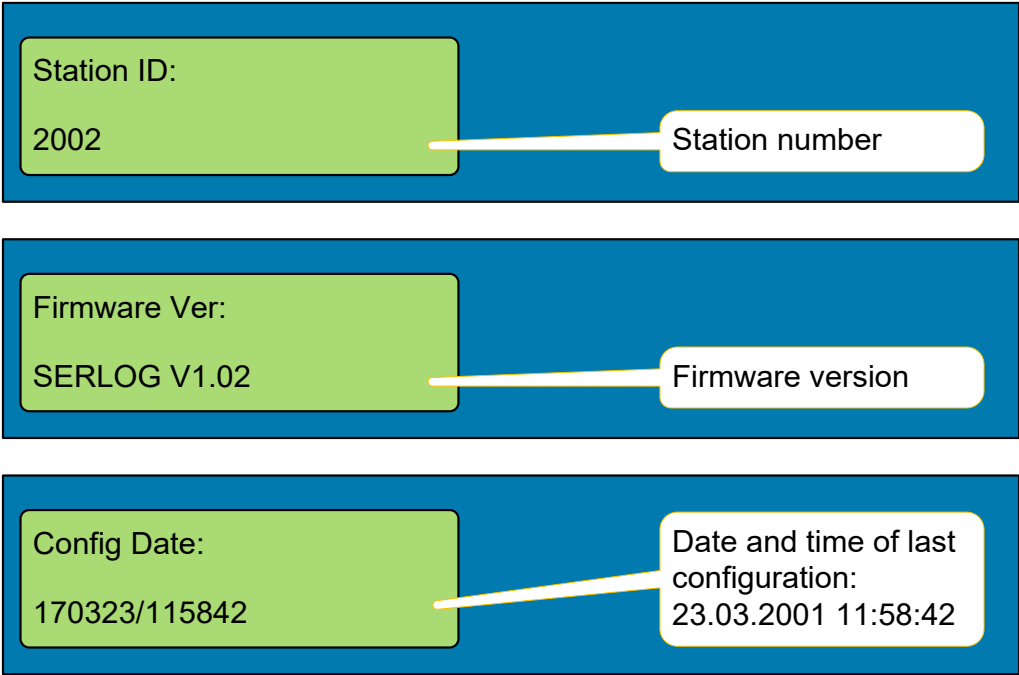

Station: ID:
2002 < Station number

Name: Goettingen
Ser[LOG] 1 < Station number

SKF:
SKF 1212a < Circuit diagram number

Firmware Ver:
Ser[LOG] V1.200 < Firmware version

Config Date:
310322/212944 < Date and time of the last configuration

MAC Address:
00:50:c2:cd:04:56 < MAC address of the Ethernet adapter

IP Address:
192.168.100.179 < IP address of the Ethernet adapter

SubNet Mask:
255.255.255.0 < Subnet mask of the Ethernet adapter

Gateway: 192.168.100.100	< Gateway address for Ethernet adapter
SNAP Port: 4648	< Port for SNAP protocol
UDP Port: 4649	< Port for UDP Realtime Stream
HTTP Port: 8080	< Access to the real-time page
Firmware AM: 0061	< Firmware version co-processor in AnDiMod

3.7 Display Off

The menu item "Display Off" switches the display off until the rotary pushbutton is pressed again.

Logon:

This menu item is used to enable the operating unit of the Ser[LOG].

Enter Password
000000000000

By pressing the rotary pushbutton, you can switch to the respective input fields. The respective digits can be set by turning the rotary pushbutton. When all the required data have been set, Ser[LOG] signals:

Logon
Done

As of now, all menu items are available.

Logoff:

Activating this menu item locks the operating unit of Ser[LOG].

You can activate this function by pressing the rotary pushbutton.

Ser[LOG] returns:

Logoff
Done.

4 General Operation of the Ser[LOG]-Commander

Ser[LOG] and Ser[LOG]Plus are put into operation, configured, and tested with the configuration tool "Ser[LOG]-Commander".

Ser[LOG]_Commander is a 32 bit Windows application that can be used under the operating systems Windows XP to Windows 10. The application can be used from a USB memory stick. Installation on the PC is not necessary.

If you want to copy the Ser[LOG]-Commander to a USB stick or a PC, all files contained in the Ser[LOG]_Cmd folder must be copied as well. The files must always be in the same shared directory.

You start the Ser[LOG]-Commander by calling the "SerLog_Cmd.exe". After starting, the following main menu is displayed:

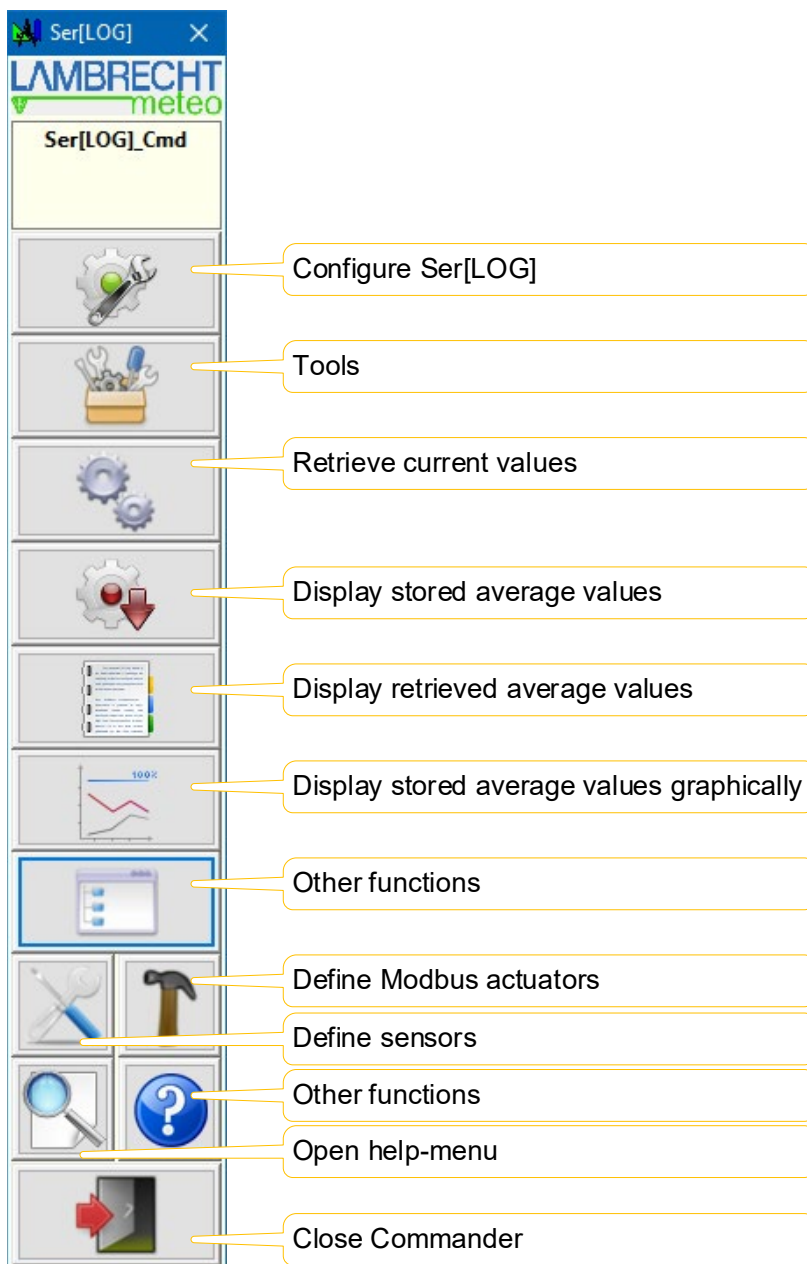

For easier navigation, the control elements of the Ser[LOG]-Commander are provided with explanatory tooltips, which appear as soon as you hold the cursor over the respective element.

4.1 Safety properties for Ser[LOG] and Ser[LOG]_Cmd

When starting Ser[LOG]_Commander, the user is asked to identify himself.

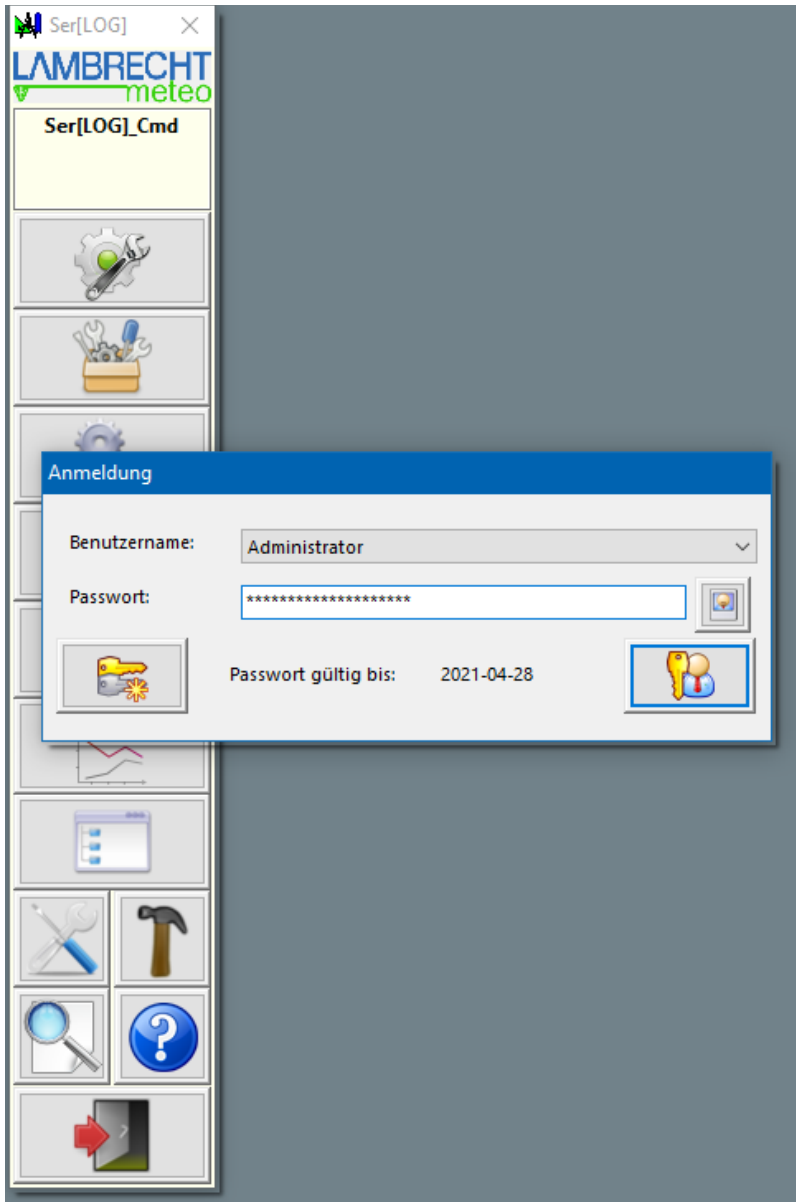

Since the Ser[LOG]_Commander is a tool that grants full access to the logger, the administrator is suggested as the user. With freshly installed software, the password **admin** is assigned to the administrator.

The password validity period is displayed in the last line of the mask.

If it is reached or exceeded, the user will be prompted to change the password.

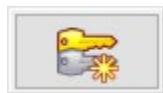

This can also be initiated by clicking the button



The login is completed by the button when the password is correct. In the event of an error, the login can be repeated. After a defined number of failed attempts, the software is terminated.

Change the password:

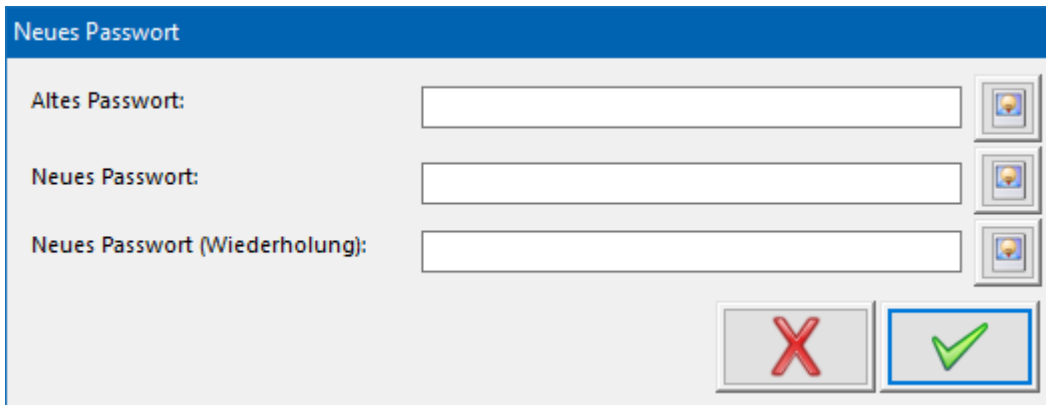

The screenshot shows a web form titled "Neues Passwort" (New Password). It contains three input fields: "Altes Passwort:" (Old Password), "Neues Passwort:" (New Password), and "Neues Passwort (Wiederholung):" (New Password (Repetition)). Each field has a small icon to its right. At the bottom right, there are two buttons: a red "X" button and a green checkmark button.

To change it, the current password is required to be entered first. The new password is entered with repetition. When entering, only * are displayed for each character.

The entered text can be displayed by the button . Point the mouse at the area and hold down the left mouse button.

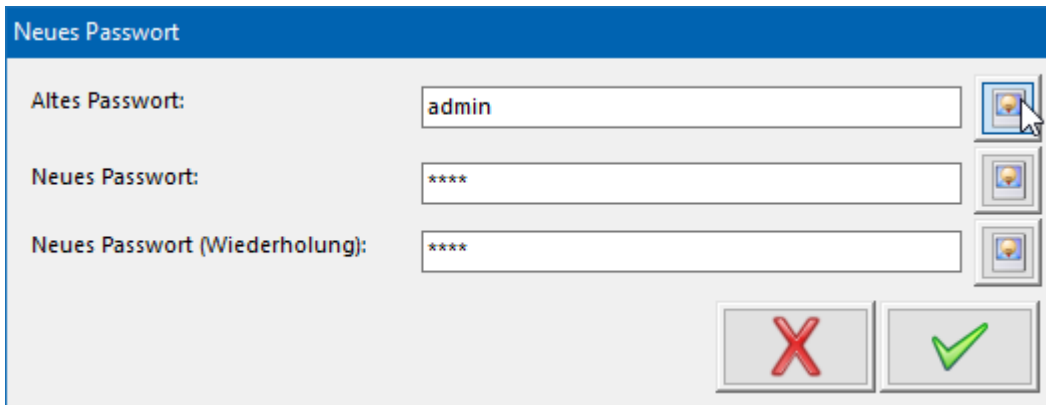

The screenshot shows the same "Neues Passwort" form. The "Altes Passwort:" field now contains the text "admin". The "Neues Passwort:" and "Neues Passwort (Wiederholung):" fields contain four asterisks "****". The eye icons are still present, and the red "X" and green checkmark buttons are at the bottom right.



completes the change,



rejects the change.

4.2 Configuring the "Ser[LOG] function"



Use the button  to start the configuration tool of the Ser[LOG]-Commander.

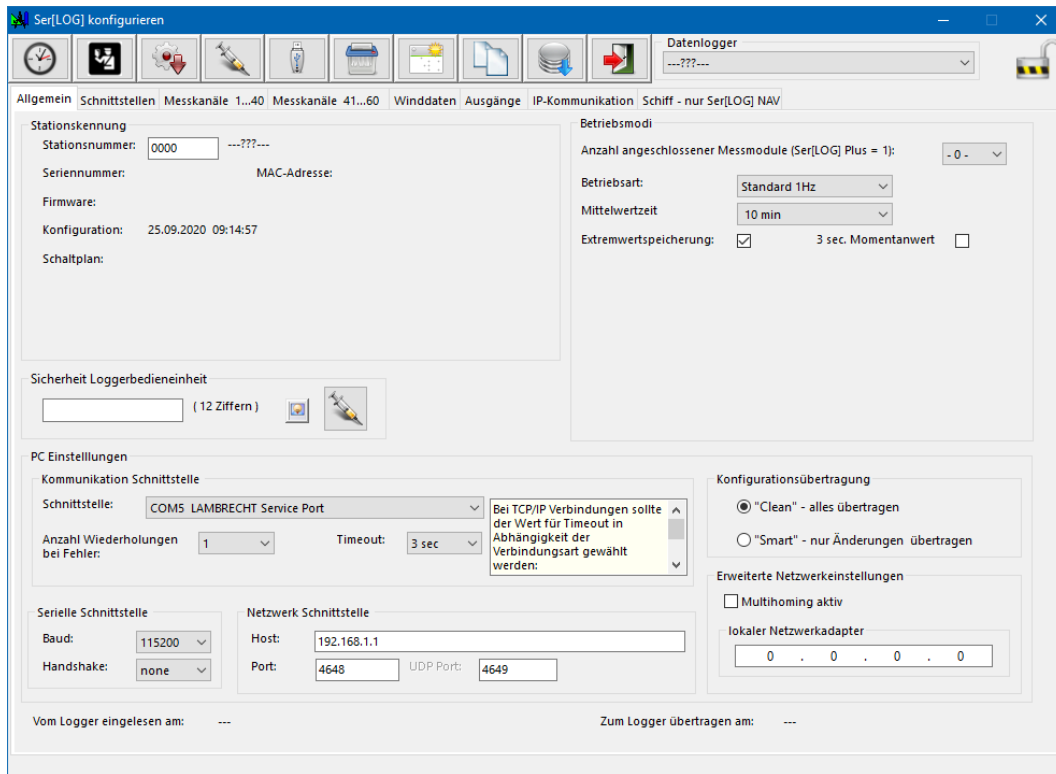

Apart from some special functions, the complete configuration of the Ser[LOG] takes place via this tool.

Tab	Function	Additional Information
General	Configuration of the station identifier, number of used AnDiMod (measurement modules) as well as the PC-side parameters for communication with the Ser[LOG].	
Interfaces	Configuration of the COM interfaces, Ethernet interfaces and data retrieval intervals of the bus-based protocols Modbus RTU, Modbus TCP and SDI-12.	
Meas. channels 1...40 and Meas. channels 41...60	Assigning the connected sensors and measured values to the measurement channels as well as detailed settings for each channel.	
Wind data	Up to 2 pairs of wind sensors can be defined for which the moving average value is calculated.	The data calculated here can be visualized with the LAMBRECHT MeteoWare-CS4 software.
Outputs	Configuration of up to 10 switching channels and actuators for "process control", "error monitoring" or "range monitoring" (alarms).	
IP communication	Configuration of IP-based functions for NTP, FTP, Email, and MQTT via Ethernet or mobile communication, HTTP(S) post via Ethernet, and SMS (alarm) sending via modem.	Among other things, the information content of export files (FTP, e-mail, MQTT and HTTP(S) Post) is specified.

Write protection for station configuration



To prevent a configuration from being changed unintentionally, write protection can be activated via the lock symbol. If write protection is activated, the configuration of the selected station can be read, but no changes are possible. The write protection is indicated by the symbol of the closed lock.

Function of the buttons



Setting the real-time clock

Opens a window for setting the real time clock in the server[LOG]. Only works if the PC communication parameters have been set correctly beforehand.



Query Logger ID

If you are using more than one Ser[LOG], you can use the function "Logger ID query" to query the name and station number of the connected device. Then only one Ser[LOG] may be attached to the interface. Only works if the PC communication parameters have been set correctly beforehand.



If the "Station number" of the Ser[LOG] is known, the configuration of the device can be loaded onto the PC with this function. If the station number is unknown, select the station "---?? ---"off. This definition has the "universal" station number "0000". With this setting, you can retrieve all stations independently of the station number. Only works if the PC communication parameters have been set correctly beforehand.



Get configuration from the logger

Sends the current configuration loaded in the display to the Ser[LOG]. The function prompts you to save the configuration beforehand.



Sends the current configuration loaded in the display and all required files to a USB stick. The function prompts you to save the configuration beforehand. See also chapter..."Config Import via USB stick".



Send configuration to logger

Deletes the configuration currently loaded in the display.



Write configuration to USB stick

Creates a new configuration. The Ser[LOG]-Commander then switches to an "empty" configuration window.



Delete data record

Pressing the button "Copy data set" opens a window in which the station to be copied can be selected and a new name for the station can be assigned.



New record

Saves the current configuration loaded in the display.



Exits the configuration tool and closes the window.

4.3 Function „Tools“

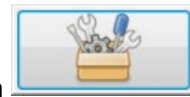

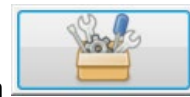
The Ser[LOG]-Commander provides additional tools via the button . This collection provides the following tools for the selected Ser[LOG]. The functions can be carried out via all interfaces that support SNAP or via the network.

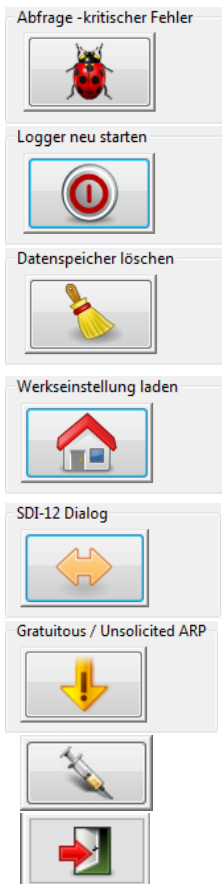

A check is made to see whether Ser[LOG] contains a critical error that impairs normal functioning.

Ser[LOG] reboots, testing all hardware components.

The internal data memory of Ser[LOG] is deleted. This is advantageous if too much simulation data has been collected during maintenance.

The internal configuration of the Ser[LOG] is deleted and set to the factory default. If there is a nonsensical configuration (faulty sensor declarations) in the Ser[LOG] that interferes with normal operation, this function can be used to bring Ser[LOG] back under control.

The SDI-12 dialog allows sending SDI-12 commands directly to the connected sensors.

If a Ser[LOG] is installed in a complex network, or is replaced, sending a gratuitous / unsolicited ARP helps to log the logger to all switches, gateways and routers with its old IP address and its new MAC address.

To update the Ser[LOG] firmware. The function can be accessed via the "Firmware Update" tab.

Exit function. Exits the tool and closes the window.

4.4 Function „Display instantaneous values“



The button  takes you to the tabular display of the current measured values and the moving wind data from the Ser[LOG]. (The wind data display requires the definition of wind pairs in the Ser[LOG] configuration, see chapter configuration).



Starts the instantaneous value polling "Standard".

The scaled instantaneous values of all configured channels are displayed.

Starts the raw value display

The raw value display shows the electrical measured values of the analog channels, not the scaled values.

Calls the data for a network connection via UDP

The information content corresponds to the "standard format". UDP is only possible via network / Ethernet

Stops data retrieval

Exit function

Exits the tool and closes the window.

4.5 Function “Retrieve measured values“



Click the  button to open the window for exporting the saved mean values to a CSV file. The used field separators and the decimal characters that are used can be set under "Other functions - CSV settings".



Starts the call of the selected call period



Exit function. Exits the tool and closes the window.

4.6 Function “Display measurement data“



By clicking the  button you get to a simple tabular display of the stored mean values from an exported CSV file.



Opens a Windows file dialog for selecting the CSV file whose data is to be displayed.



Exit function. Exits the tool and closes the window.

4.7 Function “Graphical display of measured values”

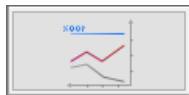

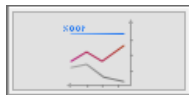
The button  takes you to a graphical display of the saved average values from an exported CSV file.



Opens a Windows file dialog to select the CSV file whose data will then be displayed.

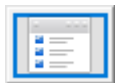

Opens the measured value selection for the graphic



Goes back one day



Goes on one day



Turns on the vertical zoom



Shows a reading ruler on the graphic



Exit function. Exits the tool and closes the window.

4.8 Function "Sensor definition"



By pressing the button  you open the window for defining new sensors. It is possible to create new sensors for the sensor library for all sensor types. (Sensor definitions can be created for analogue, digital (counter or frequency or status), serial, SDI-12, Modbus and virtual sensors.

Important note: Be careful when configuring new sensors. The approach to ensure the greatest possible flexibility in configuration also makes it possible to create "nonsensical" sensor configurations that could interfere with the operation of the Ser[LOG]. It is therefore recommended to work with the predefined sensors or to derive new sensors from existing sensors!



Deletes the currently open sensor. Factory defined sensors cannot be deleted.

Opens a new "empty" data entry for the creation of a new sensor.

Copies the currently opened sensor definition and displays a window for assigning a new name for the sensor.

Saves the currently opened sensor. Changes in factory defined sensors cannot be saved.

Exit function. Exits the tool and closes the window.

4.9 Function "Actuator definition"



Click on the  button to open the window for defining new actuators (Modbus relays).

Actuators (Modbus relays) are considered as single channels like Modbus sensors and not as Modbus devices. For each relay, a separate definition is created to allow Ser[LOG] to control external relays.

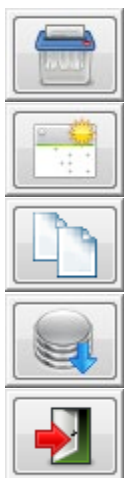

Deletes the currently open actuator. Factory defined actuators cannot be deleted.

Opens a new "empty" data input for the creation of a new actuator.

Copies the currently opened actuator definition and displays a window for assigning a new name to the actuator.

Saves the currently opened actuator. Changes in factory defined actuators cannot be saved.

Exit function. Exits the tool and closes the window.

4.10 Other functions



By pressing the button  you open a menu, which can be used to access other rarely used functions.

Read USB stick	Reads an existing configuration from the USB stick and automatically adds it to the station database if it does not already exist. At the same time, measured values stored on the USB stick are read out and saved in a CSV file.
Security settings	Function for setting up and managing access protection to the Commander and loggers.
CSV settings	Function for setting the date format, decimal points and field separators for formatting the saved measured values.
Export station data	Export one or more station configurations.
Import station data	Import one or more station configurations.
Sensor selection 'My Sensors only'	Pre-selection of sensors to be used for logger configuration. Improves the overview when configuring.
Export sensor data	Export one or more sensor configurations.
Import sensor data	Import one or more sensor configurations.
Reorganize database	Rebuilding and summarizing the data files (station, sensor, relay)
View PDF document	Simple PDF viewer for reading connection diagrams or this manual, for example.
Display status codes	Display of the status codes that were transferred with the read-out measured values.
Language	Change the language (currently German and English are available). After the selection, the Ser[LOG]-Commander is closed and must be restarted.

5 Commissioning / basic configuration

5.1 Connecting sensors

Connect the sensors to the Ser[LOG] according to chapter 2 (wiring - device connection) and according to the used signals.

Make a note of the inputs to which the sensors have been connected. We recommend that you use the tables in Appendix 17. The information entered in the tables will later simplify the configuration of the Ser[LOG] with the Ser[LOG]-Commander.

5.2 Connecting to the supply voltage

After the sensors have been connected, connect them to the supply voltage.

Note: Please note that the Ser[LOG] must be supplied with 10...30 VDC and that this supply voltage is transmitted via the Ser[LOG]-Bus to the "SENSOR SUPPLY" terminals of the AnDiMod.

Note: If the connected sensors are supplied via the "SENSOR SUPPLY" terminals, then all sensors together must not consume more than 500mA. A higher current consumption puts too much strain on the Ser[LOG]-Bus and can lead to damage!

5.3 Configuration of the Ser[LOG]

Ser[LOG] and Ser[LOG]Plus are put into operation, configured, and tested with the configuration tool "Ser[LOG]-Commander".

Ser[LOG]_Commander is a 32 bit Windows application that can be used under the operating systems Windows XP to Windows 10. The application can be used from a USB memory stick. Installation on the PC is not necessary.

If you want to copy the Ser[LOG]-Commander to a USB stick or a PC, all files contained in the PRG_SERLOG folder must be copied as well. The files must always be in the same shared directory.

5.3.1 Basic Station Configuration

Start the Ser[LOG]-Commander by calling the "SerLog_Cmd. exe".



Press the button "Configure Logger" to open the Ser[LOG] configuration window.

The available serial interfaces are deactivated at delivery, therefore the Ser[LOG] can only be reached via:

- Mini-USB service interface or
- USB Bluetooth stick (CSR chipset required)

Both interfaces operate independently of the set baud rate.

5.3.1.1 Configuration via Mini-USB Service Interface

Connect the Ser[LOG] to the PC via the supplied USB-to-Mini USB cable. The Ser[LOG] is not powered via the USB interface. If it is not already done, connect the Ser[LOG] to a suitable power supply (10... 30 VDC).

The driver software for the USB service interface is part of the Windows operating system. Under a freshly installed Windows 10 the interface is recognized as "USB serial device". Windows driver updates can load a "driver" from the company "ELMO" and the interface is then called "ELMO GMAS". To uniquely identify the USB interface as Lambrecht service port, please update the driver for this interface via the device manager by "updating" the driver. Depending on your operating system please load the 32- or the 64-bit version from the directory

Ser[LOG]_Cmd\Ser[LOG]_SYNMET_USB_Driver

After this update the interface is recognized as "LAMBRECHT Service Port".

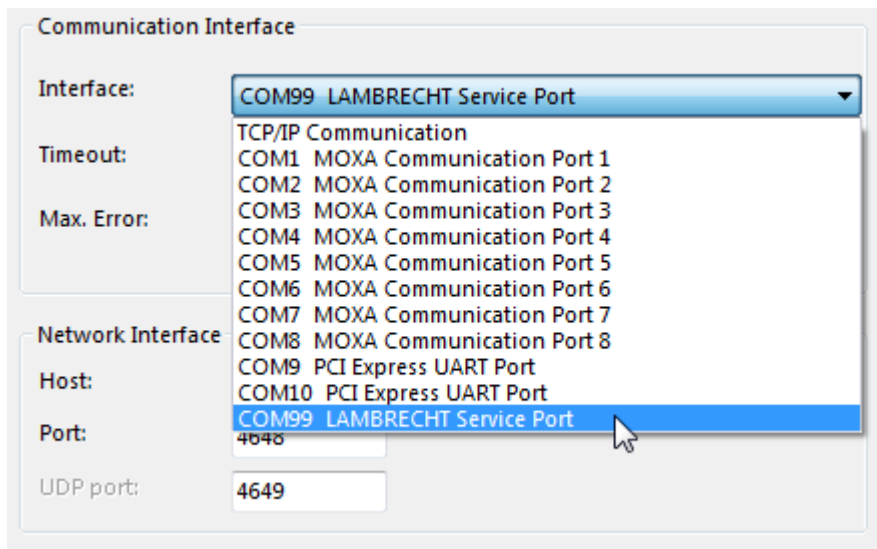

Select the "LAMBRECHT Service Port".

5.3.1.2 Configuration via USB Bluetooth stick

Note: At present, the Ser[LOG] only supports Bluetooth sticks with a Bluetooth chip from CSR.

Plug a suitable Bluetooth stick into the USB-HOST connector of the Ser[LOG] and activate the Bluetooth connection by navigating to the menu item "Bluetooth ON" and pressing the rotary pushbutton.

For the connection, the Bluetooth interface must be activated on the PC and the Ser[LOG], which reports with its station name, must be connected to the PC. The PC asks for the identification of the device to be connected. The identification code is "0000".

After successful coupling, two serial COM interfaces are available on the PC, one "incoming" and one "outgoing" (see Bluetooth settings "COM ports"). In the Ser[LOG]-Commander select the COM port of the "Outgoing" COM interface in the "Interface" selection box of the "PC Settings".

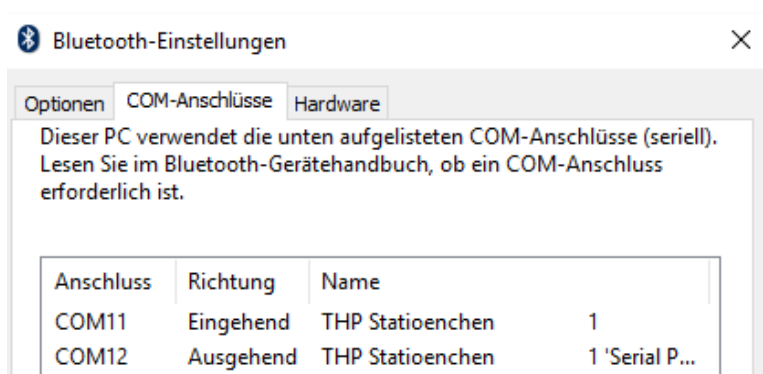

5.3.1.3 Create new configuration

To configure the Ser[LOG], the station number of the logger must be known. In the factory setting, each Ser[LOG] has the station number: 0001.

At the beginning of the configuration, it is recommended to load the current configuration from the data logger first. This allows simultaneous testing of the communication with the Ser[LOG] to determine whether communication with the Ser[LOG] is working.

To do this, select the station with the designation "---?? ---" off. This definition has the "universal" station number "0000". With this setting you can retrieve all stations, no matter with which station number they are configured.



The configuration of the device can be loaded into the Ser[LOG]-Commander with the function "Call up configuration of logger".

If a station with the same name already exists, the Ser[LOG]-Commander asks whether this station should be overwritten. An existing configuration can only be overwritten if no write protection is set and it is not a "factory definition". If the station does not yet exist, it is automatically saved.



If the station or data logger is to be called, a copy of the corresponding data record must be made. Pressing the button "Copy data set" opens a window in which the station to be copied can be selected. In the field (after:) underneath the station list, the new name can be assigned to the station. The copying process is completed by pressing the button.



To create a completely new configuration, activate the "New record" function. The Ser[LOG]-Commander then switches to an "empty" configuration window. In this mode, the "Data Logger" selection box is an input field in which you can enter the name of your station or Ser[LOG]. In the field "Station number" enter the number under which the device should be accessible.

Note: If a network is operated with several Ser[LOG], the station number must be unique. It is the key with which the logger is addressed.



By pressing the button "Save data set" the new station is created and saved in the Ser[LOG]-Commander. After the station has been saved, the Ser[LOG]-Commander returns to the normal configuration window and the field "Data logger" becomes a selection field again.

5.3.2 Activating AnDiMod Extension Modules

If AnDiMod modules are connected to the Ser[LOG], they must be activated with the Ser[LOG]-Commander!

The number of measuring modules can be set in the frame "Analog Measuring Modules". With a Ser[LOG], the number of measurement modules is set to "0". With a Ser[LOG]Plus, an AnDiMod measurement module is already integrated in the housing. Therefore, check whether the number of measurement modules in the Ser[LOG]Plus is set to "1".

Note: When creating a new data set, the number of measuring modules is initially set to "0".

The setting of the number of measurement modules used has a considerable influence on the following configuration options of the measurement channels.

Note: If AnDiMod modules have been activated in the Ser[LOG]-Commander but are actually not connected, this leads to a critical system error when the Ser[LOG] system is switched on.

5.3.3 Setting the measured value acquisition

In the "Operating modes" frame, you can define the time for averaging. The averaging time is also the storage interval in which the Ser[LOG] saves the measured values. By default, the averaging time is set to "10 min". Values between 1 minute and 60 minutes can be set. To ensure the best compatibility for further processing programs, it is recommended to set the time interval to 1 minute or to 10 minutes. The storage always takes place at the full minute interval after the set local time.

Currently, only the standard measuring interval in 1 Hz cycle or 2 Hz cycle is available for selection as operating mode.

In addition to the average values, the extreme values, i.e. the minimum and maximum values of the respective interval can be saved. If extreme values are to be saved, please activate the "Extreme value storage" field.

5.3.3.1 **Setting instantaneous values as 3-second moving averages**

For some applications (e.g. ICAO) the instantaneous values must be displayed as 3-second moving averages. If the function "3 sec. Instantaneous value" is activated in the frame "Operating modes", then the 3-second moving average is formed directly in the Ser[LOG] and can be sent for display directly to further processing programs like e.g. the LAMBRECHT MeteoWare CS-4. The setting has no influence on the storage of the mean values.

5.3.4 **Interface configuration for measured value retrieval and remote configuration**

If the configuration of the Ser[LOG] or the retrieval of the measured values for later use is to be carried out remotely or via a network, the following communication paths are available:

- Network / Internet (TCP/IP)
- Serial interface RS232 / RS485 / RS422

5.3.4.1 **Communication via network / Internet (TCP/IP)**

In the "Network interface" frame, the IP address, or the host name under which the Ser[LOG] can be reached is entered in the "Host:" field. In the default setting, the Ser[LOG] can be reached via the IP address 192.168.1.1. The "Port" field contains the number of the port on which communication is expected at the data logger (default value: 4648). The port used for fast data transfer via UDP is entered in the "UDP Port" field.

The value in the "Timeout" selection field determines how many seconds the data logger waits for a response. Depending on the connection type, the timeout time should be adjusted.

LAN:	same as for serial connection (standard 3 sec.)
Internet:	min. 20 sec.
GPRS:	min. 45 sec.

The number of communication repetitions before the communication is finally terminated when errors have occurred is set in the "Number of repetitions on error" selection list. The default value of 5 should be set high for connections that are very susceptible to errors.

Note: Please note that a too short timeout time with a too small number of repetitions may lead to connection failures, e.g. in the instantaneous value display of further processing programs such as the LAMBRECHT MeteoWare CS-4. On the other hand, too large timeout times and too many repetitions lead to long waiting times in the event of connection errors, e.g. when retrieving the configuration, during which time the Ser[LOG] Commander cannot be operated, for example!

In the "Advanced network settings" frame, for PC systems with multiple Ethernet adapters / WLAN adapters, the IP address can be selected via which the cable connection to Ser[LOG] is established. This setting bypasses the automatic adapter selection in the Windows operating system and reduces the number of potential errors. The adapter selection is switched on by activating the "Multihoming".

Changing the network settings of the Ser[LOG]

To change the network settings of the Ser[LOG], switch to the "Interfaces" tab of the configuration window.

Activate the Ethernet interfaces in the "Network settings" frame via the check box "Ethernet Power ON".

The Ser[LOG] does not have a setting to support a DHCP server, therefore a fixed IP address must be assigned. In this box, also enter the Sub Net Mask and the Gateway.

In the field "SNAP Port" the address of the port used for communication via SNAP on the network interface is entered. The default port for SNAP communication is 4648.

The setting "UDP port" is intended for fast data transfer via UDP. See also chapter 5.4.3. The default port for data transmission is 4649.

It is possible to retrieve the current values of the Ser[LOG] in tabular form via the network interface via HTTP. For this purpose, a corresponding port must be entered in the field "WEB http Port". By default, port 80 is used for this purpose. Port 80 is the official standard port for http communication and therefore does not have to be specified when you call it up in the browser. If the IP address of the Ser[LOG] is called via the browser when the function is activated, a simple table with the measured instantaneous values is displayed. The function is limited to one user. Multiple parallel calls of the current value page are not possible.

Make a note of the network settings for later communication.

5.3.4.2 Communication via serial interface RS232 / RS485 / RS422

In the "Serial interface" frame, the baud rate and handshake for serial communication are set. Communication is via the SNAP protocol. Communication is always carried out with 8 data bits, 1 stop bit and without parity (None). The "Connection type" selection list determines whether communication is carried out via a direct connection (online) or via a dial-up modem connection (modem). For communication via the serial interface, the selection must be set to "Online" (direct connection).

To use the communication via serial interface, the used interface must be activated and set to SNAP protocol. To do this, switch to the "Interfaces" tab of the configuration window and activate the COM interface to be used via the "Power ON" checkbox in the respective frame. It is recommended to use one of the interfaces COM1 to COM4 for communication, as COM5 and COM6 have special functions for connecting SDI-12 sensors or AnDiModules.

Set the SNAP protocol for the selected interface under "Protocols". The communication parameters "Data Bits", "Stop Bits" and "Parity" are automatically set to 8 data bits, 1 stop bit and no parity (None). Do not change these settings!

Note: Please note that communication between the PC and the Ser[LOG] is always carried out via the SNAP protocol with 8 data bits, 1 stop bit and without parity (None).

If necessary, make the settings for "Handshake" and the baud rate (Baud). The settings for handshake and baud rate must match those in the "General" tab of the "Serial Interface" frame.

Note the settings for later communication.

5.3.5 Configuration of the sensors

The Ser[LOG]-Commander offers an extensive library of preconfigured sensors from the LAMBRECHT meteo product portfolio. The sensor library can be extended by the user with own sensors.

The measurement channels are assigned via the "Measurement channels 1...40" and "Measurement channels 41...60" registers. The appearance of the respective registers depends on the number of AnDiMod used. A total of 60 channels can be defined. They differ in analog, digital status and serial/virtual channels. A "sensor" always represents one measured value per measurement channel.

The number of available channels depends on the number of AnDiMod used.

Expansion level	Analog	Digital	Status (status)	Serial / Virtual
Ser[LOG]	0	0	2	58
Ser[LOG]+1AnDiMod = Ser[LOG]Plus	12	3	2	43
Ser[LOG]+2AnDiMod	24	6	2	28
Ser[LOG]+3AnDiMod	36	9	2	13

The designation in the "Channel" column designates the channel number and the connection to the Ser[LOG] or AnDiMod.

S03 - 1 A01 = Kanal S03 belegt durch Analogeingang Klemme 1 von AnDiMod-Modul mit Adresse 1

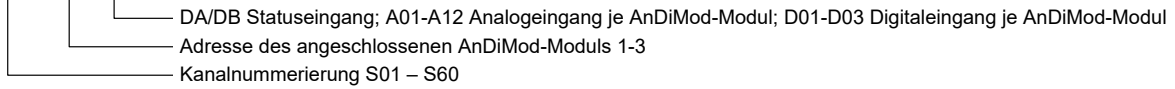

By clicking on a sensor selection field of the respective channel (in the example "Channel S18") the selection of the already defined sensors is displayed.

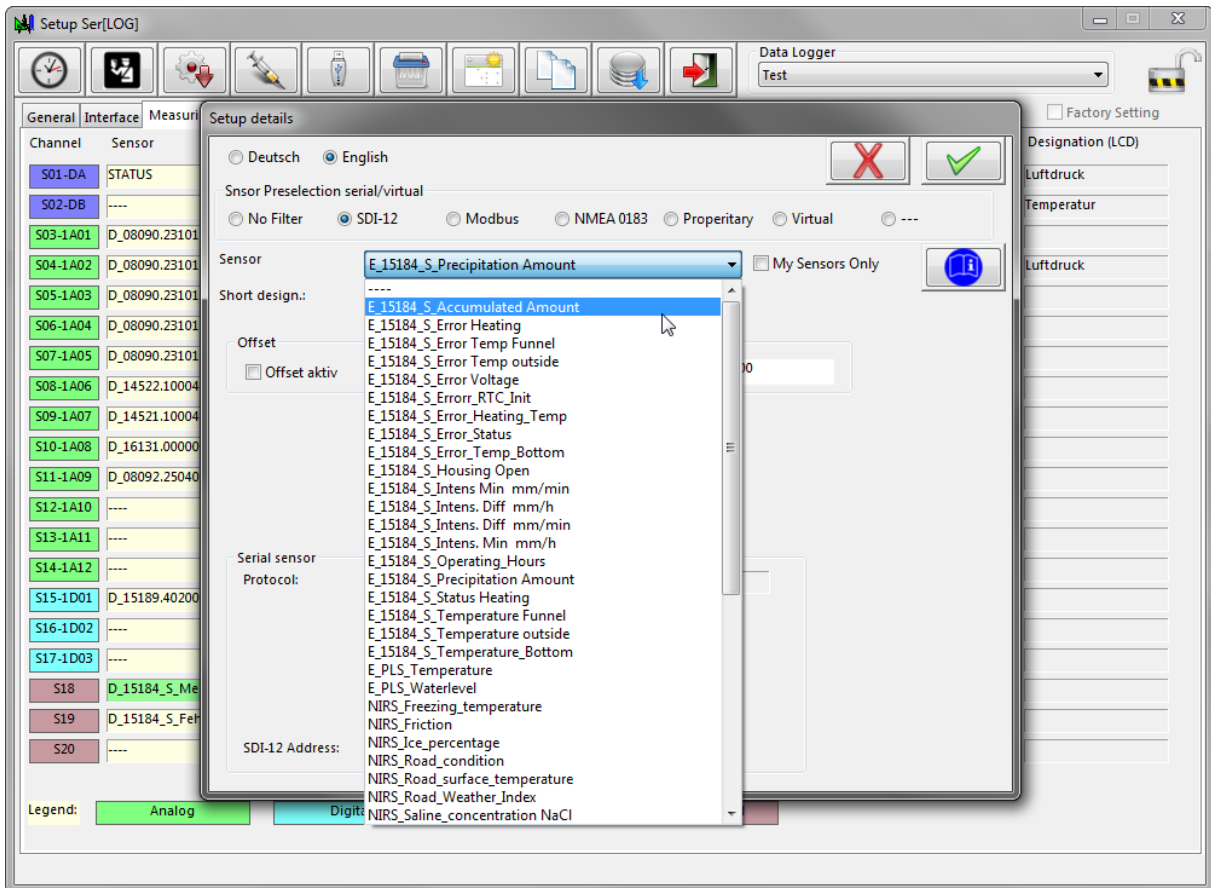

A list of predefined sensors can be found in chapter 14.

Selecting a sensor opens the "Settings Details" window, which will prompt you to enter further parameters if necessary. It can also be called later by button . The structure of the window is context related.

Tip: A channel can be deleted by double-clicking on its position (column channel).

All sensors have the same feature in common, i. e. the possibility to change the sensor abbreviation. This abbreviation is the text displayed on the display of the Ser[LOG] which is later used in the advanced software.

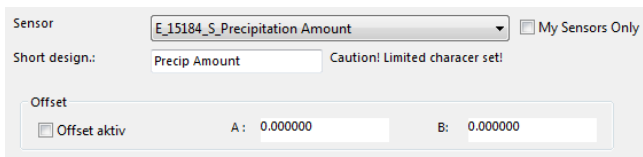

It is also possible to enter a linear correction for each sensor according to the formula $Y=A*X+B$, where X is the measured value and Y is the corrected value. The Y-value is processed further in each case.



The button  displays a PDF document assigned to the sensor, e. g. the corresponding wiring diagram.

5.3.5.1 Configuration Global Radiation Sensors

Sensor: E_16130.000000_Radiation My Sensors Only
Short design.: Radiation Caution! Limited character set!
Offset
 Offset aktiv A: 0.000000 B: 0.000000
Radiation sensor individual EMK
11.3657

If global radiation sensors are configured, it is necessary to enter the individual EMK for these sensors in the "Settings Details" window. This value represents the signal sensitivity and is usually given in $\mu\text{V}/(\text{W}/\text{m}^2)$ in the documentation of the global radiation sensors.

5.3.5.2 Configuration of a pair of vectorially linked wind sensors

If wind speed and wind direction are to be calculated vectorially to the mean value, the wind sensors must be defined as wind pairs.

To do this, first create a wind speed sensor without a vector partner.

Sensor: E_14522.100040_WS_Pro_4-20_75m/s My Sensors Only
Short design.: Wind Speed Caution! Limited character set!
Offset
 Offset aktiv A: 0.000000 B: 0.000000
Wind sensor vector partner
S09 E_14521.100040_WD_Prof_4-20mA

Then create a wind direction sensor and link it to the previously created wind speed sensor in the "Vector partner wind sensors" selection box in the "Settings Details" window.

Now open the "Settings Details" window of the channel with the wind speed sensor and connect it to the corresponding wind direction sensor.

If no vector partner is selected in each case, the calculation of the mean value for the wind direction is still vectorial, whereby a wind speed of constant 1 m/s is calculated. In this case, the mean value of the wind speed is calculated scalar.

5.3.5.3 Configuration serial sensors

The configuration of the serial sensors takes place in 3 steps:

1. First of all, the Ser[LOG] must be informed about the interfaces to which the sensors are connected, and which protocol is used by the sensors.
2. For sensors with SDI-12, Modbus RTU or Modbus TCP, the time interval at which the Ser[LOG] should retrieve the data from the sensor must be set.
3. Afterwards, the transmitted parameters/measured values must be assigned to the internal measurement channels.

5.3.5.3.1 Configuration of the serial interface for sensors

For the sensor assignment of the interfaces, please open the register selection "Interfaces" of the configuration window.

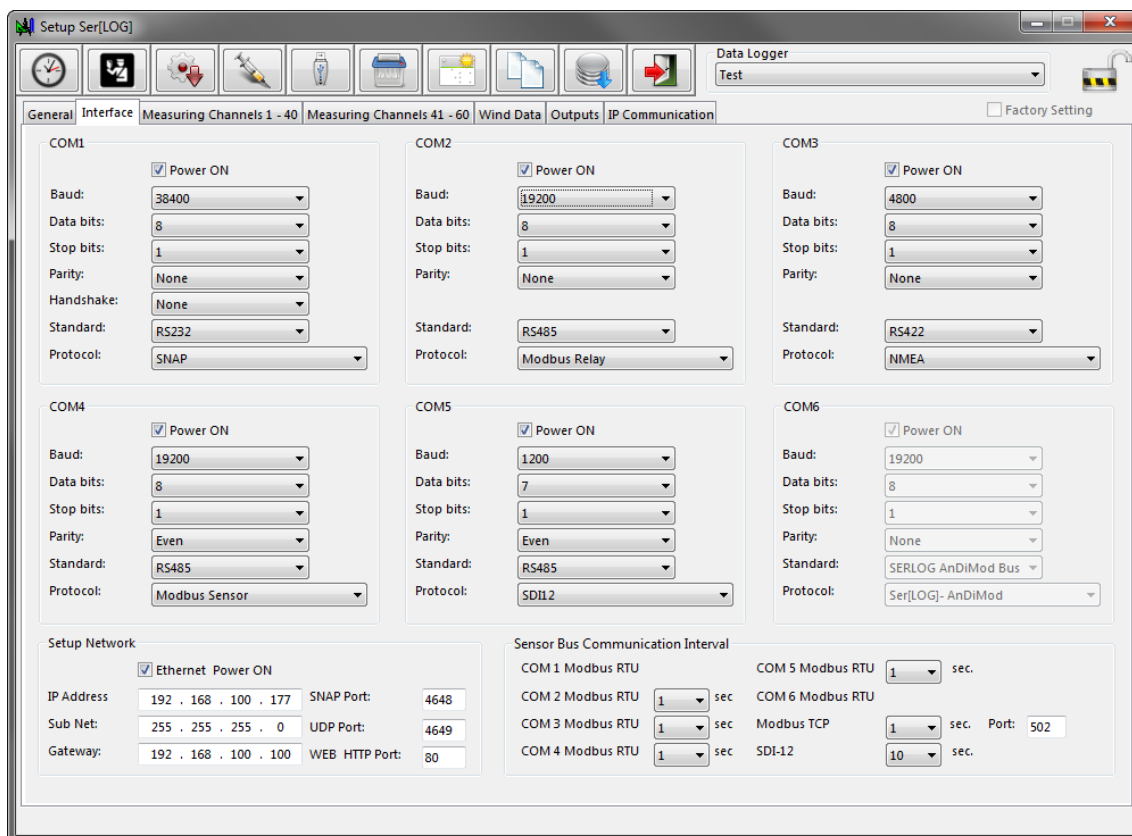

The following interfaces and protocols are supported:

Interfaces

- RS 232
- RS 485*
- RS 422*

Protocols

- NMEA
- Modbus Sensor
- SDI-12 (only per COM5)
- RPT350
- PTB330 / PTB320
- X81
- LDWHM_12
- LD-40
- CL31 msg 2_base
- FS11
- VFP 730 'compressed format'
- rain[e] 'SDI-12 on RS485'
- 15189 'SDI-12 on RS485'
- rain[e] DWD Polling
- Pluvio 1 DWD
- Pluvio 2 M-Command
- LPM Distrometer Telegram 6
- HMP 155
- ADAM-4051
- Sea_Bird SBE-37SIP
- IceSight 5433
- HM Voltmeter

* Please note that for RS422 and RS485, the corresponding jumpers must also be set in the jumper field. See chapter 14.

For more information about the supported protocols, see chapter "Protocols".

The assignment of the available interface standards is made according to the hardware description in chapter 1.1 and the connection description in chapter 0.

In general, it is sufficient to activate the respective interface via the check box "Power ON" and then select the protocol used and finally, if necessary, the required interface standard. In most cases, the remaining communication settings are made automatically. Nevertheless, please check the communication parameters Baud rate (Baud), "Data Bits", "Stop Bits", "Parity" and "Handshake" and adjust them if necessary.

5.3.5.3.2 Setting the data retrieval interval for SDI-12, Modbus RTU and Modbus TCP sensors

The measured values of sensors with SDI-12, Modbus RTU or Modbus TCP are not transmitted automatically, but must be called up by the Ser[LOG]. For this purpose, the respective call-off interval must

be set in the register selection "Interfaces" of the configuration window in the frame "Bus - Data retrieval - Intervals" for SDI-12, Modbus-TCP or Modbus-RTU for each COM interface.

Sensor Bus Communication Interval

COM 1 Modbus RTU	1	sec.	COM 5 Modbus RTU	1	sec.	
COM 2 Modbus RTU	1	sec.	COM 6 Modbus RTU			
COM 3 Modbus RTU	1	sec.	Modbus TCP	1	sec.	Port: 502
COM 4 Modbus RTU	1	sec.	SDI-12	10	sec.	

5.3.5.3.3 Assignment of serial sensors to the measurement channels

The lists of available serial sensors can be found in this manual.

Selecting a serial sensor opens the "Settings Details" window, which prompts you to specify further parameters.

For serial sensors, the COM port to which the sensor is connected must be selected.

Serial sensor

Protocol: X81

Serial port: COM2 | X81

5.3.5.3.4 Assignment of SDI-12 sensors to the measurement channels

For SDI-12 sensors, the address of the respective sensor must be specified.

Note: SDI-12 sensors often supply several parameters. For the Ser[LOG], each parameter must be treated as a single sensor.

Serial sensor

Protocol: SDI12

SDI-12 Address: 0

5.3.5.3.5 Assignment of Modbus RTU sensors to the measurement channels

For Modbus RTU sensors, the COM port to which the sensor is connected must first be selected. The address of the sensor on the bus must then be set via the "Modbus RTU address" selection field.

Note: Modbus sensors often supply several parameters. For the Ser[LOG], each parameter must be treated as a single sensor.

Note: The Modbus register containing the respective value is specified in the respective sensor definition.

Serial sensor

Protocol: Modbus Sensor

Serial port: COM4 | Modbus Sensor

Modbus RTU Address: 1

5.3.5.3.6 Assignment of Modbus TCP sensors to the measurement channels

For Modbus TCP sensors, select "Modbus TCP" for the "interface". The IP address of the sensor in the network must then be set in the "Modbus TCP address" input field. The port used is entered in the "Modbus Port" input field.

The "Modbus RTU Address" selection box is ignored.

Note: Modbus sensors often supply several parameters. For the Ser[LOG], each parameter must be treated as a single sensor.

Note: The Modbus register in which the respective value is located is specified in the respective sensor definition.

Serial sensor

Protocol: Modbus Sensor

Serial port: Modbus TCP

Modbus TCP IP: 192 . 168 . 100 . 103

Modbus TCP Port: 502

Modbus RTU Address: 2

5.3.5.3.7 Assignment of virtual sensors to the measurement channels

When selecting virtual sensors, the window "Definition of virtual sensors" is opened, in which the parameters for calculating the respective value are defined.

Deutsch English

Snsor Preselection serial/virtual

No Filter SDI-12 Modbus NMEA 0183 Propertitary Virtual ---

Sensor: E_Dewpoint (Temp_Humidity) My Sensors Only

Short design.: Dewpoint Caution! Limited characer set!

Designation: Dewpoint by Temp and Humidity

Unit: Deg C Caution! Limited characer set!

Decimal places: 1

Sensor type: Dewpoint

Processing: Average scalar

Formula data

Dry bulb temp.: S03 E_08090.231010_Temperature PT100

Relative humidity: S11 E_08092.250402_Humidity 0-1V

A list of available virtual sensors can be found in chapter 14.4.6 and chapter 14.4.7.

5.3.5.4 Configuration of sensors with look-up table

A look-up table can be stored for sensors with a special signal characteristic curve. See also section 5.3.6.5 "Creating new sensors".

Setup details
 Deutsch English
 Snsor Preselection serial/virtual
 Sensor: D_Equitensimeter My Sensors Only
 Short design.: BodenF Caution! Limited character set!
 Signal: Value: Look Up Table: 1

1	0.000000	0.000000
2	1.000000	14.000000
3	2.000000	22.000000
4	3.000000	25.000000
5	4.000000	27.000000
6	5.000000	28.000000
7	6.000000	29.000000
8	7.000000	32.000000
9	8.000000	37.000000
10	9.000000	44.000000
11	10.000000	54.000000
12	11.000000	65.000000
13	12.000000	71.000000
14	13.000000	75.000000
15	14.000000	80.000000

In the look-up table, markers of the signal characteristic curve can be entered between which linear interpolation is performed. The order in which the sampling points are entered is arbitrary. If the window is closed via the "OK" button (green token), the table is automatically sorted and saved.

Note: If you want to delete a marker, simply double-click on the number field (1-15) of the respective line.

Example:

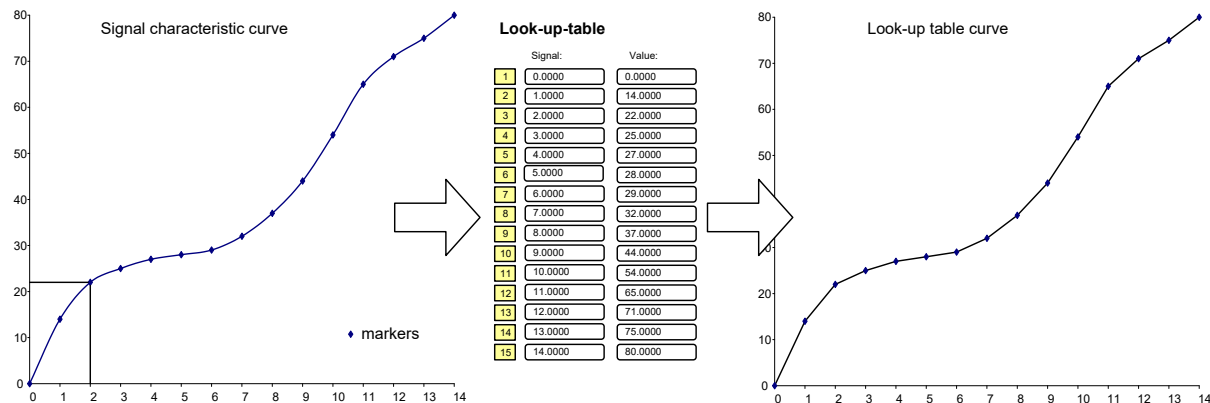

5.3.5.5 Creating new sensors

If you use sensors that are not included in the predefined sensors, you can create your own new sensors. New sensors can be defined for:

Serial

- SDI-12
- Modbus RTU
- Modbus TCP
- NMEA
A list of supported NMEA datasets can be found in chapter 13.1.

Digital and status

- Status
- Impulse
- Frequency
As switch (relay, reed), open collector (OC) or logic signal (0/1) from 0...30V

Analogue signals

- 5 V bipolar,
- 5 V unipolar,
- 50 mV bipolar,
- 0/4...20 mA,
- 500 Ohm and
- 5000 Ohm.

To create new sensors, first close the configuration window.



Click on the "Define sensors" button in the main selection to open the "Define sensors" window.

Important note: Be careful when configuring new sensors. Due to the approach of ensuring the greatest possible flexibility in configuration, it is also possible to create "nonsensical" sensor configurations that could interfere with the operation of the Ser[LOG]. It is therefore recommended to work with the predefined sensors if possible or to derive new sensors from existing sensors!

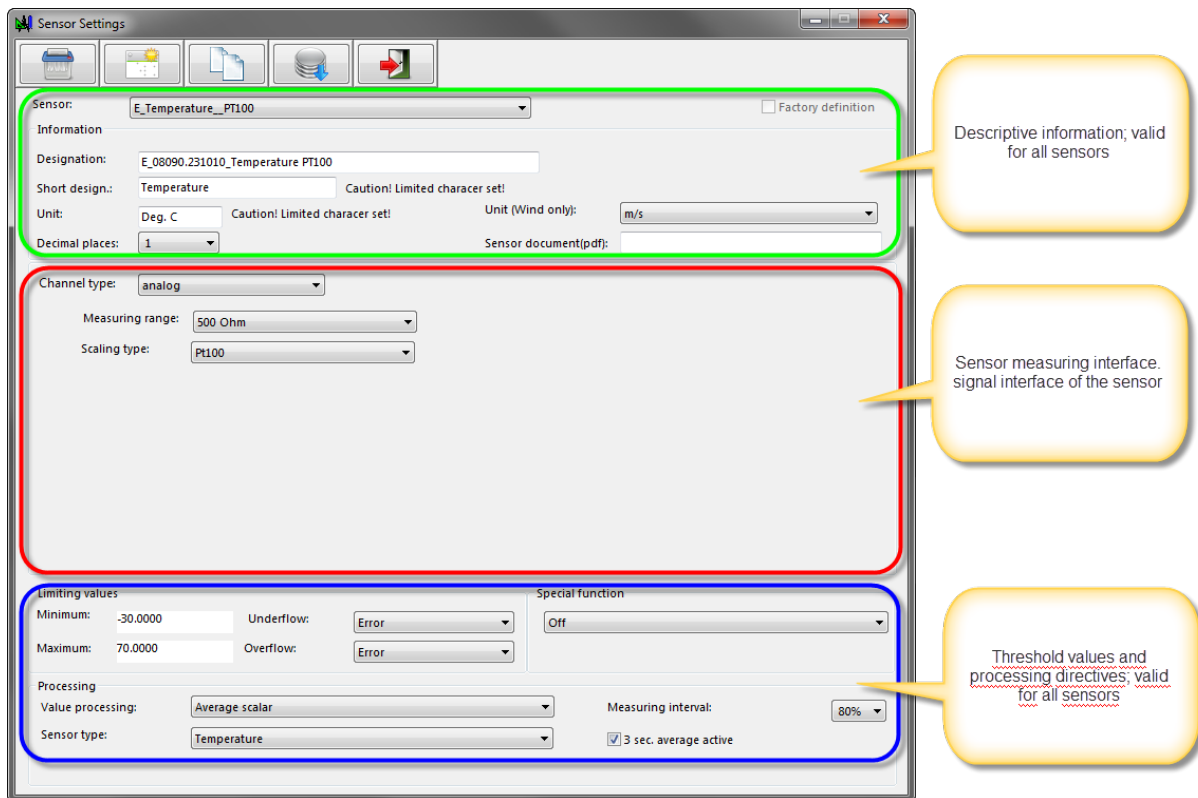

To create a new sensor, click on the "New Data Set" button. The Ser[LOG]-Commander then switches to a "new" definition window. In this mode, the selection field "Sensor" is an input field in which you can enter the name of the sensor.

You then define the general sensor information. In the field "Name" you can enter a descriptive text for the sensor. The "Abbreviation" is the text that appears on the display of the data logger and is used by the LAMBRECHT programs "MeteoWare_CS" or "MeteoWare_Net_Center". Only a restricted character set (ASCII) is available for this field. A table with the permitted characters can be found in Chapter 18.

Enter the unit of the sensor in the "Unit" field of the same name. The restricted character set also applies here.

If the sensor is a wind speed sensor, please specify in the field "Unit (only wind)" whether the sensor delivers its values in "m/s" or in "kt" (kn). The separate selection of the wind unit is required for downstream programs such as MeteoWare CS-4 to convert the units if necessary.

Please select the number of decimal places with which the measured values are to be displayed in the field "Decimal places".

The minimum and maximum values allowed are defined in the "Limits" section. In the field "Undercut" you can select whether an error is reported if the value falls below the minimum value or whether the measured value is set to the minimum value. Accordingly, you can select in the field "Exceeded" whether an error is reported if the maximum value is exceeded or whether the measured value is set to the maximum value. See also chapter 5.3.6.5.8.

The "Processing" frame defines the routine after which the sensor signal is to be processed. The following routines are available:

Sum	The Ser[LOG] adds up the measured values and stores the sum for each storage interval.
Average value scalar	Standard mean value for most measured values.
Mean value vectorial (wind direction)	Calculation of the vectorial average value for the wind direction. This processing opens the "Settings Details" window for the "Vector linked pair of wind sensors" (chapter 5.3.6.2) when configuring the sensors.
Mean value vectorial (wind speed)	Calculation of the vectorial average value for the wind speed. This processing opens the "Settings Details" window for the "Vector linked pair of wind sensors" (chapter 5.3.6.2) when configuring the sensors.
Last measured value in storage interval	The last measured value supplied by the sensor at the time of storage is stored. If the last value is incorrect, the corresponding error is saved.
Last valid measured value in the storage interval	The last measured value delivered by the sensor at the time of saving is saved. If the value is incorrect, the last valid value is saved.
Maximum of the storage interval	The maximum value of the respective storage interval is stored.
Minimum of the storage interval	The minimum value of the respective storage interval is stored.
Total rainfall without correction	This summation for precipitation quantity sensors with pulse output, (1 pulse = x precipitation quantity). With this function, the Ser[LOG] adds up the measured values and saves the sum for each storage interval. Please also enter the rocker factor (mm per pulse) for this application.
Total rainfall with correction	This summation for precipitation quantity sensors with pulse output, (1 pulse = x precipitation quantity). With this function, the Ser[LOG] adds up the measured values and saves the sum for each storage interval. Please also enter the rocker factor (mm per pulse) for this application. In addition, the Ser[LOG] calculates a frequency-dependent correction of the precipitation quantity. (The correction is only valid for LAMBRECHT precipitation sensors without integrated correction.)
Harmonic mean	Calculates and stores the harmonic mean value of the measured value. The harmonic mean value is automatically set to "0" as soon as a measured value in the storage interval has the value "0".

The processing routines "Variance (...)", "Standard deviation (...)" are only intended for virtual channels.

Variance	Calculates and saves the variance of the measured value.
Standard deviation	Calculates and saves the standard deviation of the measured value.
Standard deviation (wind direction)	Calculates and saves the standard deviation for the wind direction on a vectorial basis of the measured value.
Standard deviation (wind speed)	Calculates and saves the standard deviation for the wind speed on a vectorial basis of the measured value.
Variance (wind direction)	Calculates and saves the variance for the wind direction on a vectorial basis of the measured value.
Variance (wind speed)	Calculates and saves the variance for wind speed on a vectorial basis of the measured value.

The selection box "Sensor type" categorizes the sensors according to the respective measurement type. This information is used by the processing software, e. g. MeteoWare CS-4 on the PC.

Available sensor types are:

"A"	= "A_____"	"N"	= "Precipitation"
"B"	= "Battery data"	"O"	= "O_____"
"C"	= "Cloud height"	"P"	= "Air pressure"
"D"	= "Dew point"	"Q"	= "Present weather"
"E"	= "Evaporation"	"R"	= "Wind direction"
"F"	= "Free scale"	"S"	= "Radiation"
"G"	= "Wind speed"	"T"	= "Temperature"
"H"	= "Humidity"	"U"	= "Voltage"
"I"	= "Current"	"V"	= "Visibility "
"J"	= "Solar data (charging voltage,...)"	"W"	= "Resistance"
"K"	= "K_____"	"X"	= "Leaf wetness"
"L"	= "Frequency"	"Y"	= "Other"
"M"	= "M_____"	"Z"	= "Status"

In the selection field "Minimum valid measured values", the percentage of valid measured values can be set in percent, if an error is saved when the value falls below this limit. By default, a minimum of 80% of valid measured values is required to form an average value.

Via the checkbox "3 sec. Calculation allowed" the sensor can be marked to be used as a 3-second slider if the function "3 sec. Current value" is activated in the station configuration.

The channel type is defined in the middle group. The channel types essentially correspond to the available interfaces:

- Analog
- Digital
- Modbus
- SDI12
- Serial
- Virtual

Depending on the channel type, different configuration options are displayed. The configuration of the respective channel types is described in the following chapters.

5.3.5.5.1 Channel type - Analog

The following measuring ranges can be selected for the analogue measurement:

- 5 V bipolar,
- 5 V unipolar,
- 50 mV bipolar,
- 0/4...20 mA,
- 500 Ohm and
- 5000 Ohm.

Select the required measuring range. If you want to measure a voltage greater than 5 V, apply the voltage via a suitable voltage divider which generates a voltage suitable for Ser[LOG].

Channel type: analog

Measuring range: 5V unipolar

Scaling type: Standard

Signal minimum: 0.000000 Signal maximum: 5.000000

Value minimum: 0.000000 Value maximum: 750.0000

The scaling of the measuring signal is carried out according to the following "scaling modes":

- Standard

Linear scaling according to $y=ax+b$, where "a" and "b" are calculated from the signal minimum, signal maximum, value minimum and value maximum.

- PT100

Can be used for the measuring range 500Ω especially for the use of Pt100 temperature sensors. In this case, a polynomial stored specifically for Pt100 sensors is used for scaling.

- PT1000

Can be used for measuring range 5000Ω especially for the use of Pt1000 temperature sensors. In this case, a polynomial stored specifically for Pt1000 sensors is used for scaling.

- Polynom

Allows the use of a 5th-order polynomial for scaling the selected measuring range.

- Look_Up_Table_1

Scaling with the use of up to 15 calibration points in table 1.

See also chapter 5.3.6.4 Configuration of sensors with look-up table

- Look_Up_Table_2

Scaling with the use of up to 15 calibration points in table 2.

See also chapter 5.3.6.4 Configuration of sensors with look-up table

Example: Sensor type "Polynom"

Channel type: analog

Measuring range: 5V unipolar

Scaling type: Polynomial

Polynomial: 2. Order

Coefficient 0:	2.55	Coefficient 1:	364
Coefficient 2:	1111	Coefficient 3:	0.0000000
Coefficient 4:	0.0000000	Coefficient 5:	0.0000000

5.3.5.5.2 Channel type - Status

For status sensors, the type of signal can be selected in the measurement range selection box. Available for selection:

- Status active = high
- Status active = low

The scaling mode "Standard" can be selected for the status.

Measuring ranges	Scaling mode	Comment
Status active = high	Standard It applies: Signal minimum=0, signal maximum=1, Minimum value at logical-0 is usually the minimum value. 0 and maximum value can be scaled.	It applies: logic 1 (true) at high level, e. g. 5V or switch open logic 0 (wrong) at low level, e. g. 0V or switch closed
Status active = low	Standard It applies: Signal minimum=0, signal maximum=1, Minimum value at logical-0 is usually the minimum value. 0 and maximum value can be scaled.	It applies: logic 1 (true) at low level, e. g. 0V or switch closed logic 0 (wrong) at high level, e. g. 5V or switch open

Select the scaling mode "Standard" for "**Status active=high**" and "**Status active=low**". However, in this case the scaling is usually limited to the scaling of the value maximum (with signal minimum=0, signal maximum=1, value minimum=0 (usually)).

Examples of status sensors

Status 0...100%

The screenshot shows a configuration panel for a status sensor. It includes a dropdown for 'Channel type' set to 'status', a dropdown for 'Measuring range' set to 'Status active=high', and a dropdown for 'Scaling type' set to 'Standard'. Below these are four input fields: 'Signal minimum' (0.00), 'Signal maximum' (1.00), 'Value minimum' (0.00), and 'Value maximum' (100.0000).

The upper figure shows an example of the scaling for a sensor with status output whose measured value is raised to the values 0 or 100. This means that an average value can be displayed for the status in %. A value of 50% then means that the status was 50% of the measurement interval active and 50% inactive.

5.3.5.5.3 Channel type – Digital

For digital sensors, the type of digital signal can be selected in the Measuring range selection box. Available for selection:

- Frequency
- Pulse

For the "Frequency" the scaling modes "Standard" and "Polynomial" can be selected in the same function as for the analogue sensors.

Measuring ranges	Scaling mode	Comment
Frequency	Standard Linear scaling according to $y=ax+b$, where "a" and "b" are calculated from the signal minimum, signal maximum, value minimum and value maximum.	For measuring frequencies up to 10 kHz.
	Polynomial Allows the use of a 5th-order polynomial for scaling the selected measuring range.	
Pulse	Standard It applies: Signal minimum=0, signal maximum=1, value minimum at logical-0 is 0 and value maximum can be scaled.	For sensors with pulse output, such as precipitation gauges.

Select the scaling mode "Standard" for "**Pulse**". However, the scaling in this case is limited to the scaling of the value maximum (with signal minimum=0, signal maximum=1, value minimum=0 (usually)).

Examples of digital sensors

Pulse

The screenshot shows a configuration window for a digital sensor. The 'Channel type' is set to 'digital'. Under 'Measuring range', 'Impuls' is selected. 'Scaling type' is set to 'Standard'. The 'Signal minimum' is 0.0000 and 'Signal maximum' is 1.00. The 'Value minimum' is 0.0000 and 'Value maximum' is 1.0000. In the 'Limiting values' section, 'Minimum' is 0.0000 and 'Maximum' is 80.0000, with 'Underflow' and 'Overflow' both set to 'Error'. The 'Special function' is set to 'Off'. In the 'Processing' section, 'Value processing' is 'Sum precipitation without intensity correction', 'Measuring interval' is 80%, 'Sensor type' is 'Precipitation', and 'Precipitation factor' is 0.1000. A note states: 'One overturning = x.xx mm/m². Serial sensors: x.xx = 1.00'.

The upper figure shows the scaling for a precipitation sensor with reed switch. The pulses are recalculated minute by minute according to the correction of the intensity characteristic curve and multiplied by the rocker factor. In this case, a pulse = 0.1 mm/m² precipitation.

5.3.5.5.4 Channel type - Modbus

Ser[LOG] supports a subset of Modbus RTU and Modbus TCP. The measured values are not retrieved by the Ser[LOG] from the Modbus devices in a block, but each measured value is always retrieved individually. If the channel type Modbus is selected, the input mask shown below appears.

The screenshot shows a configuration window for a Modbus channel. The 'Channel type' is set to 'Modbus'. The 'Register' field contains the value '0'. The 'Data type' is set to 'Integer (16 Bit) signed'. The 'Endian' is set to 'Big Endian'. The 'Modbus command' is set to '(0x03) Read Holding Registers'. The 'Processing' is set to 'Standard - transfer value'. The 'Divisor' field contains the value '10'. The 'Timeout (ms)' is set to '1250'.

In the field "Register" the address of the start register for the measured value is entered.

The "Data type" determines how many registers are read. With "Integer (16Bit) signed" or "Word (16Bit) unsigned" one 16 bit register is read, with "Long Integer (32Bit) signed" or "Double Word (32Bit) unsigned" two 16 bit registers are read. In addition to the standardized data types Ser[LOG] also supports the type Real Single, a 32 bit floating point number. For this data type Ser[LOG] offers the following decodings independent of the endian setting:

Received byte sequence: abcd

Decoding abcd, dcba, badc, cdab

The last decoding form (cdab) is more common than the other three forms.

The standard bit sequence for Modbus is "Big Endian", but there are also devices that use "Little Endian". The respective bit sequence can be selected in the field "Endian".

The Ser[LOG] currently offers the Modbus functions 0x02, 0x03 and 0x04 for data retrieval in the "Modbus command" field.

The "processing" of the measured value during transfer from the Modbus protocol can be carried out according to the following rules:

Standard - Accept value only

The measured value is taken over directly and fed to the measured value processing.

Difference new value - old value

The difference is calculated from the previous measured value to the current measured value. Used, for example, to calculate the amount of precipitation from the total quantity since the device was started.

Percent from 0-1 is 0% to 100%

Used, for example, for status information that is to be processed in percent.

The "divisor" is the value by which the integer value is to be divided in order to obtain a floating-point value.

Since there is no standardized value for the timeout in the Modbus protocol, a timeout time for the measured value can be defined in steps of 250 ms in the field "Timeout".

5.3.5.5.5 Channel type - SDI-12

In Ser[LOG], the measured values of SDI-12 sensors are broken down into their measured value structure. Each measured value is defined as a separate "sensor".

The Ser[LOG] supports from the SDI-12 specification only the "CC" command to initialize the measurement in the SDI-12 device. Subsequently, as many D0 to D9 commands are sent until all announced measured values have been read in Ser[LOG].

For processing, a large data sequence is generated from all individual measured value sets, which is accessed by the SDI-12 sensor definitions.

A distinction is made between data types in:

Single measurement value	The measured value is stored individually as instantaneous value and transferred unchanged to a measurement channel.
Measured value group AVR/SUM, MIN, MAX	The sensor delivers the measured data as AVR=Average or SUM=Sum and as MIN=Minimum, MAX=Maximum

In the fields "Measured value position", "Minimum position" and "Maximum position" of the data type "Measured value group AVR/SUM, MIN, MAX" the position of the respective value in the data sequence is entered. For the data type "Single measurement", enter the same position in each of the 3 fields.

The "processing" of the measured value during transfer from the SDI-12 protocol can be carried out according to the following rules:

Standard - Accept value only	The measured value is taken over directly and fed to the measured value processing.
Difference new value - old value	The difference is calculated from the previous measured value to the current measured value. Used, for example, to calculate the amount of precipitation from the total quantity since the device was started.
Percent from 0-1 is 0% to 100%	Used, for example, for status information that is to be processed in percent.

Examples of SDI-12 sensors

<p>Channel type: <input type="text" value="SDI12"/></p> <p>Data type: <input type="text" value="Single value"/></p> <p>Value position: <input type="text" value="4"/></p> <p>Minimum position: <input type="text" value="4"/></p> <p>Maximum position: <input type="text" value="4"/></p> <p>Processing: <input type="text" value="Standard - transfer value"/></p>	In this example, a single measured value which is at the 4th position in the data sequence of the SDI-12 device is taken over and transferred unchanged to a measured value channel of the Ser[LOG].
<p>Channel type: <input type="text" value="SDI12"/></p> <p>Data type: <input type="text" value="Group of values AVR/SUM, MIN, MAX"/></p> <p>Value position: <input type="text" value="4"/></p> <p>Minimum position: <input type="text" value="11"/></p> <p>Maximum position: <input type="text" value="5"/></p> <p>Processing: <input type="text" value="Standard - transfer value"/></p>	This example shows how the measured values are taken from an SDI data set that provides average, minimum and maximum values for a measured value for the period from data retrieval to data retrieval.

5.3.5.5.6 Channel type - Serial (e. g. NMEA)

Several protocols for serial sensors are implemented in Ser[LOG]. Most serial sensors are already available as predefined sensors. To be able to access measured values retrieved with these protocols, a sensor is defined for each measured value.

Channel type:

Protocoll:

Value out of Prot.:

In the field "Protocol" the protocol for the sensor is selected, e. g. NMEA.

In the field "Value from report", the corresponding measured value is selected from the report.

The following values can be selected from the NMEA protocol:

MWV Wind Direction Relative	Relative wind direction from the \$WIMWV protocol
MWV Wind Speed Relative m/s	Relative wind speed in m/s from the \$WIMWV protocol
MWV Wind Speed Relative kt	Relative wind speed in kt from the \$WIMWV protocol
MWV Wind Speed Relative km/h	Relative wind speed in km/h from the \$WIMWV protocol
MWV Wind Direction True	True wind direction from the \$WIMWV protocol
MWV Wind Speed True m/s	True wind speed in m/s from the \$WIMWV protocol
MWV Wind Speed True kt	True wind speed in kt from the \$WIMWV protocol
MWV Wind Speed True km/h	True wind speed in km/h from the \$WIMWV protocol
MWD Wind Direction TRUE	True wind direction from the \$WIMWD protocol
MWD Wind Direction Magnetic	Magnetic wind direction from the \$WIMWD protocol
MWD Wind Speed kt	Relative wind speed in kt from the \$WIMWD protocol
MWD Wind Speed m/s	Relative wind speed in m/s from the \$WIMWD protocol
MTA Air Temperature °C	Air temperature from the \$WIMTA protocol
MTS Soil Temperature °C	Soil temperature from the \$WIMTS protocol
MTW Water Temperature °C	Water temperature from the \$WIMTW protocol
MMB Barometric Pressure hPa	Barometric air pressure in hPa from the \$WIMMB protocol
MMB Baro. Pressure Inch Hg	Barometric air pressure in Inch Hg from the \$WIMMB protocol
MHU Relative Humidity %	Relative humidity from the \$WIMHU protocol
MHU Dew Point Temperature °C	Dew point temperature in °C from the \$WIMHU protocol
MHU Absolute Humidity	Absolute humidity from the \$WIMHU protocol
OSD Heading	Heading from this protocol
OSD Vessel Course	Vessel Course from this protocol
OSD Vessel Speed kt	Vessel Speed kt from this protocol
HDT Heading	Heading from this protocol
VTG Vessel Course	Vessel Course from this protocol
VTG Vessel Speed kt	Vessel Speed kt from this protocol
VBW Vessel Course	Vessel Course from this protocol
VBW Vessel Speed kt	Vessel Speed kt from this protocol
XDR	Various values such as temperature, humidity, air pressure, etc.

5.3.5.5.7 Channel type - Virtual

Virtual sensors calculate measured values derived from other sensors or measured values. Most virtual sensors are already available as predefined sensors.

The screenshot shows a configuration window for a virtual sensor. It contains two dropdown menus: 'Channel type' which is currently set to 'virtual', and 'Formula' which is currently set to 'Free formula'.

In the "Calculation formula" field, a formula for determining the value is selected. The following standard functions are available:

Free formula	Input of a free formula with up to 5 measured values and 5 constants.
Dew point temperature (Psychrometer)	Calculation of the dew point temperature from dry temperature (sensor 1) and wet bulb temperature (sensor 2).
Relative humidity (Psychrometer)	Calculation of the relative humidity from dry temperature (sensor 1) and wet bulb temperature (sensor 2).
Dew point temperature (Thermo-Hygrometer)	Calculation of the dew point temperature from air temperature and humidity.
Relative humidity (air temperature & dew point temperature)	Calculation of relative humidity from air temperature and dew point temperature.
Absolute humidity	Calculation of the absolute humidity from air temperature and relative humidity.
QFE	Conversion of the air pressure to a different height than the height of the air pressure sensor. Positive and negative height differences are allowed
QFF	Reduction of the air pressure to normal zero, considering the current values for air pressure, dew point and temperature.
QNH	Reduction of atmospheric pressure to normal zero assuming a standard atmosphere
Wind direction from 3 partial voltages	This function is only for applications in marine meteorology.
Variance	Calculation of the variance of a selected parameter.
Standard deviation	Calculation of the standard deviation of a selected parameter.
PT/STB Selector	This function is intended for use in marine meteorology only.
Set NoValue	This function is intended for use in marine meteorology only.
Wind direction from 3 partial voltages N18	Wind direction from 3 partial voltages N18
Redundant Sensor	Two sensors are assigned to the virtual sensor. Of these, the first is the primary sensor and the second is the secondary sensor. As long as the primary sensor works and provides valid values, the value of the primary sensor is processed further. If the primary sensor does not work or provides invalid values, the value of the secondary sensor is processed further. If both sensors do not function, an error is output.
Meteorological visibility MOR	Calculation based on suitable measuring devices (FS11)
Horizontal visibility	Calculation based on suitable measuring devices (FS11)
Runway visibility RVR	Calculation based on suitable measuring devices (FS11)
Standard deviation (wind direction)	Calculation of the standard deviation of the wind direction.

Standard deviation (wind speed)	Calculation of the standard deviation of the wind speed.
Variance (wind direction)	Calculation of the variance of the wind direction.
Variance (wind speed)	Calculation of the variance of the wind speed.
Wind direction from sin / cos	Calculation of wind direction from cosine and sine signal.
Compass corrected wind direction	Calculation using HDT data set
Derived value	Output of 1/0 or 0...100 % based on threshold value
Vapor pressure	Calculation from temperature, humidity, and air pressure
Wet bulb temperature	Reverse calculation from temperature, humidity, and air pressure
Status switching output	1 with triggered switching output 0 with not triggered switching output.

The input parameters for the respective formula are assigned during configuration of the measurement channels in the mask "Definition of virtual sensor".

5.3.5.5.8 Special function for sensor definition

If in the "Sensor Definition" window for the limit values it is set that an error should be triggered when the limit value is exceeded or underrun, then this error can be intercepted and assigned to a "special function" in the frame of the same name.

By default, the special function is set to "Off" and is therefore deactivated. The following special functions are available:

Value < Minimum ==> 0	If the value falls below the permissible minimum value, the value is set to "0". In this case, the field "Underrun" must be set to "Error".
Wind direction measurement with potentiometer	When measuring the wind direction with a potentiometer with a gap, the direction value is set to North (360°) when the potentiometer is in the gap. In this case, the fields "underrun" and "overrun" must both be set to "error".
Wind direction measurement with potentiometer N18	When measuring the wind direction with a potentiometer with a gap turned by 180°, the direction value is set to North (180°) when the potentiometer is in the gap. In this case, the fields "underrun" and "overrun" must both be set to "error".
Wind direction N18	The output signal of the wind direction sensor is rotated by 180°.
Service switch	If a status input is defined as a "service switch", the mean value storage is suspended as long as the service state is > 0.

5.4 Displaying instantaneous values

The Ser[LOG]-Commander offers a simple display of the current measured values per channel in tabular form. The current values can be called up in the "Standard" display as scaled values, in the "RAW" display as raw values and in the "UDP" display as fast data retrieval via UDP.



The current value display is opened by pressing the  button.

In the selection field in the upper left corner, select the station from which the current values are to be retrieved.

Note: Please note that the Ser[LOG] must be connected to the PC via the interface configured for the respective station. If necessary, adjust the interface in the "Ser[LOG] configuration". See also chapter 5.3.1.1, chapter 5.3.1.2 and chapter 5.3.4.

5.4.1 Standard instantaneous value display



By pressing the "Start instantaneous values" button, the instantaneous value retrieval is started in standard mode and the current scaled instantaneous values are displayed.

Sensor	Value	Sensor	Value	Sensor	Value
S01-DA	Status	0	---	S21	
S02-DB				S22	Dewpoint
S03-1A01	Temperature	23.2	Deg. C	S23	No-S-Da
S04-1A02	Temperature	23.9	Deg. C	S24	
S05-1A03	Temperature	22.0	Deg. C	S25	
S06-1A04	Temperature	0.0	Deg. C	S26	
S07-1A05				S27	
S08-1A06	rel. Humidity	Open-Ch	%	S28	
S09-1A07				S29	
S10-1A08	Wind Speed	Open-Ch	m/s	S30	
S11-1A09	Wind Direction	Open-Ch	Deg.	S31	
S12-1A10				S32	
S13-1A11				S33	
S14-1A12				S34	
S15-1D01	Precipitation	0.0	mm	S35	
S16-1D02				S36	
S17-1D03				S37	
S18	Precip Amount	0.000	mm/qn	S38	
S19				S39	
S20				S40	
				S41	
				S42	
				S43	
				S44	
				S45	
				S46	
				S47	
				S48	
				S49	
				S50	
				S51	
				S52	
				S53	
				S54	
				S55	
				S56	
				S57	
				S58	
				S59	
				S60	

Date / Time: 19.02.2018 11:40:32

In this mask the actual measured values of Ser[LOG] are displayed. In the column Measured value, the red entries indicate the errors that occur on the respective channel. In this case, no sensor is connected to Ser[LOG].

On the analog channels it is determined that no sensor is connected, and the channel is open. This cannot be detected on the digital channels. Serial channels indicate that no serial data is present.



The button  stops the data retrieval.

5.4.2 Display of the current electrical raw values



Pressing the button "Start raw values" starts the instantaneous value recall in RAW mode and the current unscaled electrical instantaneous values are displayed. The raw value display only works for the analog channels.

The screenshot shows a software window titled 'Momentanwerte --- Rohwerte ---'. It features a toolbar with icons for settings, RAW, UDP, stop, and refresh. A dropdown menu shows 'Station: Test'. Below the toolbar are tabs for 'Instant. values' and 'Wind values'. The main area contains a table with columns for Sensor, Value, and Sensor. The table lists various sensors (S01-DA to S60) and their corresponding values and units. Some values are 'No-Value' or '---', while others are numerical values with units like 'Deg. C', 'm/s', and 'mm'. At the bottom, a status bar shows 'Date / Time: 19.02.2018 11.41.38'.

Sensor	Value	Sensor	Value	Sensor	Value
S01-DA	Status	No-Value	---	S21	
S02-DB				S22	Dewpoint
S03-1A01	Temperature	109.0521	Deg. C	S23	
S04-1A02	Temperature	109.2974	Deg. C	S24	
S05-1A03	Temperature	108.5694	Deg. C	S25	
S06-1A04	Temperature	100.0000	Deg. C	S26	
S07-1A05				S27	
S08-1A06	rel. Humidity	0.0206	%	S28	
S09-1A07				S29	
S10-1A08	Wind Speed	0.0206	m/s	S30	
S11-1A09	Wind Direction	0.0198	Deg.	S31	
S12-1A10				S32	
S13-1A11				S33	
S14-1A12				S34	
S15-1D01	Precipitation	No-Value	mm	S35	
S16-1D02				S36	
S17-1D03				S37	
S18	Precip Amount	No-Value	mm/qn	S38	
S19				S39	
S20				S40	
				S41	
				S42	
				S43	
				S44	
				S45	
				S46	
				S47	
				S48	
				S49	
				S50	
				S51	
				S52	
				S53	
				S54	
				S55	
				S56	
				S57	
				S58	
				S59	
				S60	



The button stops the data retrieval.

5.4.3 Instantaneous value display via UDP

The instantaneous value display via UDP only works via network or Ethernet. For this purpose, the corresponding UDP port (standard port 4649) must be entered in the Ser[LOG] configuration (chapter 5.3.4.1) of the PC setting (chapter 5.3.4).



Pressing the "Start UDP instantaneous values" button starts the fast instantaneous value retrieval via UDP and the current scaled instantaneous values are displayed.



The button stops the data retrieval.

5.4.4 Display of moving wind data

In the "Wind data" tab, moving average values of up to two wind pairs are displayed. The wind pairs are configured in the Ser[LOG] configuration on the "Wind data" tab. See also chapter 8.

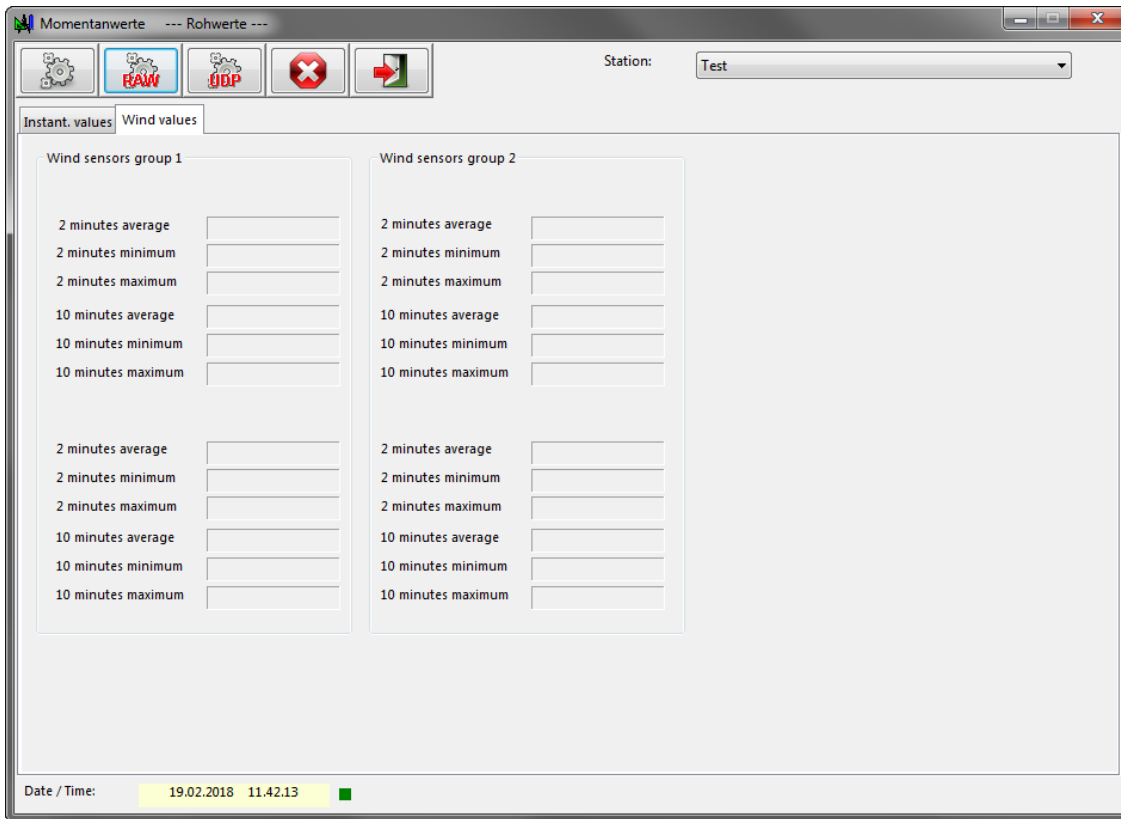

The wind data can only be displayed with the standard polling or the UDP polling. The raw value display does not work for the wind data.



The button  stops the data retrieval.

5.4.5 Error messages of the instantaneous values

The following error messages may occur in the various instantaneous value displays:

Open-Ch	Open Channel - The Ser[LOG] can detect whether a sensor is actually connected to an analog input. The error is displayed if no sensor is detected or connected to the corresponding analog input. Possible causes: Sensor not connected, sensor defective, cable break.
No-S-Data	No-Serial-Data - If a serial sensor does not send any data, Ser[LOG] detects this and displays the error.
Bad-Sig	The present signal (analog or serial) cannot be evaluated.
Ov-Flow	Over-Flow - The maximum permissible measurement value has been exceeded.
Un-Flow	Under-Flow - The measured value has fallen below the minimum permissible value.
No-Value	No-Value - There is no valid measured value or no valid value can be supplied.

5.5 Recalling and saving measured values



Pressing the  button opens the window for retrieving (exporting) the stored averages and extreme values (if saved).

In the "Station" selection box, select the name of the station from which the averages are to be retrieved.

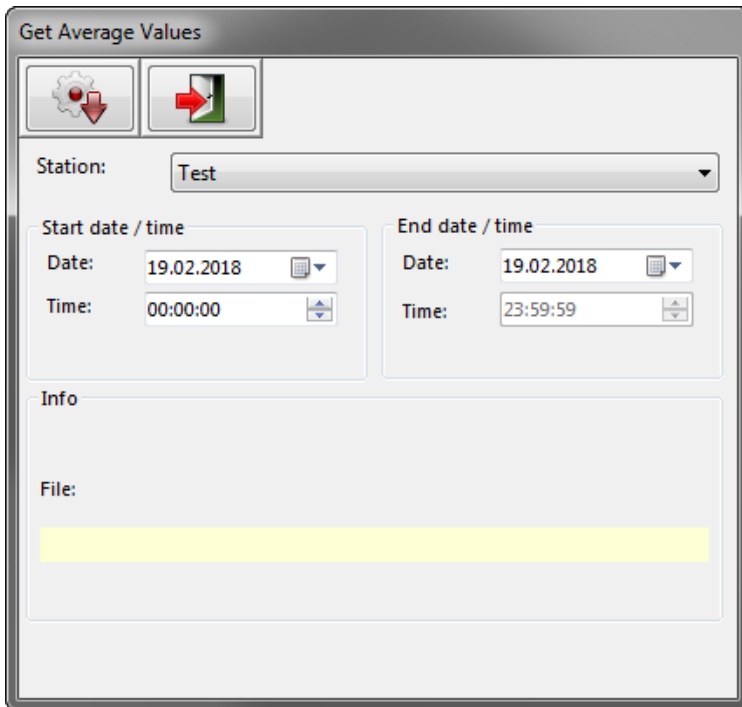

Then select the time period for retrieving the data. In the case of "Retrieval period end", the default time is 23:59:59.



Pressing the "Start measured value retrieval" button  opens a Windows file dialog in which the file for data storage can be defined.

The data is then retrieved and stored in CSV format. If a file with the same name already exists, the old data is overwritten. Attaching the data to existing files is not possible.

The used field separators and the decimal characters that are used can be set under "Other functions"

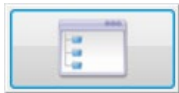

, "CSV settings".

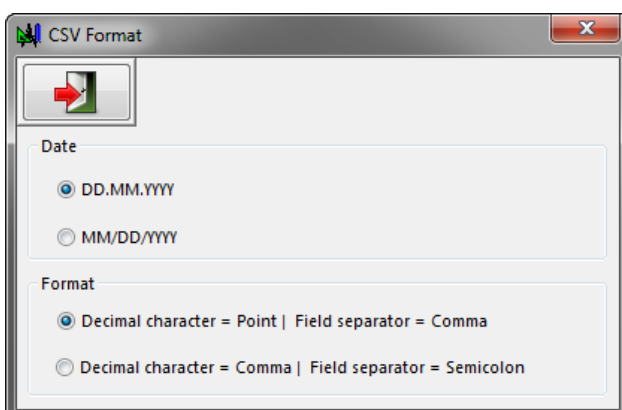

In this menu, you can define the date format and the decimal point / field separator for formatting the stored measured values.

5.6 Display measurement data

The Ser[LOG]-Commander files can be evaluated, edited, and visualized with standard office programs using the export function (call up measured values). For simple tabular visualization, the Ser[LOG] offers



the function "Display measurement data". The function is started by pressing the button.

The call of this function opens a Windows file dialog in which the data file can be selected. The data is displayed directly in tabular form.

Datum	Zeit	Netzausfall	Netzausfall...	Netzausfall...	TA200	TA200 Min.	TA200 Max.	TA020	TA020 Min.	TA020 Max.	TS005
29.01.2018	24:00:00	0	0	0	5.4	5.3	5.4	5.4	5.4	5.5	3.9
30.01.2018	00:10:00	0	0	0	5.4	5.3	5.5	5.6	5.4	5.7	3.9
30.01.2018	00:20:00	0	0	0	5.4	5.3	5.5	5.4	5.2	5.7	3.9
30.01.2018	00:30:00	0	0	0	5.3	5.2	5.3	5.3	5.1	5.4	3.8
30.01.2018	00:40:00	0	0	0	5.2	5.2	5.2	5.1	5	5.2	3.8

5.7 Display measurement data graphically



The call of starts the graphical evaluation. After selecting the data file to be evaluated, two measured value series are selected for display.

Auswahl Messwerte

Zeitreihe 1: S05_A_Temperature__AVR

Zeitreihe 2: S06_A_Rel.. Humidity__AVR

-
- S01_A_Precipitation__AVR
- S01_-_Precipitation__MIN
- S01+_Precipitation__MAX
- S03_A_Wind Direction__AVR
- S03_-_Wind Direction__MIN
- S03+_Wind Direction__MAX
- S04_A_Wind Speed__AVR
- S04_-_Wind Speed__MIN
- S04+_Wind Speed__MAX
- S05_A_Temperature__AVR
- S05_-_Temperature__MIN
- S05+_Temperature__MAX
- S06_A_Rel.. Humidity__AVR**
- S06_-_Rel.. Humidity__MIN
- S06+_Rel.. Humidity__MAX
- S07_A_Dewpoint__AVR
- S07_-_Dewpoint__MIN
- S07+_Dewpoint__MAX
- S08_A_Air Pressure__AVR
- S08_-_Air Pressure__MIN
- S08+_Air Pressure__MAX

This choice leads to the following graph:



6 IP Communication

The Ser[LOG] supports the IP-based functions:

- NTP
- FTP
- Email

In addition, it is possible to send simple SMS messages in case of alarms.

These functions are configured in the register "IP communication" in the configuration window of the Ser[LOG].

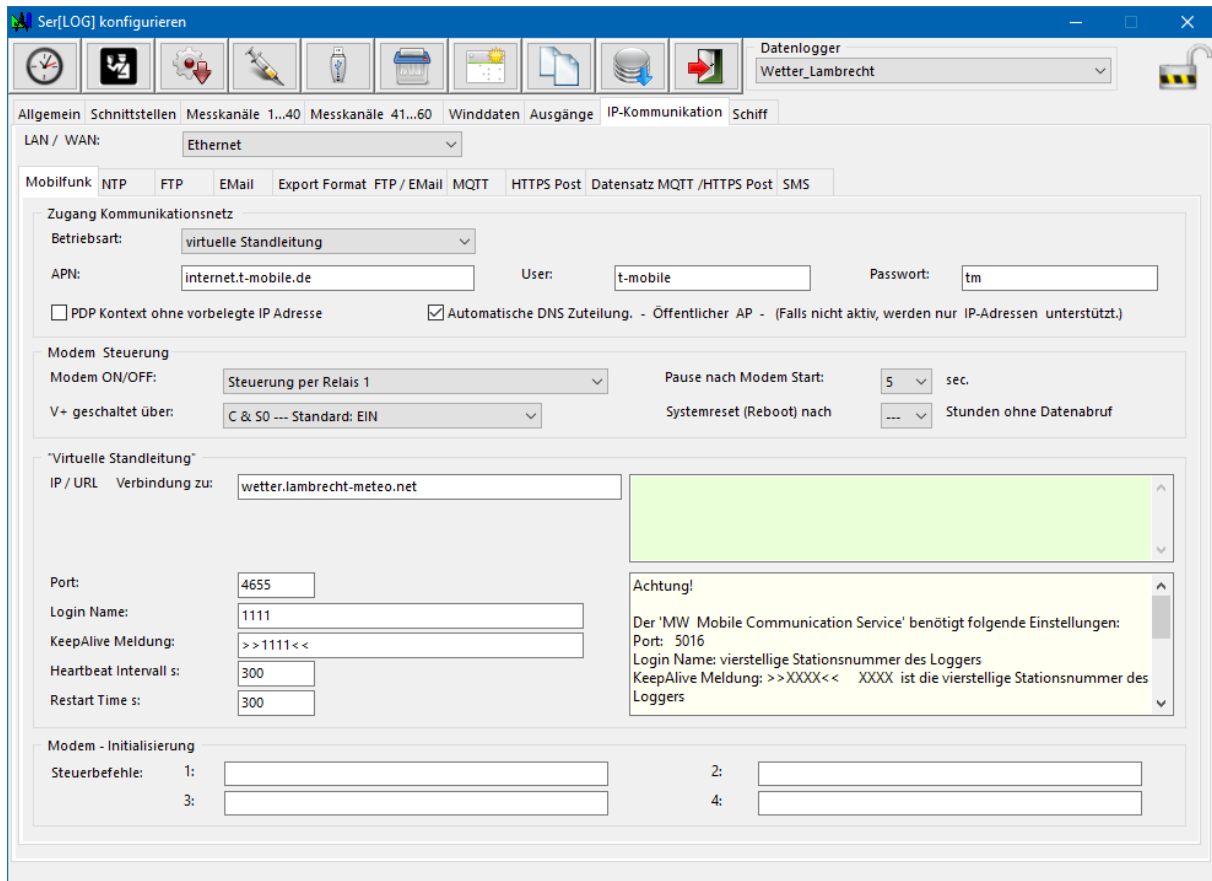

In the superordinate field "LAN / WAN" it is determined whether the communication for "NTP", "FTP" and "E-Mail" should take place via GPRS modem or via network interface. SMS "messages are only possible if a modem is used.

GPRS stands for 2G, 3G, 4G mobile communications. The type of modem used, and the service provider's SIM card determine the type of connection. Modems from different manufacturers can be used, provided that they support "PPP" (Point-to-Point Protocol).

All functions of the "IP Communication" tab and its sub-tabs can be deactivated with "IP OFF" in the "LAN / WAN" selection box.

In the sub-tabs "GPRS", "NTP", "FTP", "Email", "MQTT", "HTTPS post", "SMS", "Export Format" and "Dataset MQTT / HTTPSPost" the configuration of the corresponding functions is done. These are described in the following subchapters.

6.1.1.1 Synchronization of the clock via NTP

Ser[LOG] is able to adjust its internal real-time clock via NTP. The NTP server is entered in the "Server Name" field. Since NTP returns the time in UTC format, the time deviation of UTC is entered in the "Time Offset" field.

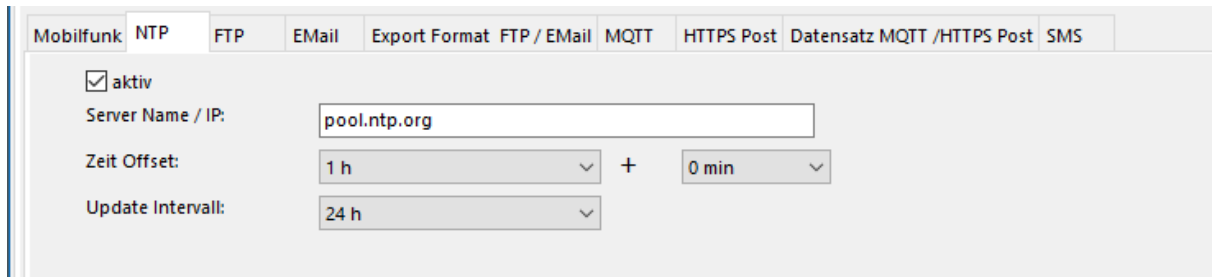

The field "Update interval" is for the configuration of the interval when the clock synchronization should take place.

6.1.1.2 Data Transfer via FTP - Ser[LOG] as FTP Client

Ser[LOG] has an FTP client. Measured values can be transferred to an FTP server via FTP. Currently only unsecured FTP is supported. The checkbox "active" activates the FTP function. Up to 2 servers are supported. If the primary server ("Server 1") is not available, the secondary server ("Server 2") is used. The default port for FTP is port 21.

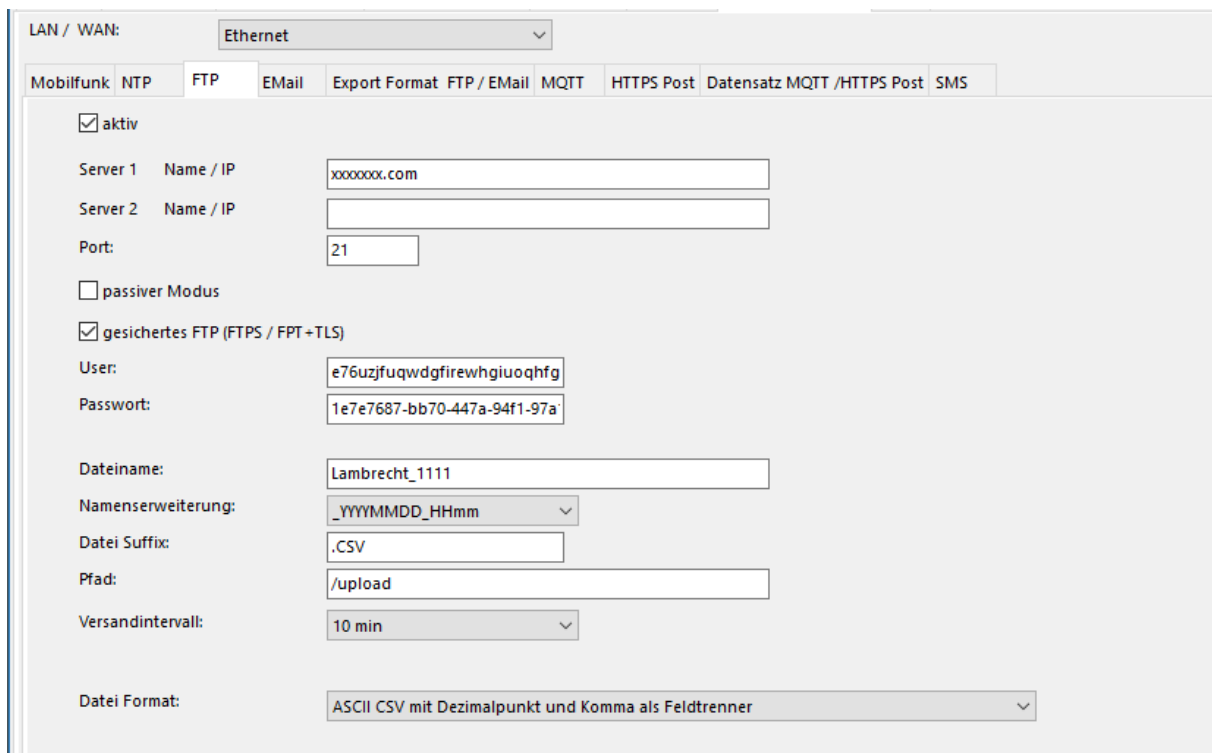

Ser[LOG] works in active mode by default but can also be switched to passive FTP via the checkbox "passive mode". If the server[LOG] is behind a firewall, the firewall may block an incoming connection while FTP is active. In this case, you should switch to passive FTP (passive mode).

The login data for the FTP server are entered in the fields "User" and "Password".

The "File name" field defines the main name element for the data storage. If you want to avoid overwriting data, you can activate _YYYYMMDD_HHmm in the field "Name extension". This means that the main component is extended by the date and time of the transmission each time the data is saved.

In the "File suffix" field, the file name extension is entered in the ". xxx" format, e. g. "csv".

The "Path" field specifies the directory below the FTP root directory (for the logged-on user) in which the data is to be stored.

In the selection field "Dispatch interval" you can set the interval or time at which the data is stored on the FTP server.

Available for selection:

- | <u>Interval</u> | <u>Time (full hour)</u> | |
|-----------------|-------------------------|---------|
| • 10 minutes | • 00:00 | • 12:00 |
| • 30 minutes | • 01:00 | • 13:00 |
| • 60 minutes | • 02:00 | • 14:00 |
| • 120 minutes | • 03:00 | • 15:00 |
| • 180 minutes | • 04:00 | • 16:00 |
| • 240 minutes | • 05:00 | • 17:00 |
| • 360 minutes | • 06:00 | • 18:00 |
| • 480 minutes | • 07:00 | • 19:00 |
| • 720 minutes | • 08:00 | • 20:00 |
| • 1440 minutes | • 09:00 | • 21:00 |
| | • 10:00 | • 22:00 |
| | • 11:00 | • 23:00 |

Note: If the function is used in conjunction with mobile communication, a transmission interval of less than 30 minutes is not recommended for a poor network connection.

The stored data is sent from one transmission to the next. The maximum extent of the data is limited to a period of up to one month.

The data for FTP export can be defined in 2 binary and 2 ASCII formats:

64 bit binary with Unix date	Standard binary file in 64Bit REAL IEEE format. (Sequence of the data, as defined in Settings for the export format.)
32 bit binary with Unix date	Binary file in 32Bit REAL IEEE format. (Sequence of the data, as defined in Settings for the export format.)
ASCII CSV with decimal point and comma as field separator	CSV export file comma as field separator and decimal point (0.1). (Sequence of the data, as defined in Settings for the export format.)
ASCII CSV with decimal point and semi-colon as field separator	CSV export file semicolon as field separator and decimal point (0.1). (Sequence of the data, as defined in Settings for the export format.)

The sequence of the data and its information content for FTP export is defined in the settings for the "Export format". See chapter 6.1.1.4.

6.1.1.3 Transmission of measured values via Email / Email alarm

The Ser[LOG] can send alarm messages or measured values via email. The checkbox "active" activates the email function. Then the usual access data to the mail server must be entered. The email address of the sender, the email addresses of the recipients (if necessary, with CC address) and the subject are entered underneath.

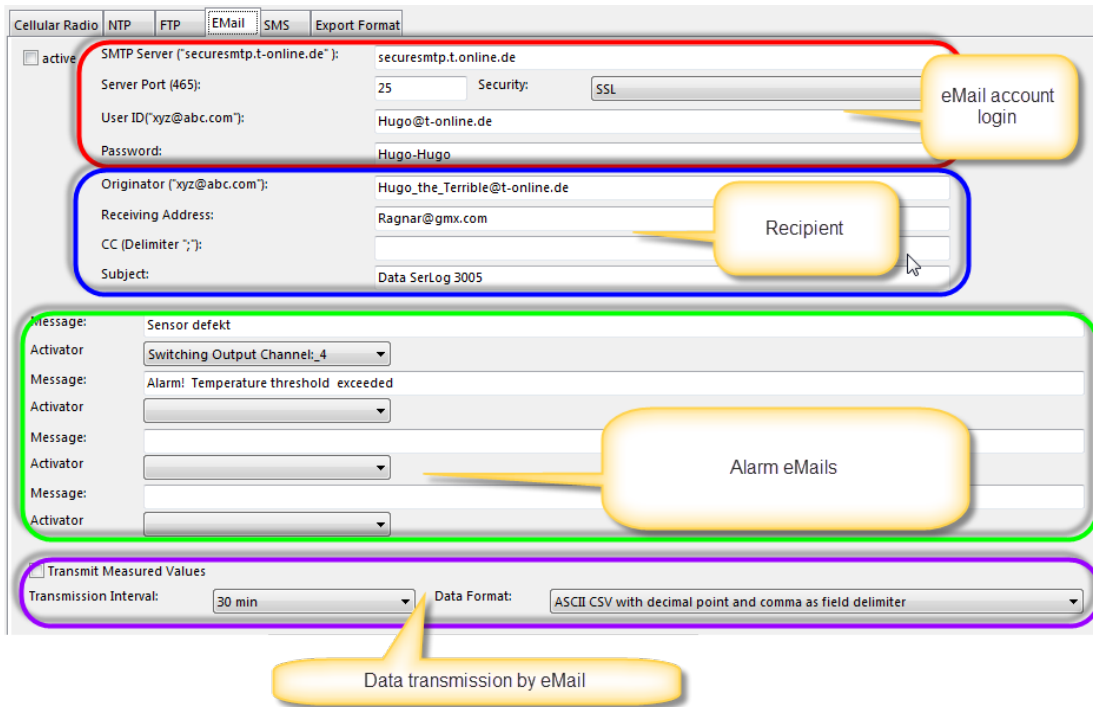

Alarm emails

Up to 4 different warning emails can be sent. In the fields "Message 1-4" the corresponding alarm text is entered and, in the field, "Initiator" the switching channel is defined, which triggers the dispatch of the emails. See also chapter 7 "Configuration of the switching outputs and alarms".

Transmission of measured values via email

If you also want to send data via email, the checkbox "Measured value transmission active" is selected.

In the selection field "Dispatch interval" you can set the interval or time at which the data will be sent by email. There is a choice:

- | <u>Interval</u> | <u>Time (full hour)</u> | |
|-----------------|-------------------------|---------|
| • 10 minutes | • 00:00 | • 12:00 |
| • 30 minutes | • 01:00 | • 13:00 |
| • 60 minutes | • 02:00 | • 14:00 |
| • 120 minutes | • 03:00 | • 15:00 |
| • 180 minutes | • 04:00 | • 16:00 |
| • 240 minutes | • 05:00 | • 17:00 |
| • 360 minutes | • 06:00 | • 18:00 |
| • 480 minutes | • 07:00 | • 19:00 |
| • 720 minutes | • 08:00 | • 20:00 |
| • 1440 minutes | • 09:00 | • 21:00 |
| | • 10:00 | • 22:00 |
| | • 11:00 | • 23:00 |

Note: If the function is used in conjunction with mobile communication, a transmission interval of less than 30 minutes is not recommended for a poor network connection.

The stored data is sent from one transmission to the next. The maximum extent of the data can be traced back to a period of up to 3 days. The data is sent directly in the text of the email. A file is not appended.

The data for e-mail dispatch can be defined in 2 ASCII formats:

ASCII CSV with decimal point and comma as field separator

CSV export file comma as field separator and decimal point (0.1). (Sequence of the data, as defined in Settings for the export format.)

ASCII CSV with decimal point and semicolon as field separator

CSV export file semicolon as field separator and decimal point (0.1). (Sequence of the data, as defined in Settings for the export format.)

The order of the data and its information content for e-mail transmission is defined in the settings for the "Export format". See chapter 6.1.1.4

6.1.1.4 Setting the Export Format for FTP and Email

The information content of the export files for FTP and email is defined in the "Export Format" tab. A total of 60 channels can be selected according to their configuration (chapter 5.3.6).

Cellular Radio					NTP					FTP					EMail					SMS					Export Format				
	Sensor ID										Average	Minimum	Maximum																
1	S03 E_08090.231010_Temperature_PT100										<input checked="" type="checkbox"/>	<input checked="" type="checkbox"/>	<input checked="" type="checkbox"/>																
2	S06 E_08090.231010_Temperature_PT100										<input checked="" type="checkbox"/>	<input checked="" type="checkbox"/>	<input checked="" type="checkbox"/>																
3	S10 E_14522.100040_WS_Pro_4-20_75m/s										<input checked="" type="checkbox"/>	<input checked="" type="checkbox"/>	<input checked="" type="checkbox"/>																
4	S11 E_14521.100040_WD_Prof_4-20mA										<input checked="" type="checkbox"/>	<input checked="" type="checkbox"/>	<input checked="" type="checkbox"/>																
5	S15 E_15189.002000_Rain_2ccm_8mm										<input checked="" type="checkbox"/>	<input type="checkbox"/>	<input type="checkbox"/>																
6	---										<input type="checkbox"/>	<input type="checkbox"/>	<input type="checkbox"/>																
7	---										<input type="checkbox"/>	<input type="checkbox"/>	<input type="checkbox"/>																
8	---										<input type="checkbox"/>	<input type="checkbox"/>	<input type="checkbox"/>																
9	---										<input type="checkbox"/>	<input type="checkbox"/>	<input type="checkbox"/>																
10	---										<input type="checkbox"/>	<input type="checkbox"/>	<input type="checkbox"/>																
11	---										<input type="checkbox"/>	<input type="checkbox"/>	<input type="checkbox"/>																
12	---										<input type="checkbox"/>	<input type="checkbox"/>	<input type="checkbox"/>																
13	---										<input type="checkbox"/>	<input type="checkbox"/>	<input type="checkbox"/>																
14	---										<input type="checkbox"/>	<input type="checkbox"/>	<input type="checkbox"/>																
15	---										<input type="checkbox"/>	<input type="checkbox"/>	<input type="checkbox"/>																
16	---										<input type="checkbox"/>	<input type="checkbox"/>	<input type="checkbox"/>																
17	---										<input type="checkbox"/>	<input type="checkbox"/>	<input type="checkbox"/>																
18	---										<input type="checkbox"/>	<input type="checkbox"/>	<input type="checkbox"/>																
19	---										<input type="checkbox"/>	<input type="checkbox"/>	<input type="checkbox"/>																
20	---										<input type="checkbox"/>	<input type="checkbox"/>	<input type="checkbox"/>																
21	---										<input type="checkbox"/>	<input type="checkbox"/>	<input type="checkbox"/>																
22	---										<input type="checkbox"/>	<input type="checkbox"/>	<input type="checkbox"/>																
23	---										<input type="checkbox"/>	<input type="checkbox"/>	<input type="checkbox"/>																
24	---										<input type="checkbox"/>	<input type="checkbox"/>	<input type="checkbox"/>																

File Header:

The sensors are selected in the column "Sensor". In the columns "Average", "Minimum" and "Maximum" you can set the type of value that should be transferred.

Note: If you want to transfer the extreme values minimum and maximum, then the checkbox "Extreme value storage" must be activated in the "General" tab of the operating modes.

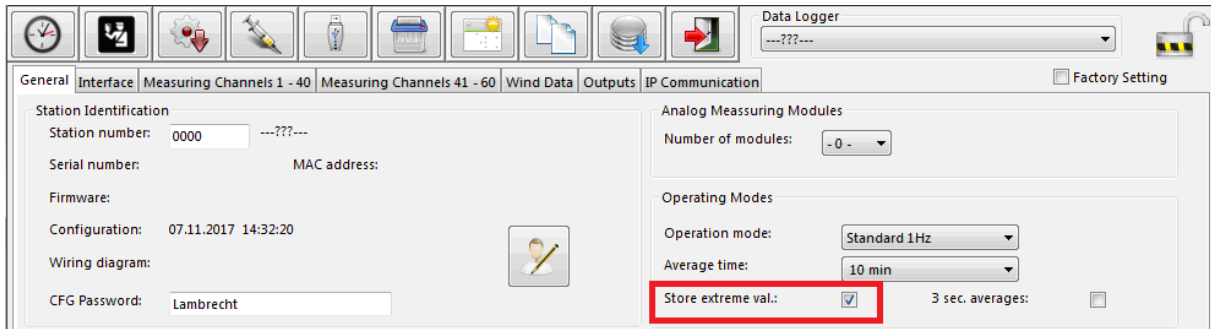

In the field "File header" you can define which information will be placed in front of the measured values during export. Available for selection:

- no header
- 1 line - sensor identification
- 2 lines - sensor identifier / unit
- 3 lines - Station identification / Sensor identification / Unit
- 4 lines - Station identification / Sensor identification / Sensor type / Unit

6.1.1.5 Ser[LOG] & SYNMET_IIA – Neue Features MQTT & HTTPS Post

The firmware of the Lambrecht data loggers Ser[LOG] and SYNMET_IIA is now extended by communication protocols MQTT and HTTPS Post.

6.1.1.6 Settings MQTT

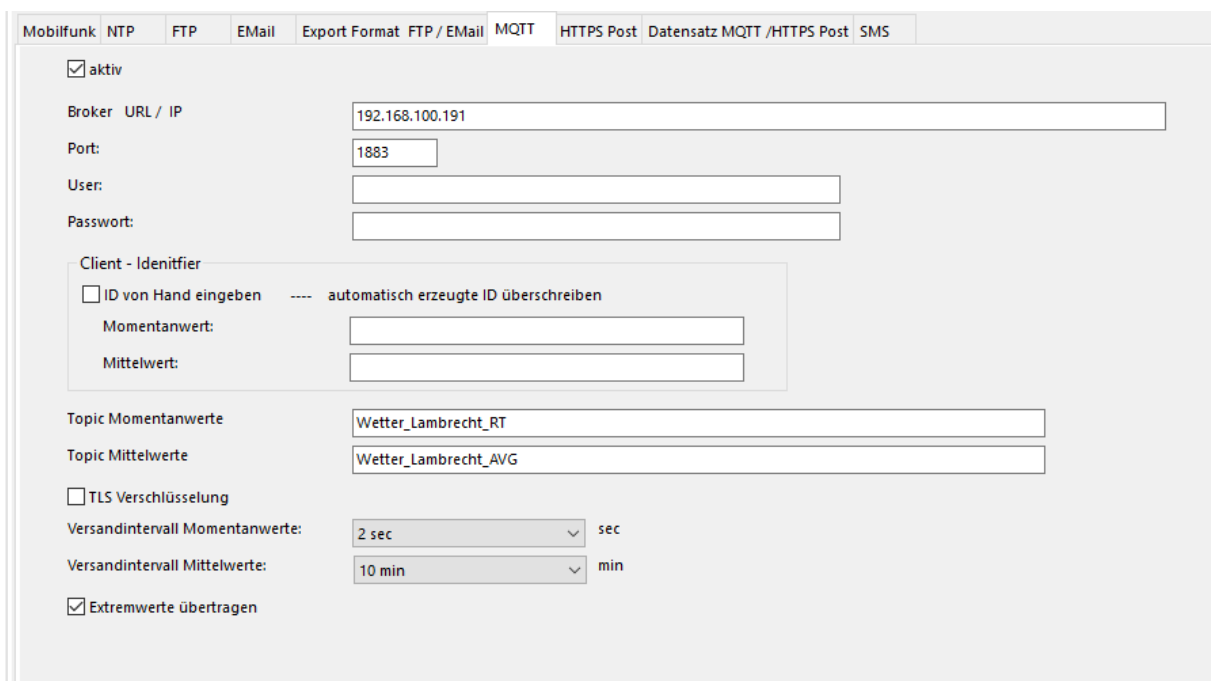

MQTT Logger Configuration (Target):

Setup Ser[LOG] *A_M*

Data Logger: Entwicklung

General | Interface | Measuring Channels 1 - 40 | Measuring Channels 41 - 60 | Wind Data | Outputs | IP Communication | Vessel Wind System - Ser[LOG] NAV only | Factory Setting

LAN / WAN: GPRS / EDGE / UMTS / HSDPA / LTE

Cellular Radio | NTP | FTP | Email | Export Format FTP / Email | **MQTT** | HTTPS Post | Data Record MQTT/HTTPS Post | SMS

active

MQTT Broker URL / IP: 87.140.127.24

Port: 1883

User:

Password:

Topic realtime values: Ser[LOG]_RT

Topic average values: Ser[LOG]_AVG

TLS encryption

Interval realtime values: 10 sec sec

Interval average values: 1 min min

Include extreme values

Lambrecht data logger support MQTT with realtime values (interval: 1, 2, 5, 10, 15, 20, 30 60 second) depending on the quality of data transmission (Ethernet connections support the shorter intervals). Realtime values are using its own topic on the Broker. They are transmitted with quality of service 0.

Average and extreme values are transmitted to the broker in intervals of 1, 2, 3, 5, 6, 10, 15, 20, 30 and 60 minutes. These intervals are the same time steps as used to calculate average values. A transmission interval longer than the average values calculation interval may be used. A shorter transmission interval must not be used. Average and extreme values support quality of service 1. They use an own topic on the Broker.

TLS encryption can be used to support a more secure MQTT transmission. It produces a significant higher load at the processor of the data logger and a much higher data transmission volume.

The MQTT Device ID is created automatically based on the MAC address of the data logger.

6.1.1.7 Settings HTTPS Post

Mobilfunk | NTP | FTP | Email | Export Format FTP / Email | MQTT | **HTTPS Post** | Datensatz MQTT / HTTPS Post | SMS

aktiv

Host URL / IP (HTTP(S)://URL) https://portal.lambrecht-meteo.net

Ressource /meteoconnect.php

Schlüsselbezeichnung: Key

Schlüssel Wetter_Lambrecht

Versandintervall Meta-Daten: Beim Start und jeden Tag h

Versandintervall Momentanwerte: 2 sec sec

Versandintervall Mittelwerte: 10 min min

Extremwerte übertragen

OK - Rückmeldung: true

HTTPS Post Logger Configuration (Target):

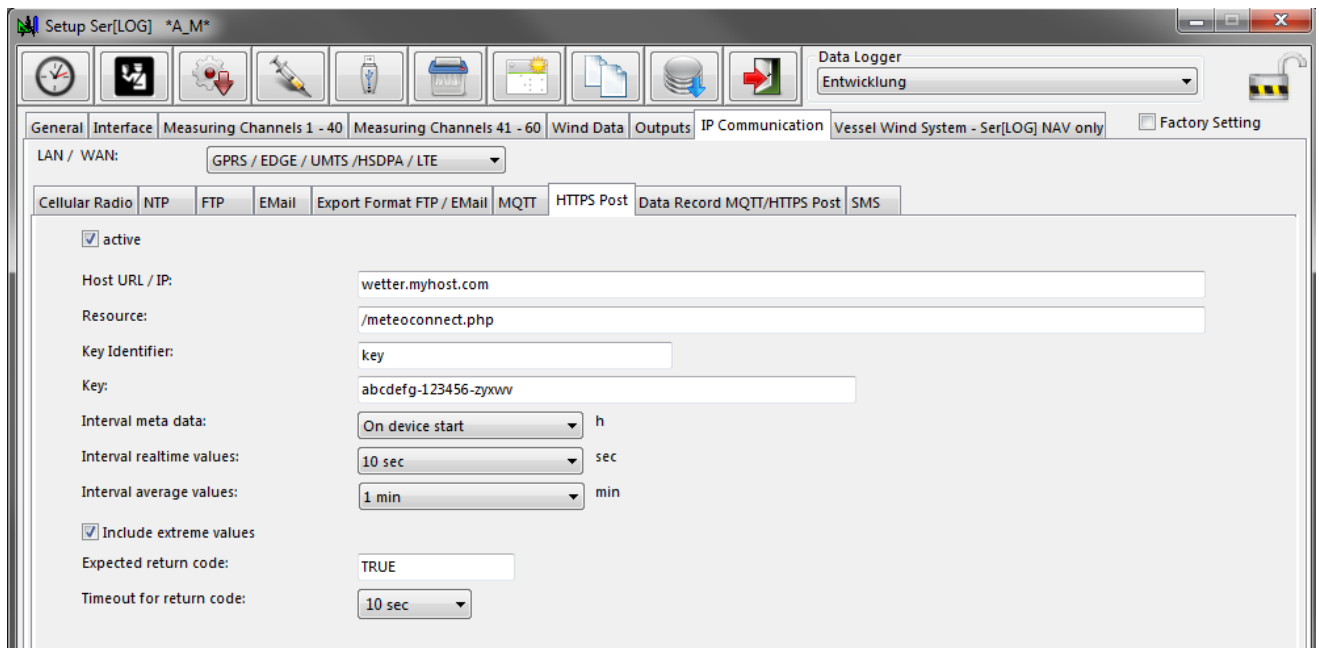

The screenshot shows the 'Setup Ser[LOG] *A_M*' window with the 'HTTPS Post' tab selected. The configuration is as follows:

- active
- Host URL / IP:
- Resource:
- Key Identifier:
- Key:
- Interval meta data: h
- Interval realtime values: sec
- Interval average values: min
- Include extreme values
- Expected return code:
- Timeout for return code:

Lambrecht data logger support HTTPS Post with realtime values (interval: 1, 2, 5, 10, 15, 20, 30 60 second) depending on the quality of data transmission (Ethernet connections support the shorter intervals).

Average and extreme values are transmitted to the Broker in intervals of 1, 2, 3, 5, 6, 10, 15, 20, 30 and 60 minutes. These intervals are the same time steps as used to calculate average values. A transmission interval longer than the average values calculation interval may be used. A shorter transmission interval must not be used.

Meta data containing descriptive information about the data logger and its sensors may be transmitted when the data logger is booting (for example after changing the configuration), or once a day. These information may be used for an automatic configuration on the target host.

6.1.1.8 Data Record Setup Logger Configuration (MQTT / HTTPS Post)

Lambrecht data logger support up to 60 sensors (measuring channels). Some of channels may be used for holding intermediate results for calculation of virtual sensors. These results are not of interest in the data record for MQTT or HTTPS Post. The content of these records may be defined by selection out of the available sensors. In this context a new designation may be given to the measured values.

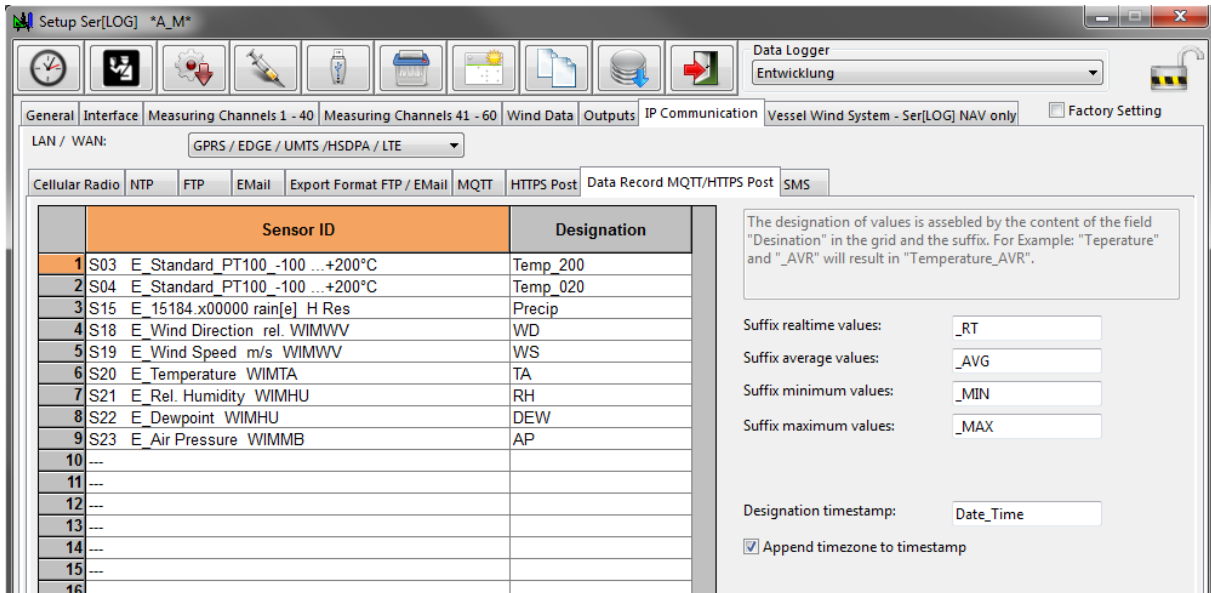

The value designation is extended by the editable suffixes.

For example:

The first selected value will be transmitted as:

Temp_200_RT (realtime value)

Temp_200_AVG (average value)

Temp_200_MIN (minimum value)

Temp_200_MAX (maximum value)

The designation of the timestamp is editable too.

The user may select to add timezone information to the time stamp.

6.1.1.9 Settings for IP communication via mobile radio modem

Modems from different manufacturers can be used for IP-based communication, provided that they support "PPP" (Point-to-Point Protocol).

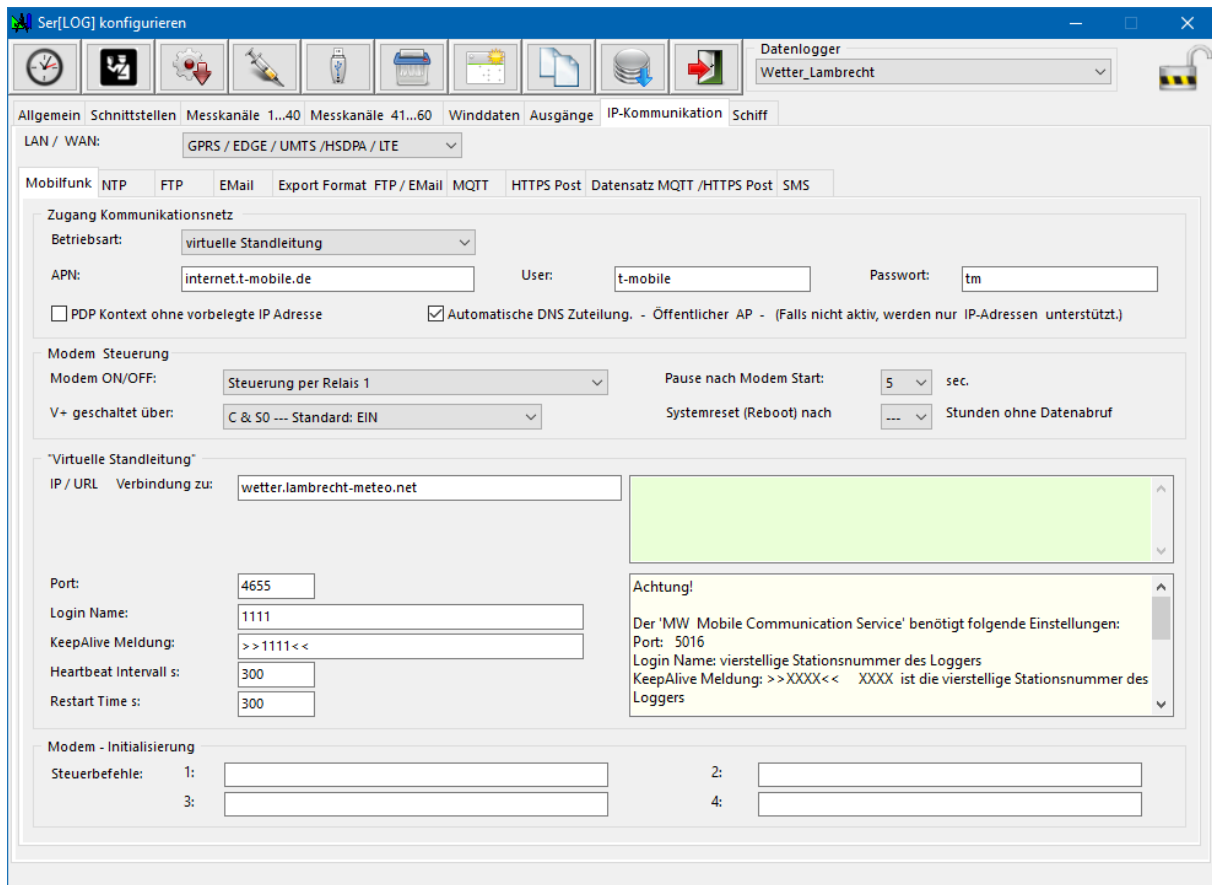

In the field "Operating mode" you can choose between

- „virtual leased line“ or
- „GPRS on demand“.

With the "virtual leased line", the Ser[LOG] establishes a connection to the Lambrecht application "MeteoWare CS4" or "MeteoWare-Net-Center".

With "GPRS on demand" only one connection to the Internet is established. For both types, Ser[LOG] can use "NTP", "FTP" and "Email". If "SMS" is activated, the data connection (2G, 3G, 4G) is terminated and an SMS connection is established every time an SMS is sent. During this time SER[LOG] cannot use NTP, FTP and Email. After sending the SMS, the data connection is re-established.

The access data to the mobile network of the service provider are entered in the fields "APN", "User" and "Password".

If you are communicating with a public APN, activate the checkbox "Automatic DNS assignment" (default).

If you are working with a private APN, this checkbox must be deactivated. In this case, only the IP addresses available behind the private APN can be used. This applies to the "virtual leased line", "NTP", "FTP" and "Email". SMS sending is not supported for private APNs.

Note: The use of a private APN requires the use of special SIM cards issued by the respective network operators. These cards usually do not support SMS sending.

In the "virtual leased line" frame, you can define the target computer ("IP / Domain Name") for which the leased line is set up.

In the "Port" field, please enter the port number on which the target computer can be reached (default value 5016).

The "Login Name" and "KeepAlive Message" fields are automatically assigned the station number by the system. The necessary unique station number should be mentioned here.

In the field "Heartbeat Interval" the entry is made, after how many seconds a KeepAlive message should be sent without communication of the Ser[LOG] (default value 300). If the KeepAlive messages cannot be triggered, the connection is restarted after the time specified in the "Restart Time" field.

Additional control commands for the modem can be entered in the Modem initialization frame. As a rule, this is not necessary.

6.1.1.10 Setting SMS alarm

The Ser[LOG] can send up to 4 different alarm messages via SMS.

Note: The use of SMS for alarm messages only works in conjunction with a suitable mobile modem.

The screenshot shows the configuration page for SMS alarms. At the top, there are tabs for 'Cellular Radio', 'NTP', 'FTP', 'EMail', 'SMS', and 'Export Format'. The 'SMS' tab is active. Below the tabs, there is a section for 'active' with a checked checkbox. Underneath, there are two phone number fields: 'Phone #1: 012345 23456' and 'Phone #2: 065432 98333'. A checkbox labeled 'Phone #2 active' is checked. There are three message configuration rows. The first row has 'Message: Alarm! Sensor defect' and 'Activator: Switching Output Channel: 8'. The second row has 'Message: Alarm! Temperature threshold exceeded' and 'Activator: Switching Output Channel: 10'. The third row has an empty 'Message' field and an empty 'Activator' dropdown.

The SMS service of the Ser[LOG] supports up to 2 recipients. Their telephone numbers are entered in the fields "Phone number 1" and "Phone number 2". In order to also use the 2nd call number for sending, the checkbox "Phone number 2 active" is selected.

In the field "Message" the corresponding alarm text is entered and, in the field, "Initiator" the switching channel is selected, which triggers the sending of the SMS. See also Chapter 7 "Configuration of the switching outputs and alarms".

Note: Warnings by e-mail are preferable to warnings by SMS, because when an SMS is sent, the mobile data connection must first be terminated. This means that at this time there is no access to the server[LOG] and the device cannot operate via FTP or e-mail. From a cost point of view, it can also be cheaper to use the alarm via email instead of the SMS alarm.

7 Configuration of the switching outputs and alarms

Ser[LOG] has two built-in potential-free bistable relays. If the supply voltage of the Ser[LOG] is switched off, these relays remain in the last switched position. The activation of the relays takes place via the switching output logic of the Ser[LOG]. A total of up to 10 switching channels can be configured, of which the first two channels are permanently connected to the two relays, with channel 1 on relay output R1 and channel 2 on relay output R2.

The other switching channels can be used for external Modbus relays, for triggering email or SMS alarms. The assignment of the switching channels to the used Modbus relays is made via the "Actuators" tab. See chapter 7.4.3 for more information.

The configuration of email alarms is described in chapter 6.1.1.3 "Transmission of measured values via email / email alarm".

The configuration of SMS alarms is described in chapter 6.1.1.6 "Setting SMS alarm".

As soon as the Ser[LOG] is switched on, the relays are first initialized, then the Ser[LOG] switches the relays according to the set logic.

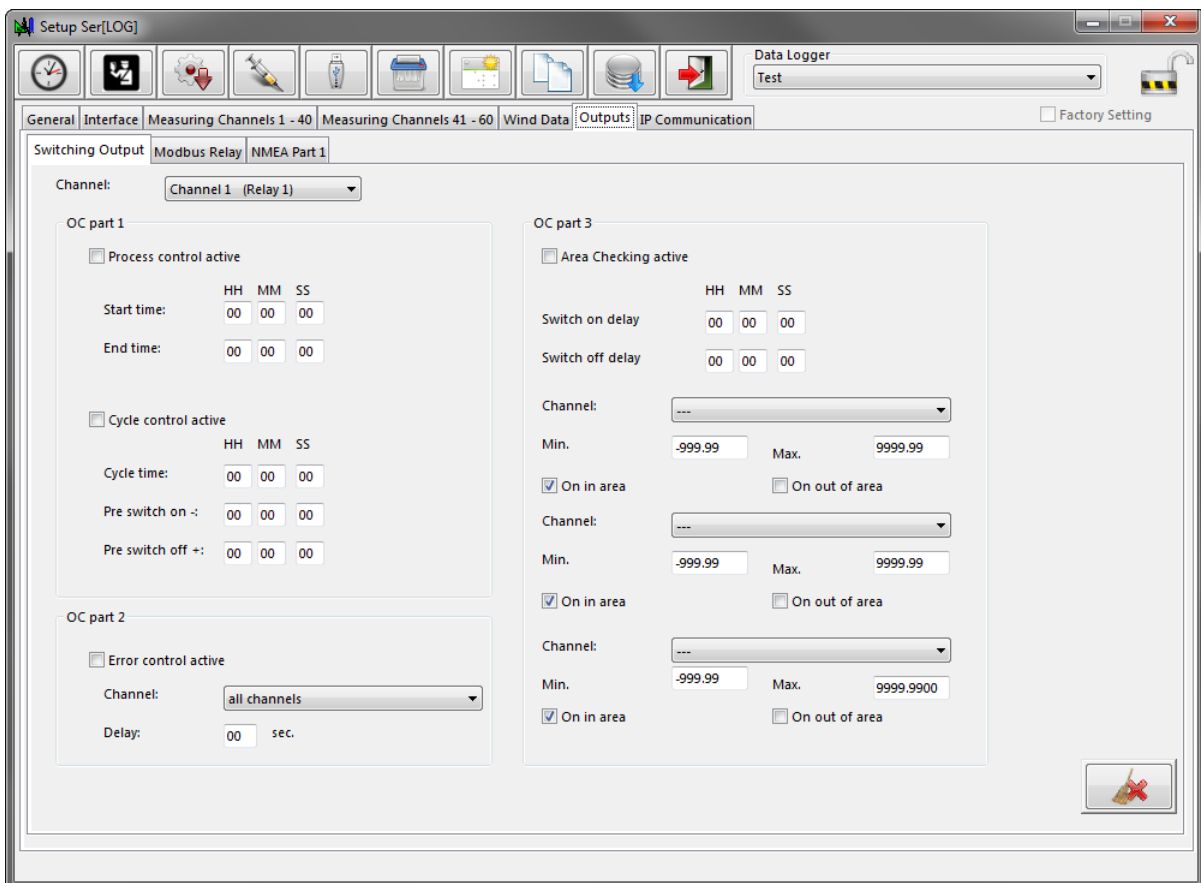

The switching channels are configured individually for each channel. The switching channel to be configured is selected in the "Channel" selection box. The following 4 control and monitoring functions are available for each switching channel:

- Process control
- Cycle control
- fault monitoring
- Area monitoring

7.1 Process control

If the process control is activated alone, the system carries out a simple on/off function according to the settings Start time / End time. The indication of the time span refers to the system time used in the Ser[LOG] (e. g. UTC, MEZ, daylight saving time). In the basic state (set condition not fulfilled) the respective relay is on contact "S0" (OFF). As soon as the Ser[LOG] is switched on, the relays are initialized and the Ser[LOG] switches the relays according to the set logic.

If the process control is combined with one of the other functions "cycle control", "error monitoring" or "range monitoring", then the process control limits this function to a certain period of time per day. Time windows can be selected in which the subordinate switching function is to take place. The process control and the other functions are linked to each other with a logical "AND".

Note: The process control is superior to the other functions when used in combination and determines the working period of the other control functions through the set time window.

The process control is activated via the checkbox "Process control active". In the fields next to the "Start time" the time in hour (HH), minute (MM) and second (SS) is set, at which the respective switching channel is set to 1 (ON).

Accordingly, the time in hour (HH), minute (MM) and second (SS) for which the respective switching channel is set to 0 (OFF) is set in the fields next to the "End time".

The set time always refers to the set local time of the Ser[LOG].

7.2 Cycle control

The cycle control provides a regular switch-on and switch-off function which is repeated at equal intervals. In the basic state (set condition not fulfilled) the respective relay is on contact "S0" (OFF). As soon as the Ser[LOG] is switched on, the relays are initialized and the Ser[LOG] switches the relays according to the set logic.

If the process control is combined with the cycle control, then the process control limits this function to a certain time period per day. Time windows can be selected in which the cycle control is to take place. The process control and cycle control are quasi-interlinked with a logical "AND".

Note: Cycle control cannot be combined with error or range monitoring!

The cycle control is activated via the checkbox "Cycle control active". In the fields next to the "Cycle time", the cycle is set in hours (HH), minutes (MM) and seconds (SS), after which the respective switching channel is set to 1 (ON). The set cycle times always refer to the full hour, starting at 00:00:00:00.

Note: The cycle control can be a simple switch-on process for a consumer or the supply voltage for a sensor, a GSM modem or other system components. When supplying sensors with power, it must be ensured that the time span set here corresponds to the average times of data acquisition.

The time before the cycle time at which the respective switching channel is set to 1 (ON) is set in the fields next to "Flow" in hours (HH), minutes (MM) and seconds (SS).

The time after the cycle time at which the respective switching channel is set to 0 (OFF) is set in the fields next to "Run-on" in hours (HH), minutes (MM) and seconds (SS).

The duration of the switching process (time period) results from the sum of pre run + post run.

It applies:

1. **Switch-on time = cycle time minus lead time span**
2. **Deactivation time = cycle time plus delay time span**
3. **Duration of the switching process = flow + run-on time**

Note: In order to exclude simultaneous switching on and off (time span = 0), the entered numerical values in the two fields "Forward" and "After-run" must not be 00:00:00 at the same time!

Example of a combination of process control and cycle control

The screenshot shows the 'Ser[LOG] konfigurieren' window. The 'Aktoren' tab is active, showing configuration for 'Kanal 1 (Relais 1)'. The interface is organized into three main sections: OC Teil 1, OC Teil 2, and OC Teil 3. OC Teil 1 includes 'Prozesssteuerung aktiv' (checked) with start time 07:00:00 and end time 17:00:00, and 'Zyklussteuerung aktiv' (checked) with a cycle time of 00:01:00, a 10-second advance ('Vorlauf'), and a 10-second follow-up ('Nachlauf'). OC Teil 2 includes 'Fehlerüberwachung aktiv' (unchecked). OC Teil 3 includes 'Bereichsüberwachung aktiv' (unchecked) and three channel settings, each with 'ON innerhalb' (checked) and 'ON außerhalb' (unchecked). The channel settings include dropdown menus for 'Kanal', 'Minimum' (-999.99), and 'Maximum' (9999.99). The window title is 'Ser[LOG] konfigurieren' and the data logger is set to '2002_SerLog_SCHWARZ'.

In the example above, relay 1 switches on every minute for 20 seconds (10 seconds advance + 10 seconds follow-up) from 7:00 to 17:00.

7.3 Error monitoring

Fault monitoring is used to trigger a switching process in the event of sensor failures, e. g. wire breakage or exceeding the measuring range. In the basic state (set condition not fulfilled) the respective relay is on contact "S0" (OFF). As soon as the Ser[LOG] is switched on, the relays are initialized and the Ser[LOG] switches the relays according to the set logic. The error monitoring can be set for one sensor or for all sensors together.

Error monitoring is activated via the checkbox "Error monitoring active". In the "Measurement channel" selection field, the sensor value to be monitored (measurement channel) can be selected or the error monitoring for "all channels" (measurement channels) can be set.

The "Delay" field is used to set the minimum time for which an error must be present before the output is switched. The delay time can be set in the range from 0 to 60 seconds to suppress any errors that occur only briefly if necessary.

Note: Error monitoring can be combined with process control and area monitoring. A simultaneous cycle control together with error monitoring at the same switching output is not possible!

The screenshot displays the 'Setup Ser[LOG]' software interface, specifically the 'Outputs' tab for 'Channel 1 (Relay 1)'. The interface is organized into three main sections: OC part 1, OC part 2, and OC part 3. OC part 1 includes checkboxes for 'Process control active' and 'Cycle control active', along with time selection fields for start/end times and cycle/pre-switch times. OC part 2 features a checked 'Error control active' checkbox, a 'Channel' dropdown menu set to 'all channels', and a 'Delay' field set to 10 seconds. OC part 3 contains 'Area Checking active' checkboxes, 'Switch on delay' and 'Switch off delay' time fields, and three channel-specific monitoring blocks, each with 'On in area' and 'On out of area' checkboxes. The top of the window shows various icons and a 'Data Logger' dropdown menu set to 'Test'.

7.4 Area monitoring

The range monitoring is used to monitor limit values (MIN/MAX) while simultaneously taking into account the data from up to three different sensors. By means of additional selection boxes "ON within" and "ON outside", it can be determined in which range the switching function is to take place. In the basic state (set condition not fulfilled) the respective relay is on contact "S0" (OFF). As soon as the Ser[LOG] is switched on, the relays are initialized and the Ser[LOG] switches the relays according to the set logic.

Note: Area monitoring cannot be combined with cycle control! Area monitoring can be combined with process control and error monitoring.

7.4.1 Simple area monitoring (OR operation)

Up to 3 sensors can be selected for range monitoring per switching output.

If different sensors (1 to max. 3) are selected for range checking, the sensor data is linked via a logical "OR operation", i. e. a switching process takes place when a limit value condition is reached.

The area monitoring is activated via the checkbox "Area monitoring active". The time in hours (HH), minutes (MM) and seconds (SS) for which the event (area violation) must be present is set in the fields next to the "On delay" before the respective switching channel is set to 1 (ON).

Correspondingly, in the fields next to the "Off-delay end", the time in hours (HH), minutes (MM) and seconds (SS) for which the event (range violation) is no longer present is set before the respective switching channel is reset to 0 (OFF) again.

In the "Measurement channel" selection box, the sensor value (measurement channel) to be monitored is selected.

The limit values for range monitoring are entered in the "Minimum" and "Maximum" fields below them.

Note: The minimum numerical value must always be smaller than the maximum numerical value!

The switching logic can be set via the checkboxes "ON within" and "ON outside".

Either the checkbox "ON within" can be activated and thus a warning can be issued as soon as the measured value is found within the range configured with "Minimum" and "Maximum" or the checkbox "ON outside", whereby a warning occurs as soon as the measured value is outside the configured range.

OC part 3

Area Checking active

Switch on delay: HH MM SS: 00 00 30

Switch off delay: 00 01 00

Channel: S03 E_08090.231010_Temperature PT100

Min. -999.99 Max. 25.00

On in area On out of area

Channel: S07 E_16103.000000_Radiation

Min. -999.99 Max. 700

On in area On out of area

Channel: ---

Min. -999.99 Max. 9999.9900

On in area On out of area

Example - simple area monitoring

The relay signals that the temperature limit value (S 03) has been exceeded when the set maximum limit value is exceeded: 25 °C

OR

of global radiation (S 06) when the set maximum limit value is exceeded: 700 W/m².

with a switch-on delay of 30 seconds or a switch-off delay of one minute.

7.4.2 Group-related area monitoring (AND operation)

The configuration of the group-related range monitoring is equivalent to the configuration of the "simple range monitoring" described in chapter 7.4.1, however, a logical "AND operation" for 2 measuring channels can be realized by a special selection of the measuring channels. To do this, the same measuring channel must be selected for measurement channels 2 and 3.

This function can be used, for example, to implement wind direction dependent wind speed warnings or frost warnings.

For the second measured value in the selection fields "Measuring channel 2" and "Measuring channel 3", 1 or 2 value ranges can be entered.

If only 1 value range is to be monitored, the same values must be entered for "Measuring channel 2" and "Measuring channel 3" at "Minimum" and "Maximum" respectively. (See example "Area monitoring wind speed AND wind direction (1 segment)" below.

If 2 value ranges are to be monitored, one value range must be entered for "Measuring channel 2" at "Minimum" and "Maximum" and for "Measuring channel 3" the other value range must be entered at "Minimum" and "Maximum". (See example "Area monitoring wind speed AND wind direction (2 segments)" below.

This assignment results in the following switching condition:

The switching process is triggered when the limit values of measuring channel 1 AND measuring channel 2 OR measuring channel 3 are exceeded.

OC part 3
 Area Checking active
HH MM SS
Switch on delay 00 00 00
Switch off delay 00 00 00
Channel: S10_E_14522.100040_WS_Pro_4-20_75m/
Min. 0 Max. 7.5
 On in area On out of area
Channel: S11_E_14521.100040_WD_Prof_4-20mA
Min. 45 Max. 335
 On in area On out of area
Channel: S11_E_14521.100040_WD_Prof_4-20mA
Min. 45 Max. 335.0000
 On in area On out of area

Example - Area monitoring Wind speed and wind direction (1 segment)

The relay signals that the wind speed limit value (S05) has been exceeded only in a 45 to 315 degree segment when the wind direction is northbound.

Note: For only one segment of the wind direction, the same entries must be made in both fields.

Note: The segment from "45 to 315 degrees around north" goes above the zero point of the full circle. Since the minimum numerical value must always be smaller than the maximum numerical value, the switching logic "ON outside" must be set here.

OC part 3
 Area Checking active
HH MM SS
Switch on delay 00 00 00
Switch off delay 00 00 00
Channel: S10_E_14522.100040_WS_Pro_4-20_75m/
Min. 0 Max. 7.5
 On in area On out of area
Channel: S11_E_14521.100040_WD_Prof_4-20mA
Min. 45 Max. 335
 On in area On out of area
Channel: S11_E_14521.100040_WD_Prof_4-20mA
Min. 135 Max. 225
 On in area On out of area

Example - Area monitoring Wind speed and wind direction (2 segments)

The relay signals that the wind speed limit value (S05) has been exceeded only for wind directions around north or south in segments of 315 to 45 degrees or 135 to 225 degrees.

Note: The segment from "45 to 315 degrees around north" goes above the zero point of the full circle. Since the minimum numerical value must always be smaller than the maximum numerical value, the switching logic "ON outside" must be set here. For the 135 to 225 degree segment, however, the switching logic must be set to "ON within".

7.5 Modbus relay

The Ser[LOG] can be extended with up to 10 Modbus relays. These Modbus relays can be assigned to the 10 switching channels.

Note: Switching channels 1 and 2 are permanently connected to relay outputs R1 and R2 of the Ser[LOG] but can also be assigned to a Modbus relay in addition.

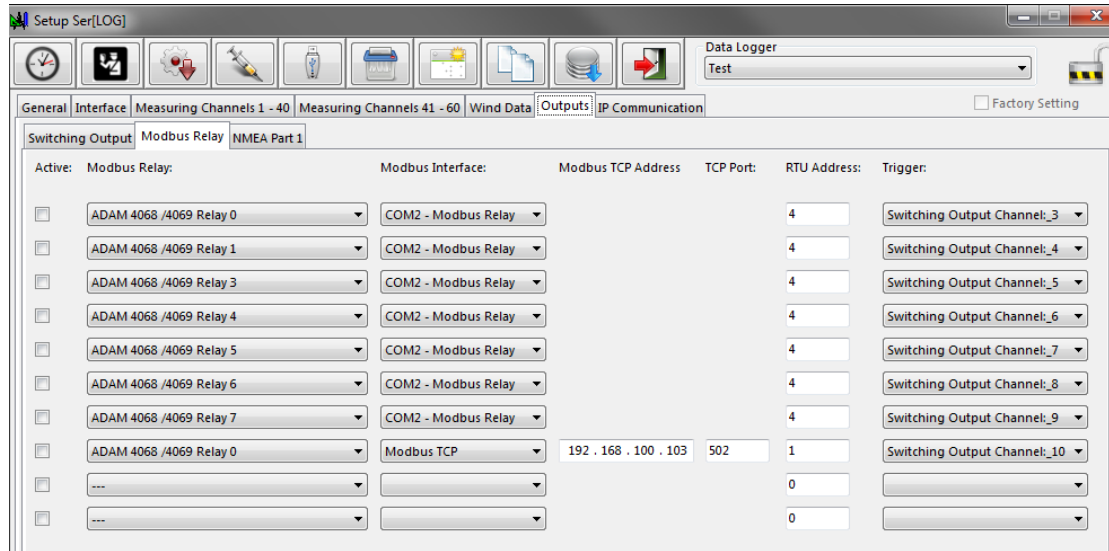

Relays with "Modbus RTU" must not be configured on a "Modbus sensor bus", for which a separate bus (Modbus actuator bus) must be configured on a COM interface.

For this purpose, the standard: "RS485" and the protocol: "Modbus relay" must be selected in the



Ser[LOG] configuration under the register selection "Interface" for the COM interface used.

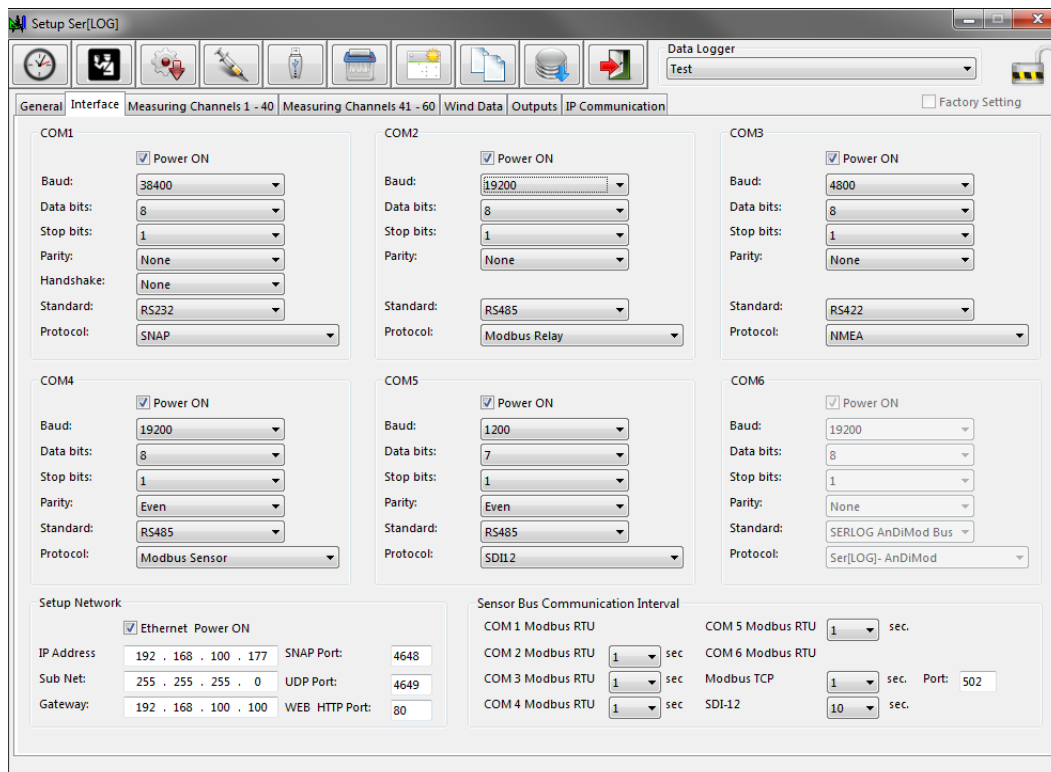

Up to 10 Modbus relays can be defined. By activating the checkbox "Active" the respective definition line is armed.

In the selection box of the "Modbus Relay" column, a relay from the Modbus relay database is loaded. Similar to the sensor database, own Modbus relays can also be defined. Please refer to the following chapter 7.4.4.

In the selection box of the "Modbus Interface" column, the interface on which the Modbus relay is located is selected. Available for selection:

- COM X - Modbus relay (X = each configured COM interface)
- Modbus TCP

The device address of the respective Modbus relay must be entered in the field of the column "RTU address".

If "Modbus TCP" is selected as the "Modbus interface", the fields "Modbus TCP address" and "TCP port" are also displayed, which must be filled in accordingly. The TCP port is usually set to its default port 502.

The Modbus relay is assigned to a switching output via the selection box in the "Trigger" column. If this switching output trips, the corresponding Modbus relay is switched. Multiple use of a switching output is possible.

7.5.1 Definition of new Modbus relays



Pressing the button "Define Modbus relay" in the main selection opens the "Settings Modbus relay settings" window.

Like Modbus sensors, Modbus relays are considered as single channels and not as Modbus devices. A separate definition is created for each relay.

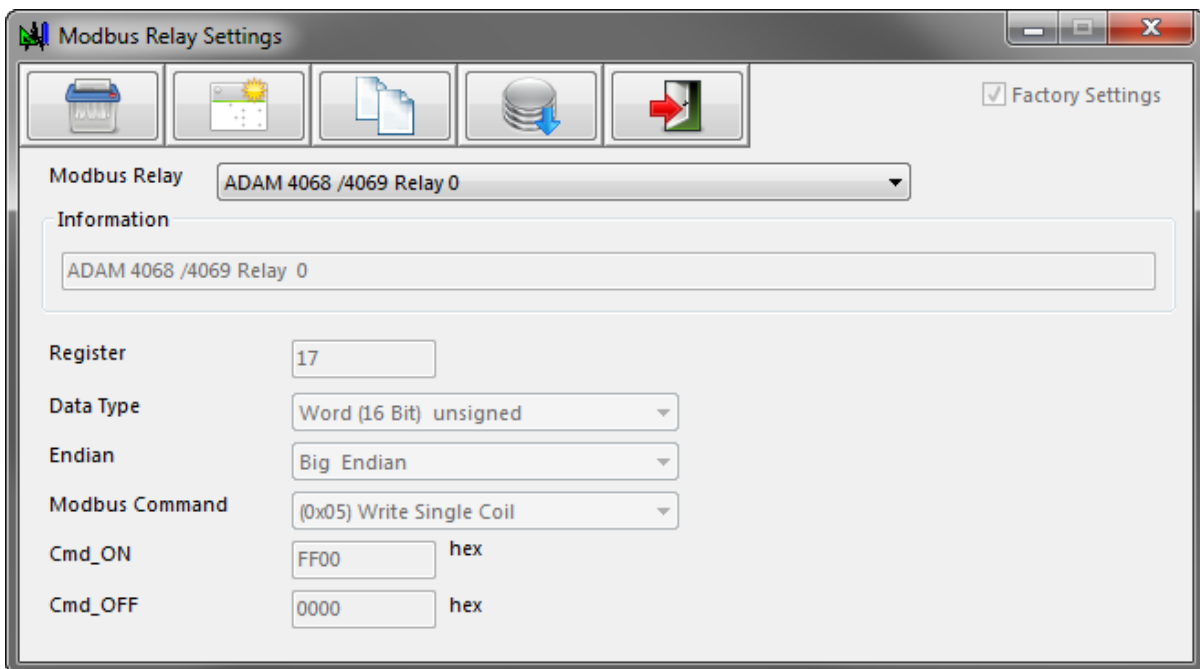

To create a new Modbus relay, click on the "New Data Set" button. The Ser[LOG]-Commander then switches to a "new" definition window. In this mode, the "Modbus Relay" selection box is an input field in which you can enter the name of the Modbus relay.

In the "Information" field you can enter a descriptive text for the Modbus relay. The register of the Modbus relay to be controlled must be entered as a decimal number in the "Register" field.

The "Data type" of the register is selected in the selection field:

- Integer (16Bit) signed
- Word (16Bit) unsigned
- Long Integer (32Bit) signed
- Double Word (32Bit) unsigned

The standard bit sequence for Modbus is "Big Endian", but there are also devices that use "Little Endian". The respective bit sequence can be selected in the field "Endian".

Ser[LOG] currently offers only Modbus command 0x05 for controlling Modbus relays. The value used to switch on the relay is entered in the Cmd_ON field, the value used to turn off the relay is entered in the Cmd_OFF field.

8 Configuration of wind data processing



In the Ser[LOG] configuration under the register selection "Wind data", Ser[LOG] offers the possibility to calculate moving average values for up to 2 pairs of wind sensors.

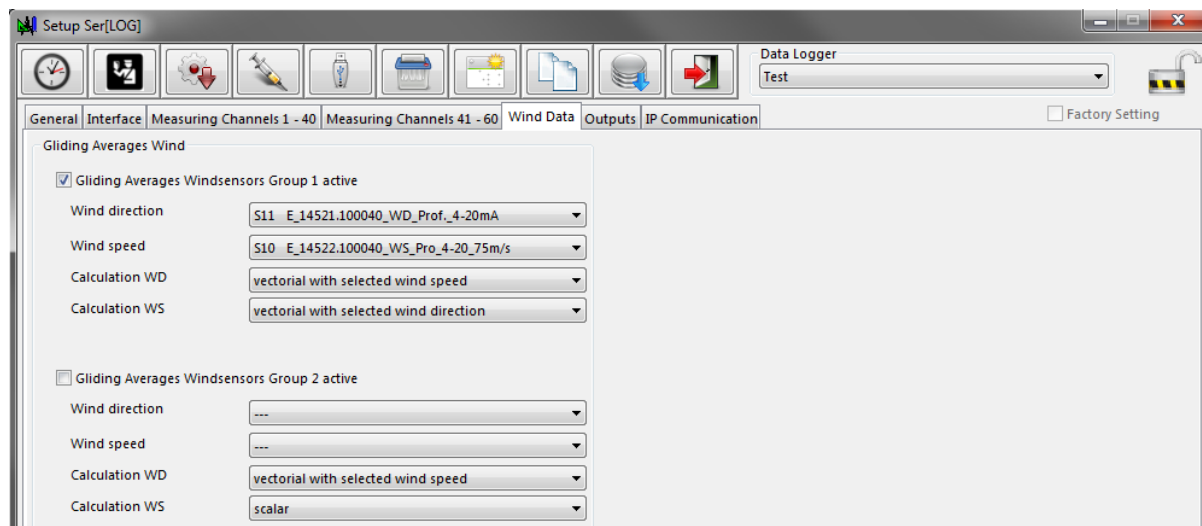

The calculation of the moving wind data for each sensor pair is activated via the checkbox "Moving wind speed sensor pair[...] active".

In the "Wind direction" field, select the wind direction sensor previously created in the sensor configuration, which is to be linked to the wind speed sensor selected in the "Wind speed" selection box.

In the field "Calculation type WR", the calculation type for the averaging of the wind direction measurement is selected for the wind direction sensor:

vectorial with selected WG

Vector averaging with linked wind speed measurement.

vectorial with WG = 1 m/s

Vector averaging with a unit wind speed of 1 m/sec.

In the field "Calculation type WG" the calculation method for the calculation of the averaging of the wind speed measurement is selected for the wind speed sensor:

vectorial with selected WR

Vector averaging with the linked wind direction measurement.

scalar

Simple (scalar) averaging of the wind speed measurement, independent of the wind direction.

It has been proven to calculate the wind direction vectorially with a virtual speed of 1 m/s and to consider the wind speed as a scalar value. The data calculated here can be displayed with the LAMBRECHT application MeteoWare-CS4.

9 SDI-12 Dialogue - Tool





The Ser[LOG]-Commander provides additional tools via the button . Among other things, this collection offers a tool for direct dialogue with SDI-12 devices.

In the "Station" field, first select the Ser[LOG] via which the SDI-12 dialog is to be executed.

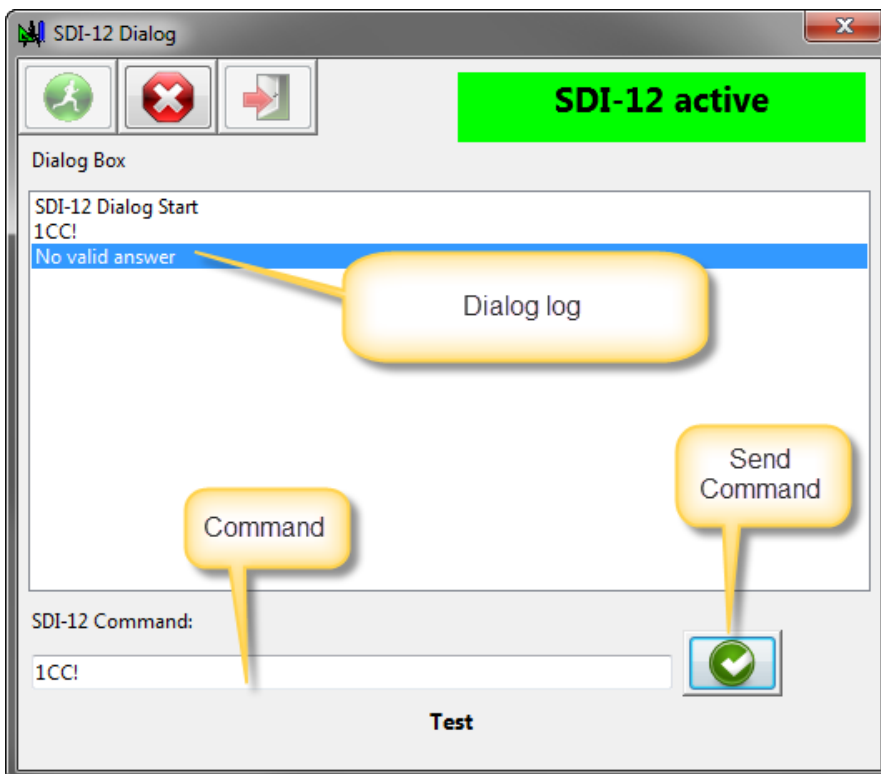

The SDI-12 dialog is started with the button .



The dialog is started by . The status display then indicates that SDI-12 is active.

Important note: The SDI-12 connection for data acquisition is switched off during this time!



In the field "Command input" a SDI-12 command can be entered and sent by

The command and the response to it are displayed in the dialog box.



The SDI-12 dialog is terminated by and the SDI-12 connection for measured value acquisition is switched on again!

10 Firmware Update

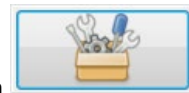

The Ser[LOG]-Commander provides additional tools via the button . This collection provides a tool for updating the Ser[LOG] firmware under the "Firmware Update" tab.

In the selection field "Station" select the name of the Ser[LOG] whose firmware is to be updated.

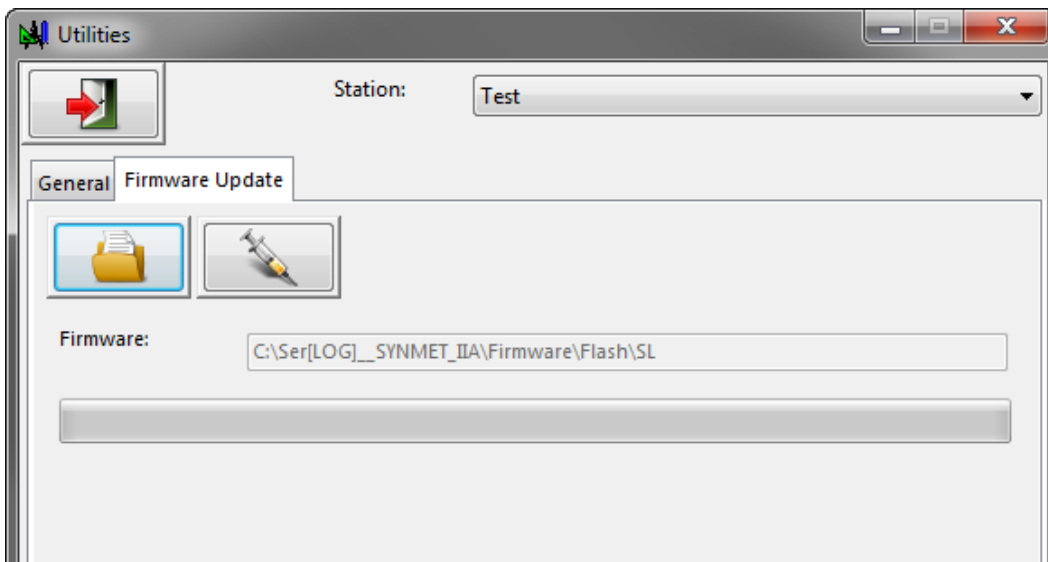

Pressing the button opens a Windows file dialog for selecting the firmware to be loaded.



The button starts the firmware update, and the firmware is transferred to the device. First only the file transfer takes place, then the Ser[LOG] checks the firmware for validity and integrity and only then the firmware is written into the flash memory of the logger.

Note: Please note that the Ser[LOG] must be connected to the PC via the interface configured for the respective station. If necessary, adjust the interface in the "Ser[LOG] configuration". See also chapter 5.3.1.1, chapter 5.3.1.2 and chapter 5.3.4.

Malfunctions or damaged firmware cannot affect the Ser[LOG]. If no valid, valid firmware is delivered, the Ser[LOG] ignores the update attempt and continues to work with its existing firmware.

11 Other functions - USB stick readout

As described in chapter 3.2, data can be exported via the USB interface directly on the Ser[LOG] with a USB memory stick. The configuration of the Ser[LOG] is always saved with the measured values on the USB stick. This configuration can either be loaded directly via the USB stick to another Ser[LOG] or read out together with the stored measured values using the Ser[LOG]-Commander.



To do this, click on the  button to access a menu that can be used to access other functions, some of which are rarely used. See also chapter 4.8.

One of these functions "Read USB stick" reads the configuration from the USB stick and, if it does not yet exist, creates it automatically in the station database of the Ser[LOG]-Commander.

At the same time, the measured values stored on the USB stick are read out and saved in a CSV file. This enables fast data export if the stored measured values have been collected manually.

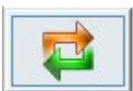

The small application prompts you to insert the USB stick into the PC. By pressing the button  "OK" the detected removable drives are displayed and can be selected in the field "removable drives". If the correct drive is not included or if the USB stick has not yet been inserted, the drive list can be

updated by clicking the  button.

Pressing the "OK" button  again loads the data from the USB stick!

Important note: The application asks after downloading the data whether the USB stick should be deleted! It is therefore recommended to use a USB stick that is only intended for data export and does not contain any other important data!

12 Managing the safety settings

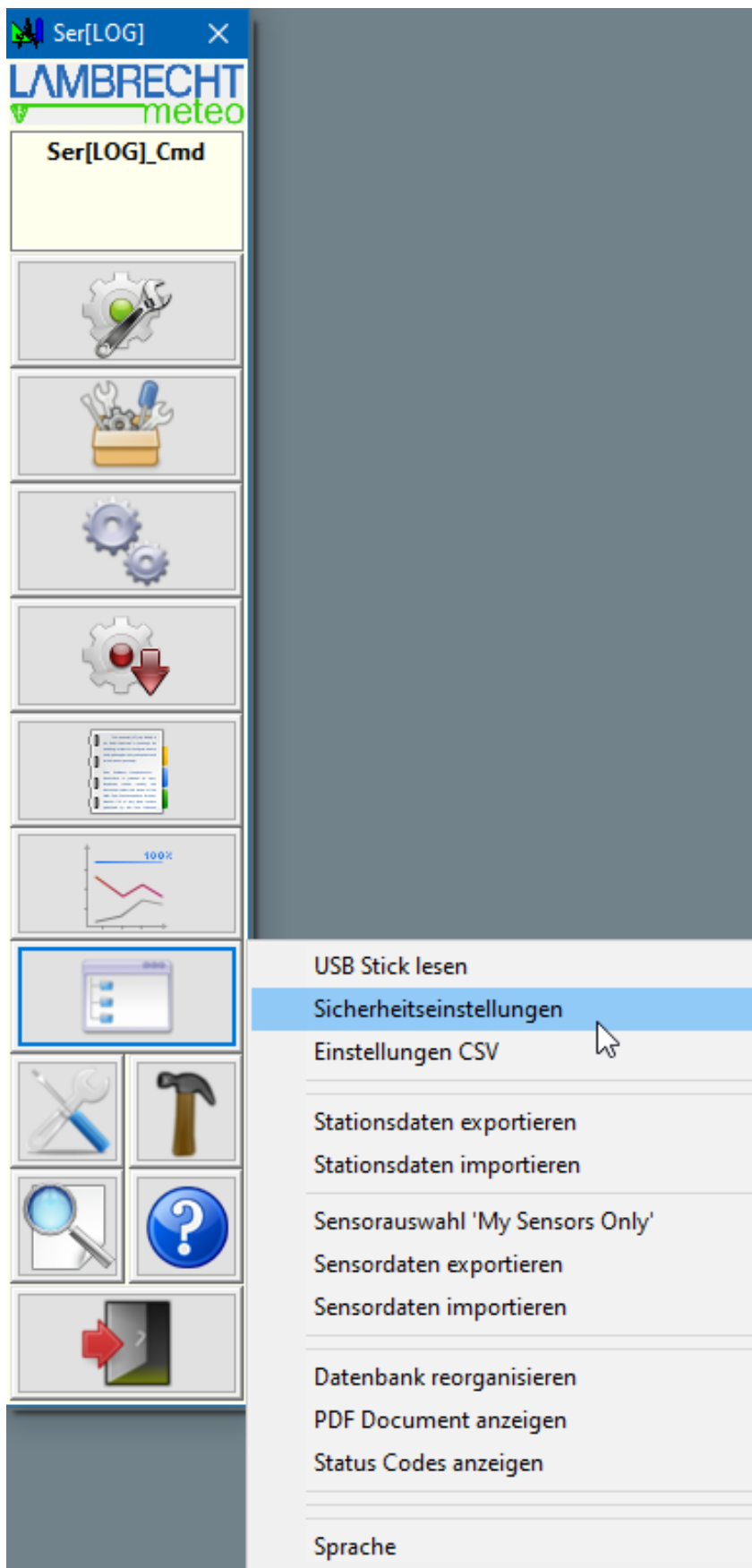

The **Security Settings** screen is only accessible to the **Administrator** user.

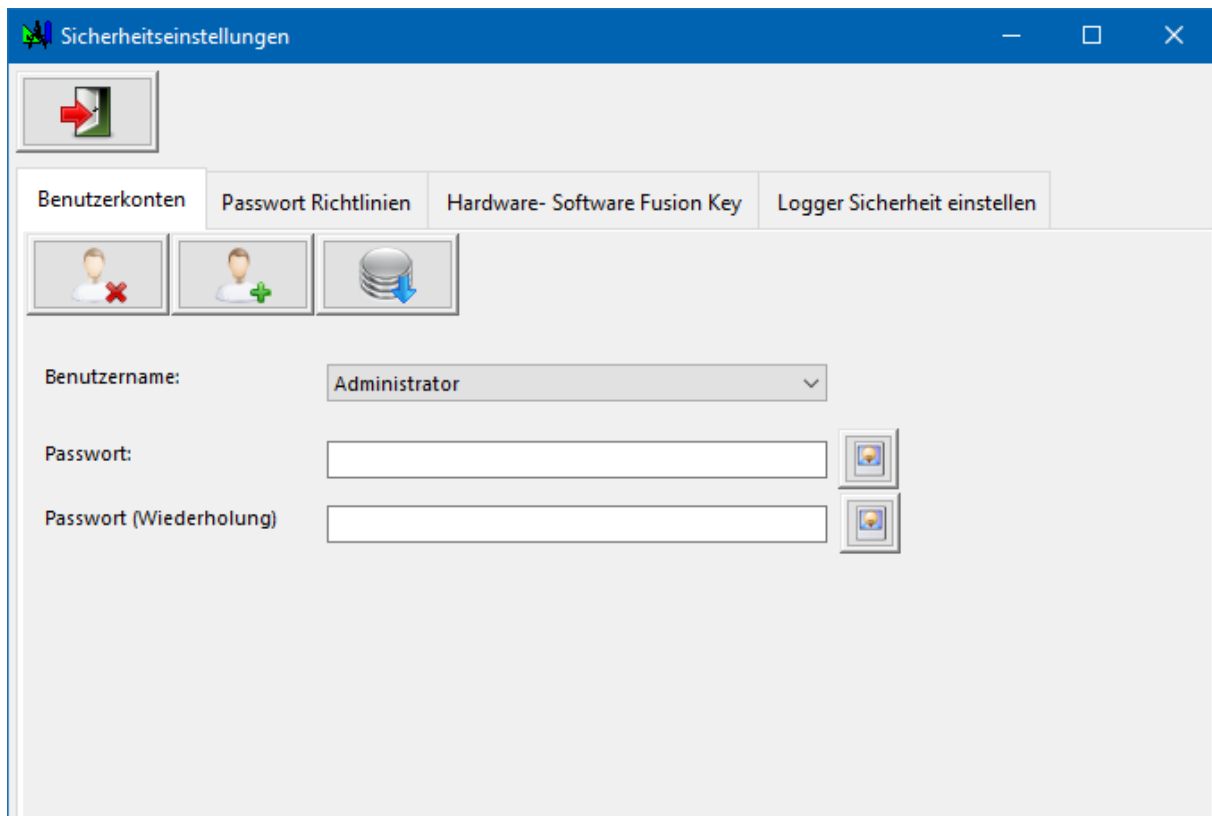

12.1 Register user accounts

User accounts can be created or deleted here; passwords can be overwritten without knowing the current password.



creates a new user account



deletes an existing user account



saves the changes in this register



ends the function and closes the mask



displays the input in the field while holding down the left mouse button

12.2 Register “Password guidelines“

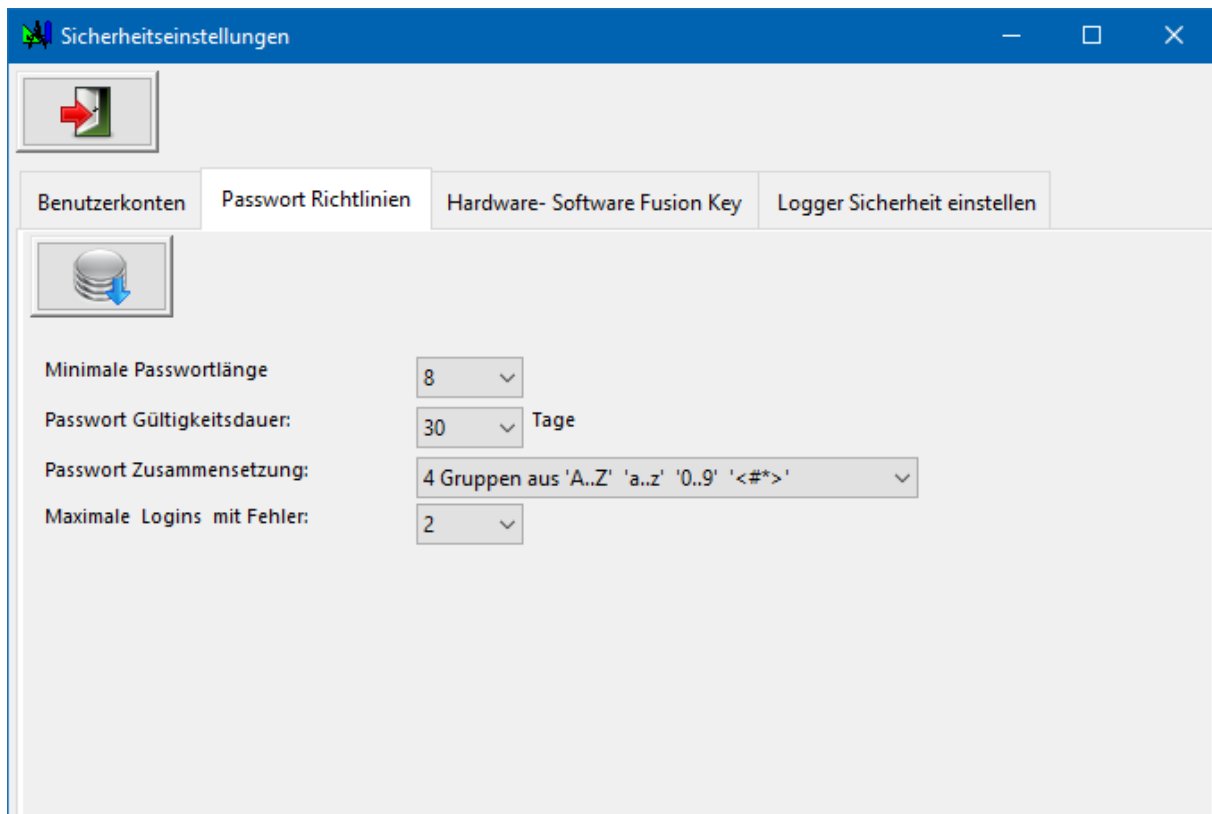

In the factory default setting, only a primitive password is required.

For higher requirements Lambrecht recommends changing the settings as suggested here. When entering the password, the system then checks for the structure defined here.

Attention! Change the administrator password immediately according to these settings.



saves the changes in this register



ends the function and closes the mask

Attention!

The following two registers describe the activation of a protection mechanism that merges Ser[LOG] and the application software (Ser[LOG]_Cmd and MeteoWare_CS_4) into one unit. Only programs and loggers in which the code for the fusion of software and hardware is stored can then communicate with each other. The advantage is that this code is entered in the programs only once by the administrator and is subsequently no longer visible or retrievable. Even legitimate users of the software cannot see or change it. It is not transferable from one computer to another (copy all files of the software), because it checks computer internal identifiers and destroys itself if necessary. On each PC on which Ser[LOG]_Cmd or MeteoWare_CS_4 is to be used; the administrator must re-enter the code.

At the same time, access to the logger control panel is blocked and can only be unlocked by entering a 12-digit numeric code.

This form of access protection to the data loggers is particularly advantageous for measuring networks, as it allows all loggers to be protected without having to assign individual passwords, which are usually

identical and, according to Lambrecht's experience, follow the factory default almost 100% of the time. Locking the operating unit prevents unauthorized persons from making direct changes to the logger.

12.3 Register Hardware-Software Fusion Key

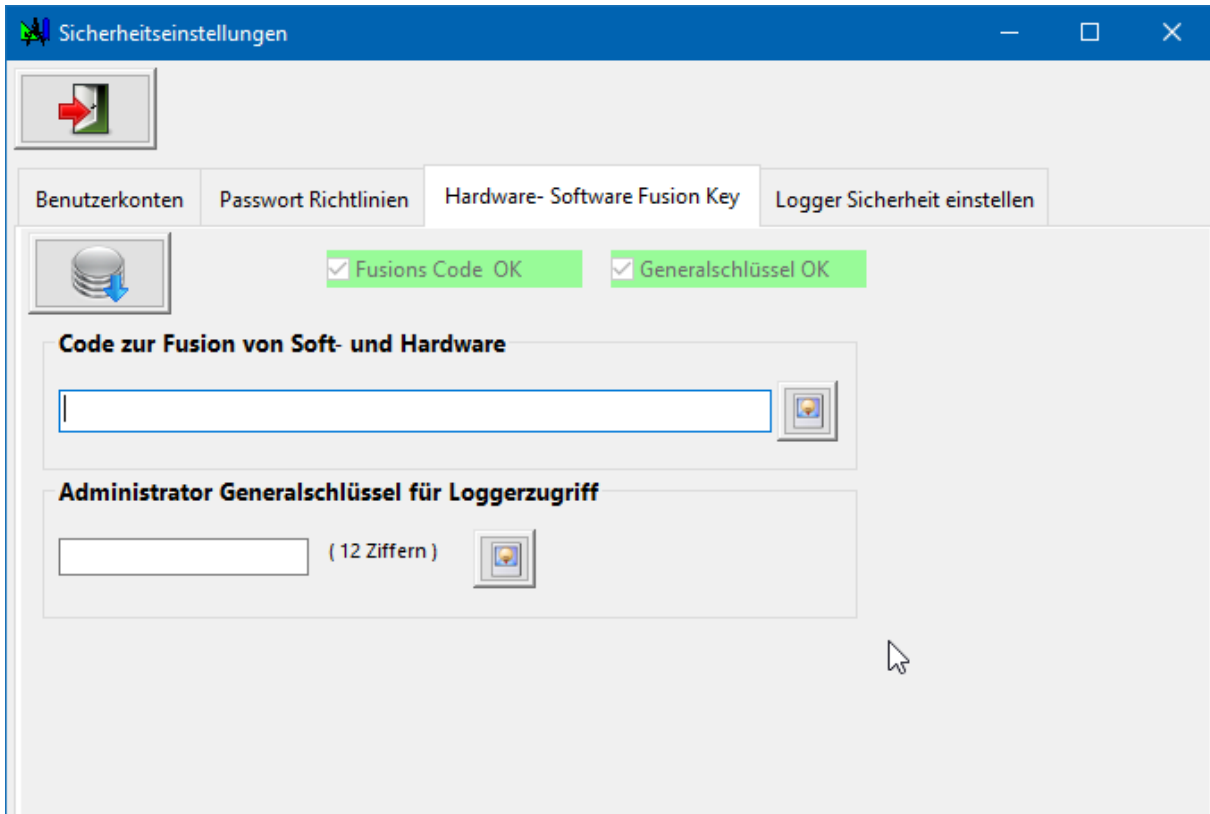

The key for fusion of software and hardware is entered in the corresponding field. A 12-digit numerical code is entered in the Administrator master key field, which can be used to unlock the service unit on the logger if the logger has been protected. This key serves as a backup if the user key has been changed and forgotten.

LAMBRECHT meteo recommends:

Make a note of these two keys and keep them in a safe place. Lost keys can only be reset by LAMBRECHT meteo.

If the fusion code and master key have already been entered, the two check boxes at the top of the tab are highlighted in green.



displays the input in the field while holding down the left mouse button



saves the changes in this register



ends the function and closes the screen

12.4 Setting the logger safety register

Any communication with the data logger performed under this tab is done via **Lambrecht Service Port** (USB).

Query the current security status:

Select the interface "Lambrecht Service Port".



retrieves the safety setting from the Ser[LOG]

There is no safety setting so far

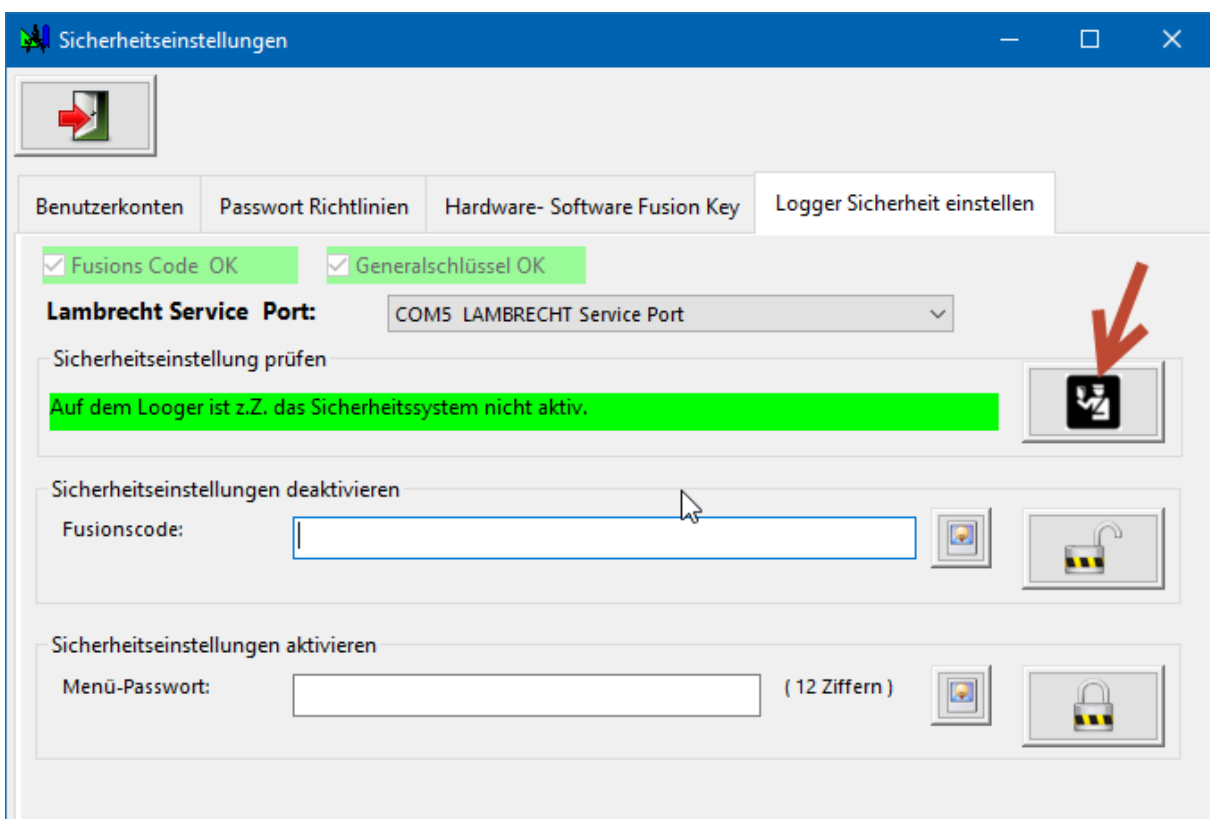

The logger is protected and is not yet ready for communication.

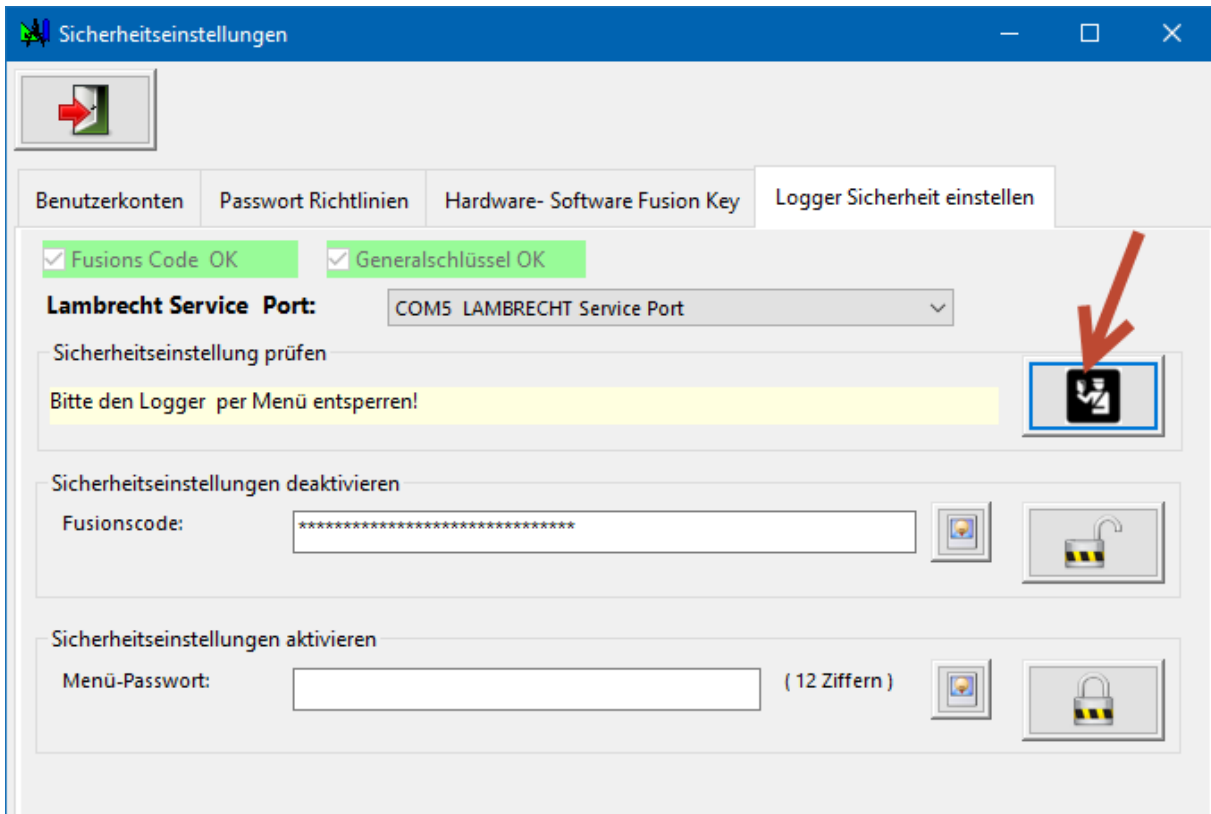

After the logger operating unit has been enabled, the check can be continued.

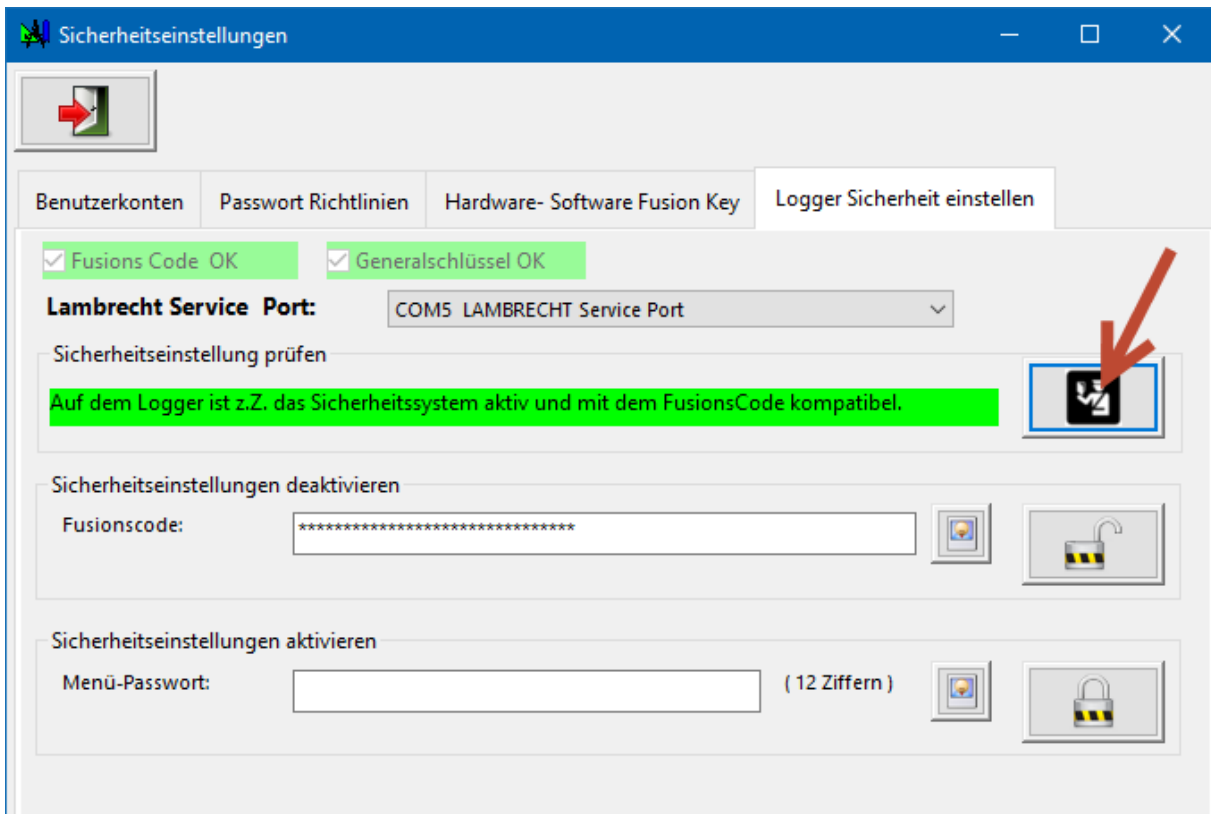

In this case, the logger is protected.

If the logger has an active protection that does not match the current fusion code, please enter the correct code in the Hardware-Software Fusion Key tab and retrieve the security settings again. If this issue still appears, please contact LAMBRECHT meteo.

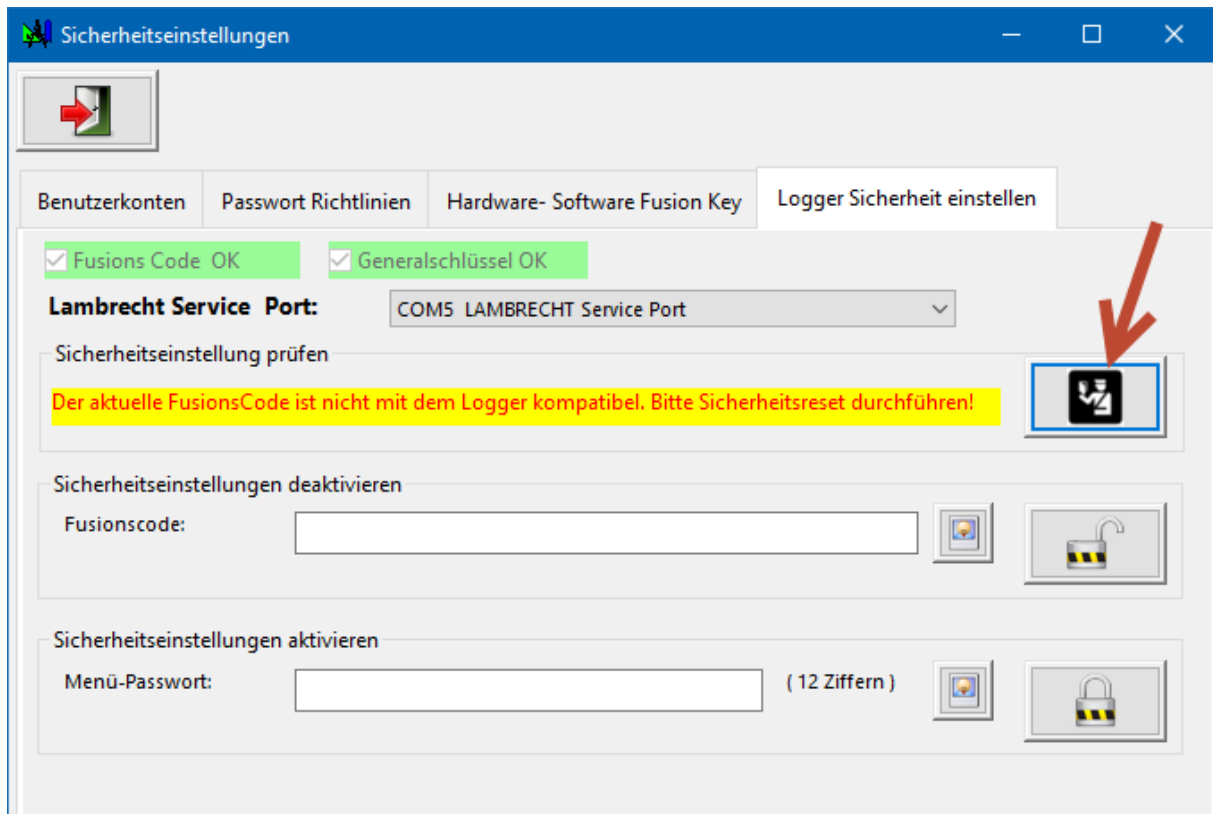

12.5 Activating the logger safety

In the Menu password field, enter a 12-digit code that the user can use to activate the operating unit of the logger in future



sets the safety settings in the logger

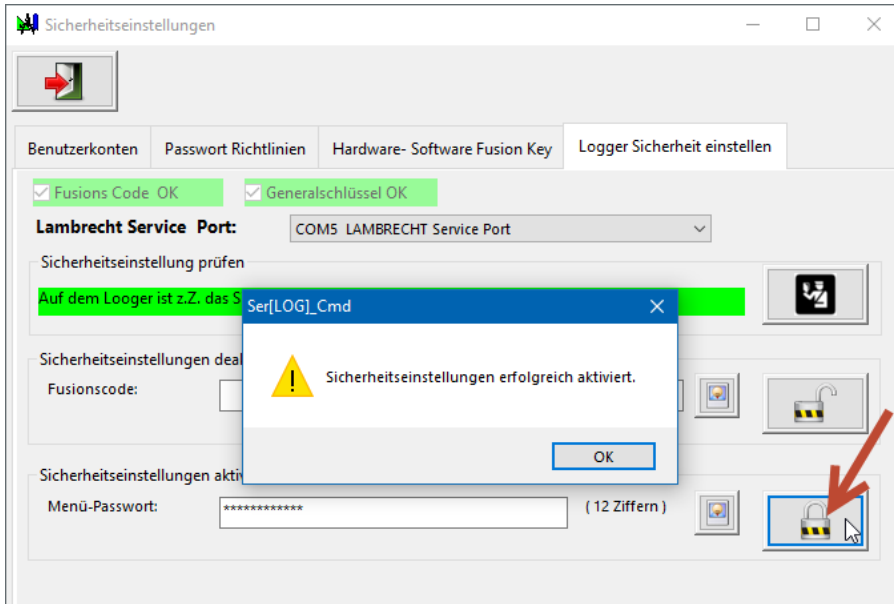

12.6 Deactivating the safety settings

Only if the retrieval of the security settings was successful and the set fusion code is identical to the current fusion code, the administrator can deactivate the security settings.

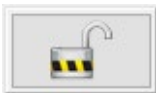

deactivates the security setting

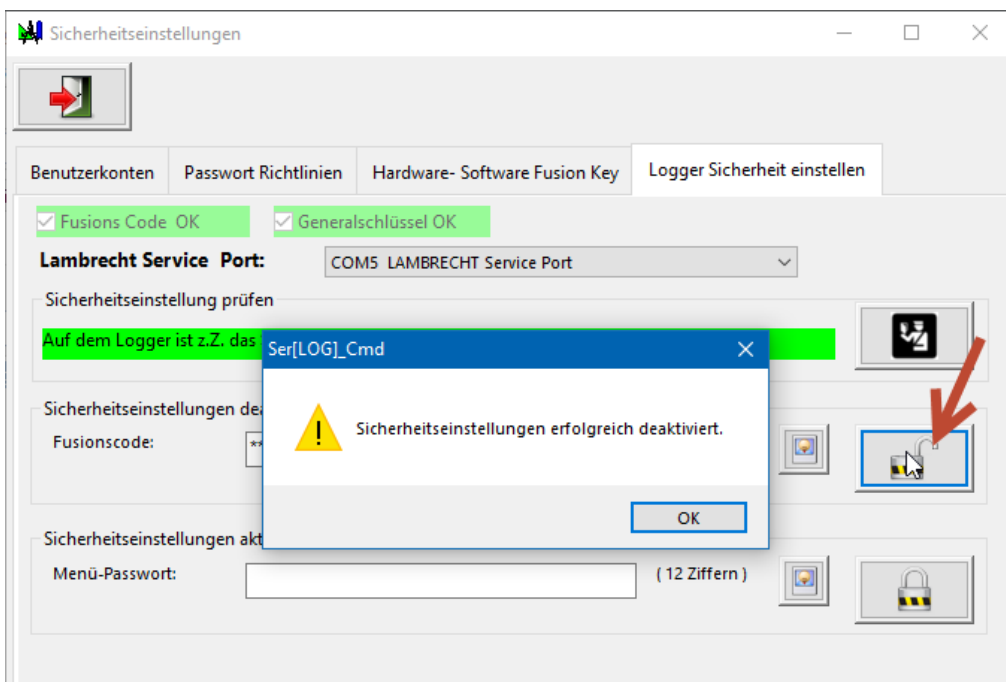

13 Connection diagrams

13.1 Overview - Terminal assignment Ser[LOG]Plus

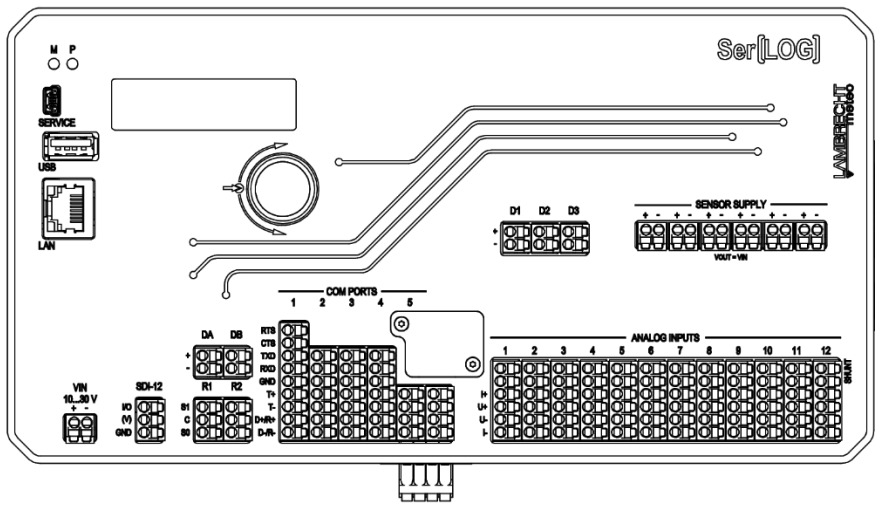

COM PORTS

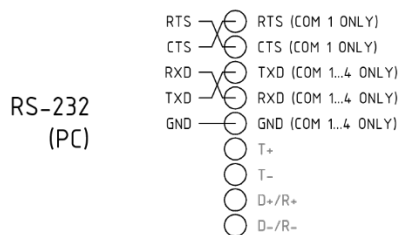
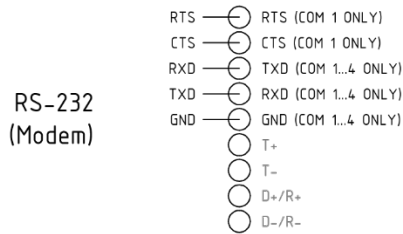
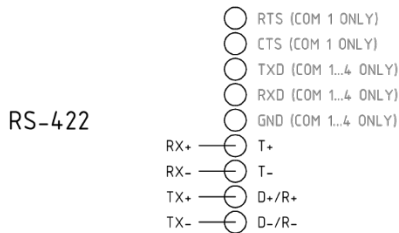
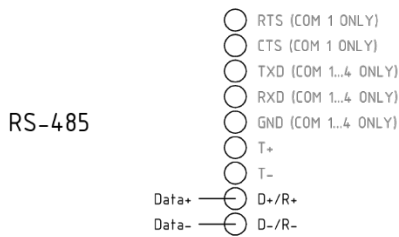

ANALOG INPUTS

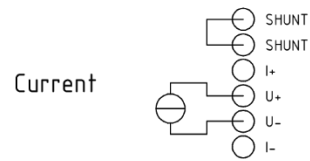
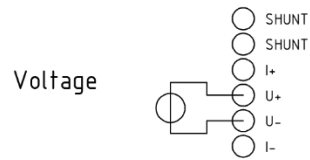
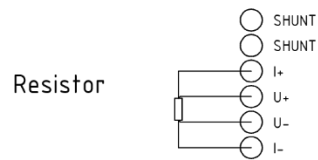

DIGITAL



ANALOG INPUTS

1...12

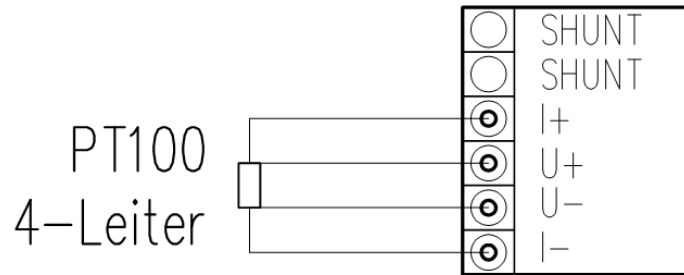

ANALOG INPUTS

1...12

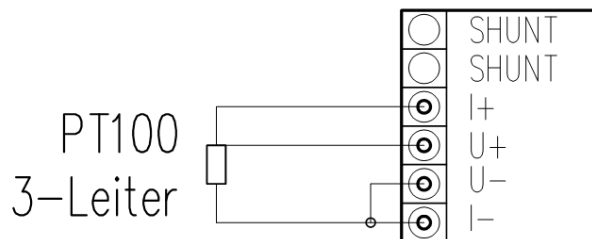

ANALOG INPUTS

1...12

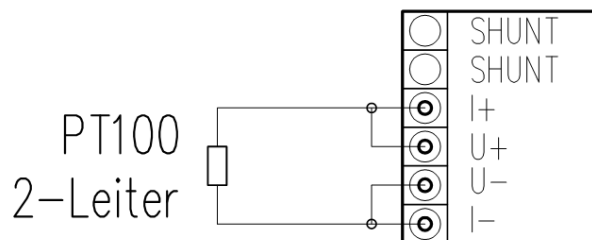

00.15184.000000

rain[e]

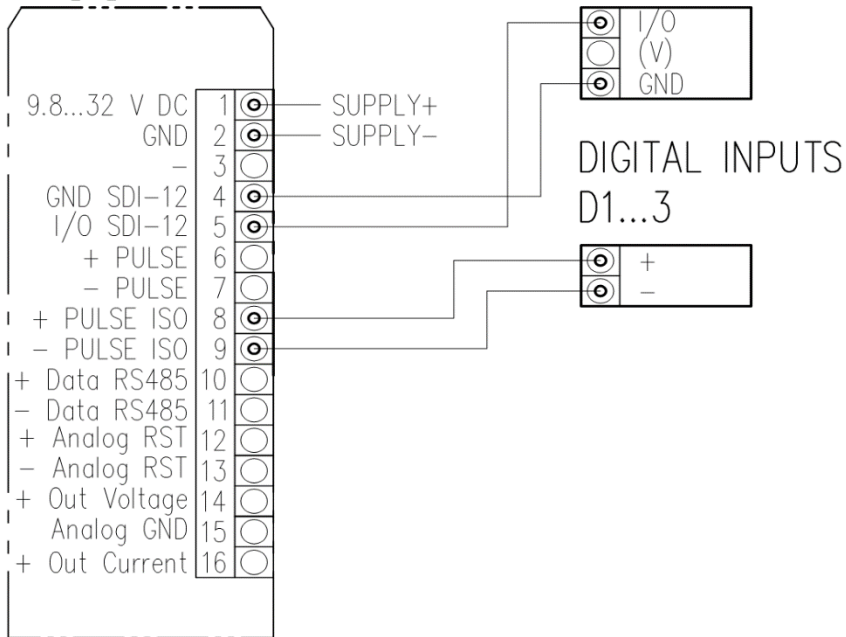

00.15188.002000

PRECIPITATION

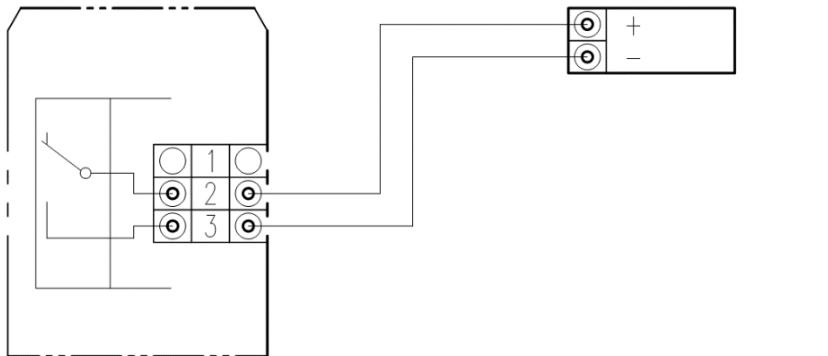

00.16103.100000

PYRANOMETER

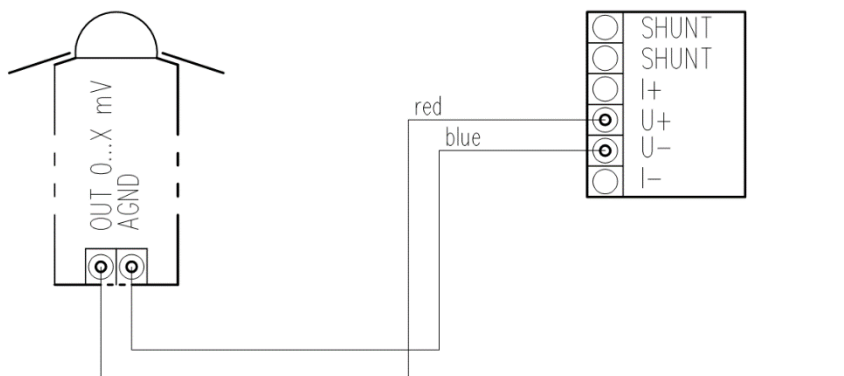

BAROMETER
ANALOG

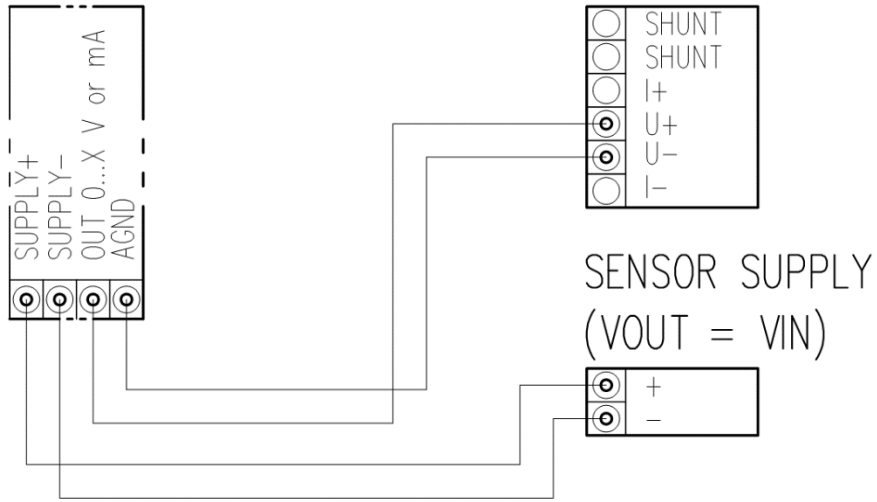

LEAF WETNESS
ANALOG

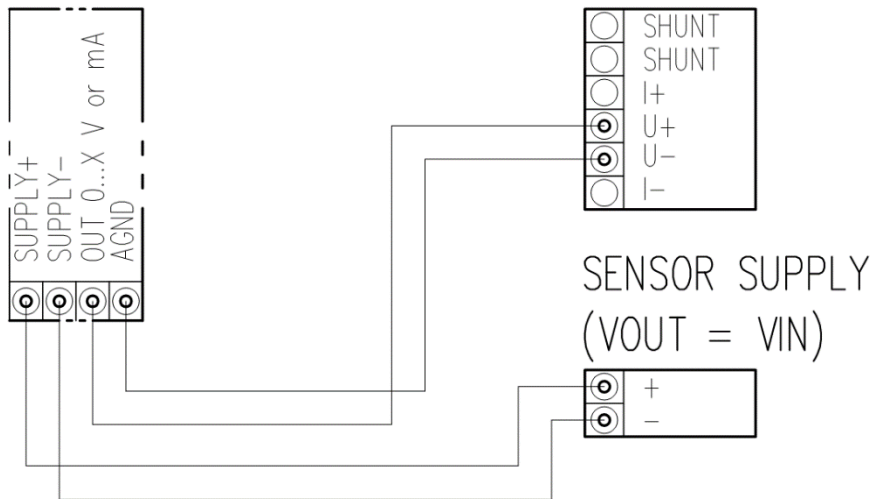

HUMIDITY-TEMPERATURE
ANALOG VOLTAGE

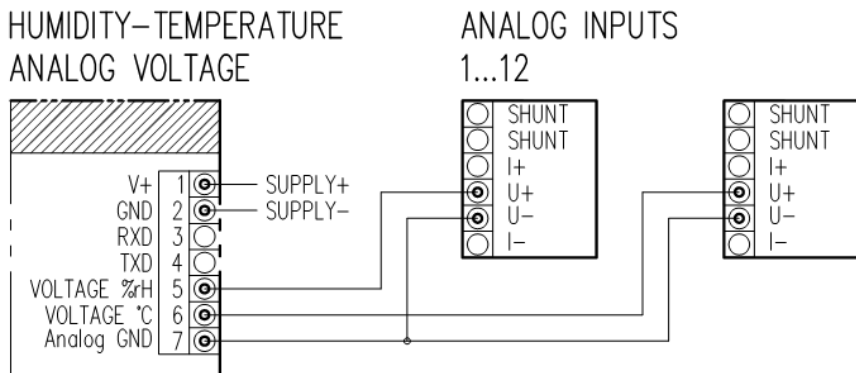

PRECIPITATION
SDI-12 & PULSE

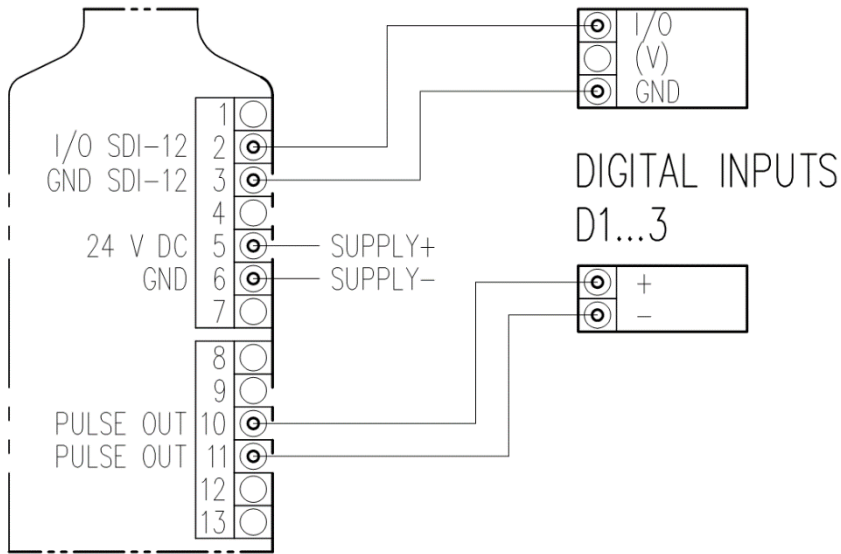

WIND SPEED
OPEN COLLECTOR

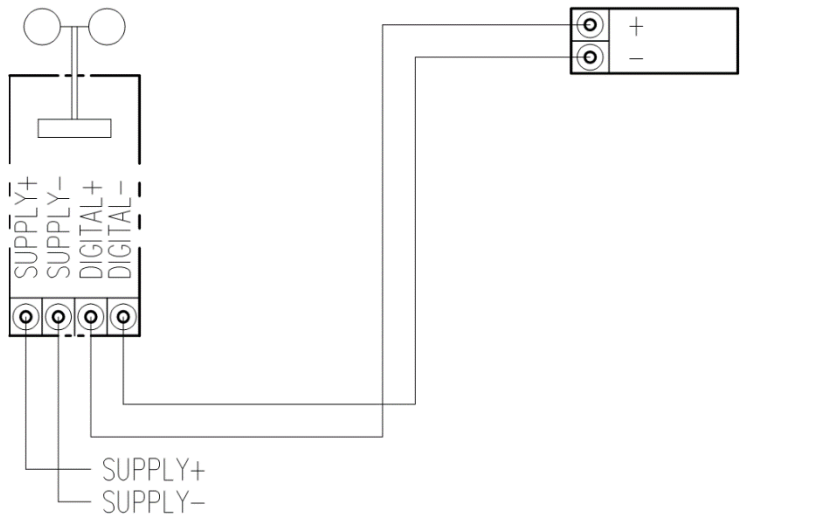

WIND SPEED MODBUS

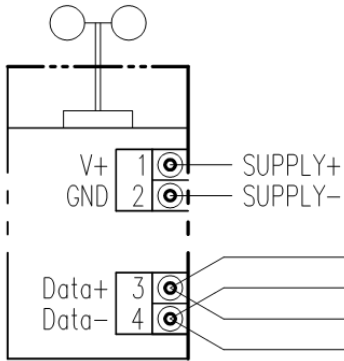

COM PORTS 2...5/6

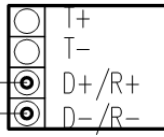

WIND DIRECTION MODBUS

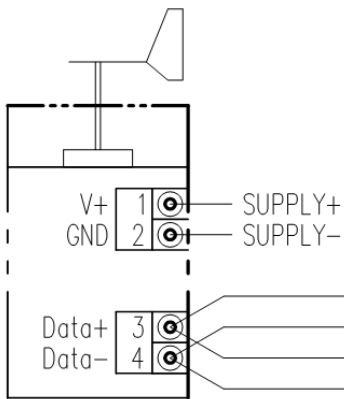

HUMIDITY-TEMPERATURE MODBUS

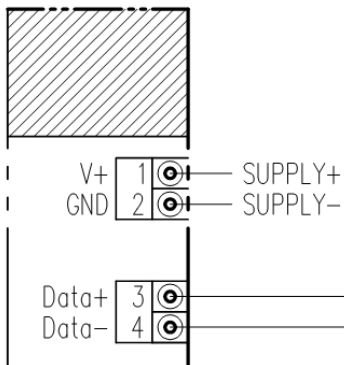

COM PORT 1

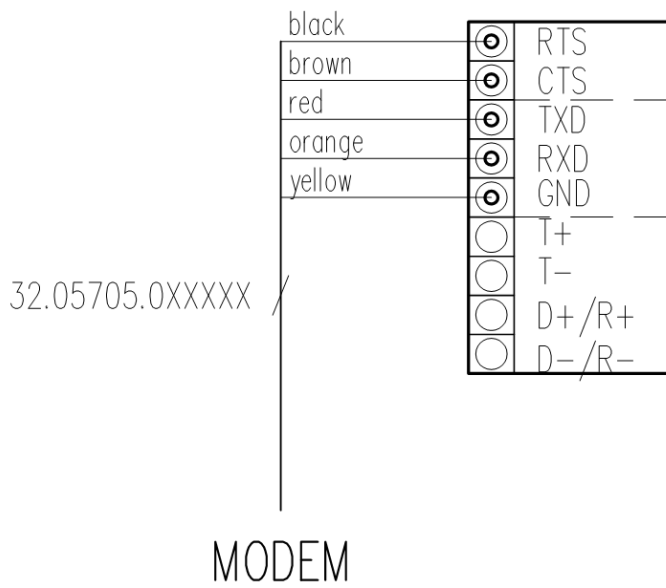

COM PORTS 2...5/6

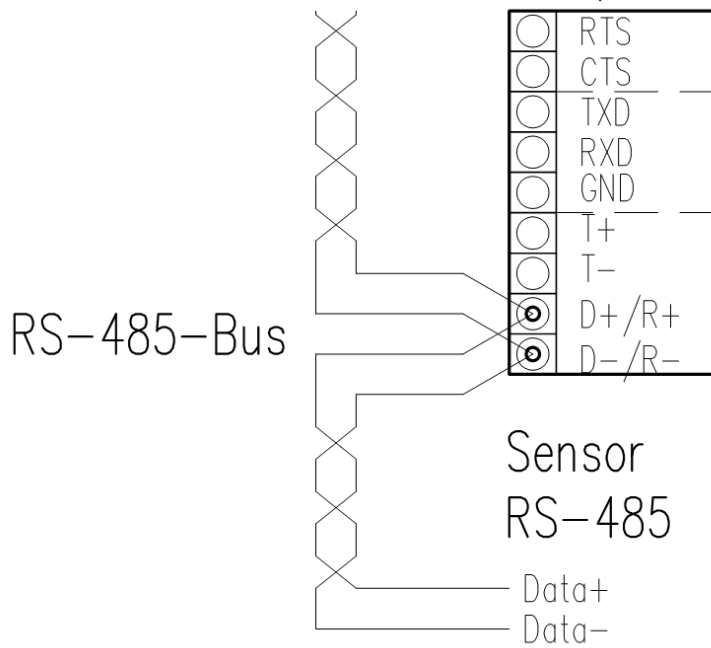

00.15184.000000

rain[e]

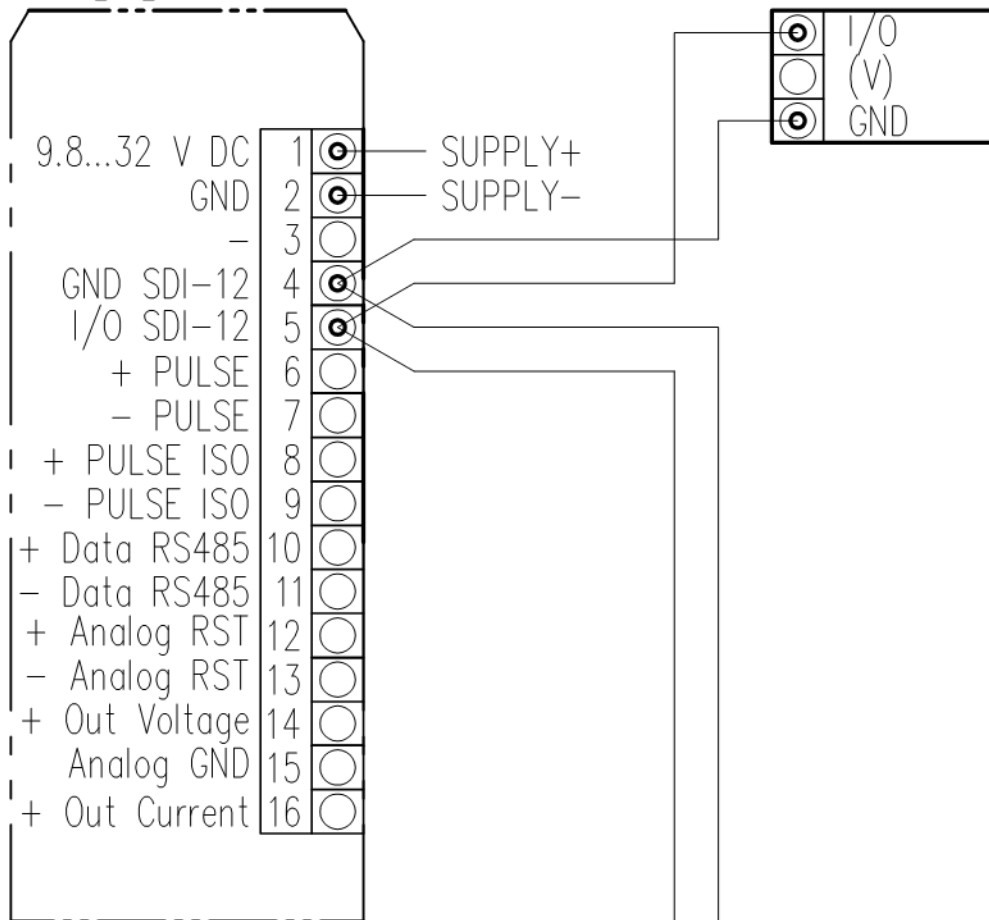

PRECIPITATION

SDI-12

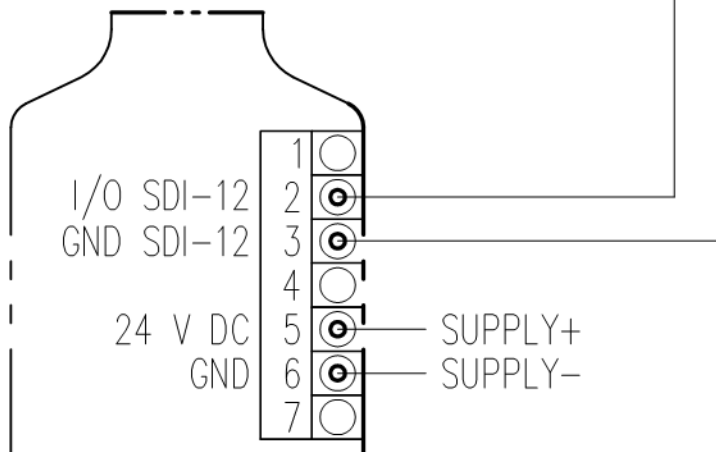

14 Supported serial protocols

The Ser[LOG] supports the following serial protocols:

Sensor Protocols

- NMEA
- RPT350
- PTB330
- LDWHM_12
- LD-40
- CL31 msg 2_base
- FS11
- rain[e] 'SDI-12 on RS485'
- Pluvio 1 DWD
- Pluvio 2 'M' command
- X81
- VFP-730 'compressed format'
- 15189 'SDI-12 on RS485'
- LPM Distrometer 'Tel. 6'
- Modbus Sensor
- SDI-12 (only COM5)

Other protocols

- SNAP
- GPRS PPP
- Modbus Actuator / Actor
- Ser[LOG] – AnDiMod-Bus

14.1 NMEA

The Ser[LOG] can process a subset of the data sets according to the NMEA 0183 standard. The RS422 interface is recommended. However, the Ser[LOG] can also receive NMEA protocols via the RS485 interface, provided that they are transmitted in talker mode (sensor sends the data sets automatically every second).

14.2 RPT350

Proprietary protocol of the precision air pressure sensor 00.08126.475002. The sensor is no longer available.

14.3 PTB330

Proprietary protocol of the precision air pressure sensor 00.08127.080002.

14.4 LDWHM_12

Proprietary protocol of the cloud height measuring device LDW HM-12 from Impulsphysik. The sensor is no longer available.

14.5 LD-40

Proprietary protocol of Vaisala's LD-40 cloud height meter. The sensor is no longer available.

14.6 CL31 msg 2_base

Proprietary protocol of the CL31 cloud height measuring device from Vaisala.

14.7 FS11

Proprietary protocol of the Vaisala FS11 visual range finder.

14.8 rain[e] 'SDI-12 on RS485'

Pseudo-SDI-12 protocol on an RS485 interface. The exact timing of an SDI-12 bus cannot be kept! Only one rain[e] and no other sensor can be connected to the interface. The address of the rain[e] must be set to 0. The sensor is queried every 20 seconds. Both the standard and extended SDI protocols of rain[e] are supported. Pseudo-SDI-12 protocol on an RS485 interface. The exact timing of the SDI-12 bus cannot be adhered to! Only one rain[e] and no other sensor can be connected to the interface. The address of the rain[e] must be set to 0. The sensor is queried every 20 seconds. Both the standard and extended SDI of rain[e] is supported.

14.9 Pluvio 1 DWD

Proprietary Talker protocol in the DWD version of Ott's Pluvio 1 precipitation sensor. The device is no longer available

14.10 Pluvio 2 'M Command'

Proprietary protocol of the precipitation sensor Pluvio 2 from OTT. With the M command, measured values are queried via RS485.

14.11 X81

Proprietary Talker protocol of the air pressure sensor 8126 X81.

14.12 VFP-730 'compressed format'

Proprietary Talker protocol of the Biral VFP-730 Visual Range / Present Weather sensor.

14.13 15189 'SDI-12 on RS485'

Pseudo-SDI-12 protocol on an RS485 interface. The exact timing of the SDI-12 bus cannot be adhered to! Only one 15189 serial and no other sensor can be connected to the interface. The address of the 15189 serial must be set to 0. The sensor is queried every 20 seconds.

14.14 LPM Distrometer 'Tel. 6'

Proprietary Talker protocol of the Distrometer LPM by Thies Clima.

14.15 Modbus Sensor

The Ser[LOG] can call up measured values from sensors that support Modbus RTU via the RS485 interface. Sensors are already defined in the sensor library, with which data can be retrieved via Modbus RTU. Further Modbus sensors can be defined by the user.

14.16 SDI-12 (only COM5)

SDI-12 sensors are configured in the Ser[LOG]-Commander via the COM5 interface. The Ser[LOG] supports only a subset of the SDI-12 specification. Only measured values from sensors generated with the CC command can be recorded.

Predefined sensors in the sensor library are available for the LAMBRECHT rain[e].

14.17 SNAP

The SNAP protocol is used for communication between the PC and the Ser[LOG]. If data are to be retrieved via an interface or the Ser[LOG] is to be configured, the SNAP protocol must be selected.

14.18 GPRS PPP

The GPRS PPP (Point-to-Point-Protocol) is used if the Ser[LOG] is to transmit data via GPRS or another internet-based mobile phone data transmission to the GPRS server of the LAMBRECHT evaluation software MeteoWare CS-4. See the MeteoWare CS-4 manual for further details on configuration.

14.19 Modbus Actuator / Actor

As described, among other things, the Ser[LOG] can switch up to 8 external Modbus relays within the scope of a process or cycle control or error and alarm messages. If the Modbus actuators are connected via a serial interface, the protocol "Modbus Actuator" must be selected accordingly.

14.20 Ser[LOG] – AnDiMod-Bus (only COM6)

If the Ser[LOG] is extended by an AnDiMod module, the LAMBRECHT specific protocol "Ser[LOG] - AnDiMod-Bus" must be selected on the COM6 interface.

15 List of predefined sensors

Status 08 March 2018

15.1 Predefined status sensors

15.1.1 Standard status sensors

D_Standard_status_actice=high	Standard sensor for the recording of states in which applies: logic 1 (true) at high level, e. g. 5V or switch open logic 0 (wrong) at low level, e. g. 0V or switch closed Serves as a basis for the definition of your own sensors.
D_Standard_status_active=low	Standard sensor for the recording of states in which applies: logic 1 (true) at low level, e. g. 0V or switch closed logic 0 (wrong) at high level, e. g. 5V or switch open Serves as a basis for the definition of your own sensors.

15.1.2 LAMBRECHT status sensors

E_16203.XX0004_Sunshine_duration	Sunshine duration sensor (16203) with status output. 0 V = Sun does not shine and 1 V = Sun shines
Service	Status sensor that prevents the storage of all averages at values > 0. Is switched on for professional systems during maintenance work.
Status	Clone of E_Standard_State_active=low

15.2 Predefined digital sensors

15.2.1 Standard digital sensors

E_Standard_Frequence_10000Hz	Standard sensor for recording frequencies up to 10000 Hz. Usually serves as a basis for the definition of own sensors.
E_Standard_State__active=high	Standard sensor for the recording of states in which applies: logic 1 (true) at high level, e. g. 5 V or switch open logic 0 (wrong) at low level, e. g. 0 V or switch closed Serves as a basis for the definition of your own sensors.
E_Standard_State__active=low	Standard sensor for the recording of states in which applies: logic 1 (true) at low level, e. g. 0 V or switch closed logic 0 (wrong) at high level, e. g. 5 V or switch open Serves as a basis for the definition of your own sensors.

15.2.2 LAMBRECHT digital sensors

E_14512.X70030_WS_I_35m/s	Wind speed of the combined wind sensor 14512 with inductive frequency output.
E_14576.010000_WS_Met_I600_60m/s	Wind speed of the wind speed sensor 00.14576.010000 with inductive frequency output.
E_14576.250004_WS_Met_Freq_60m/s	Wind speed of the wind speed sensor 00.14576.250004 with TTL frequency output.
E_15183.002000_Rain_2ccm_10mm	Precipitation sensor 15183 with 0.1 mm/m ² precipitation per pulse. Precipitation correction in Ser[LOG].
E_15183.004000_Rain_4ccm_20mm	Precipitation sensor 15183 with 0.2 mm/m ² precipitation per pulse. Precipitation correction in Ser[LOG].
E_15184.x00000_rain[e] H Res	Pulse output of the high-end precipitation sensor rain[e] with 0.01 mm/m ² precipitation per pulse. No additional precipitation correction in the Ser[LOG].

E_15184.x00000_rain[e] Standard	Pulse output of the high-end precipitation sensor rain[e] with 0.1 mm/m ² precipitation per pulse. Precipitation correction in the sensor, no additional correction in Ser[LOG].
E_15188.X02000_Rain_2ccm_10mm	Precipitation sensor 15188 with 0.1 mm/m ² precipitation per pulse. Precipitation correction in sensor, none in Ser[LOG].
E_15188.X02050_Rain_2ccm_10mm ++	Precipitation sensor 15188 with 0.1 mm/m ² precipitation per pulse. Precipitation correction in sensor.
E_15188.X04000_Rain_4ccm_20mm	Precipitation sensor 15188 with 0.2 mm/m ² precipitation per pulse. Precipitation correction in Ser[LOG].
E_15189.002000_Rain_2ccm_8mm	Precipitation sensor 15189 with 0.1 mm/m ² precipitation per pulse. Precipitation correction in Ser[LOG].
E_15189.004000_Rain_4ccm_16mm	Precipitation sensor 15189 with 0.2 mm/m ² precipitation per pulse. Precipitation correction in Ser[LOG].

15.3 Predefined analog sensors

15.3.1 Standard analog sensors

E_Standard_PT100_-100 ...+200°C	Standard temperature sensor with Pt100 within the limits of -100 to +200 °C. Serves as a basis for the definition of own sensors.
E_Standard_Voltage_+/-50mV	Standard sensor for voltages in the measuring range -50 mV to +50 mV. Serves as a basis for the definition of own sensors.
E_Standard_Voltage_+/-5V	Standard sensor for voltages in the measuring range -5 V to +5 V. Serves as a basis for the definition of own sensors.
E_Standard_Current +/-20mA	Standard sensor for currents in the measuring range -20 mA to +20 mA. Serves as a basis for the definition of own sensors.
E_Standard_Current 4...20mA	Standard sensor for currents in the measuring range 4 mA to +20 mA. Serves as a basis for the definition of own sensors.
E_Standard_Resistor__5000Ohm	Standard sensor for resistance measurements in the measuring range up to 5000 Ω. Serves as a basis for the definition of own sensors.
E_Standard_Resistor__500Ohm	Standard sensor for resistance measurements in the measuring range up to 500 Ω. Serves as a basis for the definition of own sensors.

15.3.2 LAMBRECHT analog sensors

E_08091.000042_Humidity 4-20mA	Humidity of the combined TH sensor 00.08091.000042 with 0...100%rh = 4...20 mA signal output
E_08091.000042_T_4-20mA_-30-70°C	Temperature of the combined TH sensor 00.08091.000042 with -30...+70 °C = 4...20 mA signal output
E_08092.330402_Humidity_0-1V	Humidity of the combined TH sensor 00.08092.330402 with 0...100%rh = 0...1 V signal output
E_08092.330402_Temperature_PT100	Temperature of the combined TH sensor 00.08092.330402 with Pt100 in the measuring range -40...+85 °C
E_08093.100000_Humidity 0-1V	Humidity of the combined TH sensor 00.08093.100000 with 0...100%rh = 0...1 V signal output
E_08093.100000_Temperature PT100	Temperature of the combined TH sensor 00.08093.100000 with Pt100 in the measuring range -40...+80 °C
E_08096.X30402_Humidity 0-1V	Humidity of the combined TH sensor 00.08093.x32402 with 0...100%rh = 0...1 V signal output
E_08096.230402_Temperature_PT100	Temperature of the combined TH sensor 00.08093.x30402 with Pt100 in the measuring range -40...+70 °C
E_08121.100002_P_0-20mA_600-1100	Air pressure sensor 00.08121.100002 configured to 0...20 mA = 600...1100 hPa
E_08121.100002_P_0-20mA_800-1100	Air pressure sensor 00.08121.100002 configured to 0...20 mA = 800...1100 hPa
E_08121.100002_P_0-2V_600-1100	Air pressure sensor 00.08121.100002 configured to 0...2 V = 600...1100 hPa
E_08121.100002_P_0-2V_800-1100	Air pressure sensor 00.08121.100002 configured to 0...2 V = 800...1100 hPa

E_08121.100002_P_4-20mA_600-1100	Air pressure sensor 00.08121.100002 configured to 4...20 mA = 600...1100 hPa
E_08121.100002_P_4-20mA_800-1100	Air pressure sensor 00.08121.100002 configured to 4...20 mA = 800...1100 hPa
E_08128.XXXXXX_P_0-5V_600-1060	Air pressure sensor of the series 8128 with 0...5 V = 600...1060hPa
E_08128.XXXXXX_P_0-5V_800-1060	Air pressure sensor of the series 8128 with 0...5 V = 800...1060hPa
E_08128.XXXXXX_P_0-5V_600-1100	Air pressure sensor of the series 8128 with 0...5 V = 600...1100hPa
E_08128.XXXXXX_P_0-5V_800-1100	Air pressure sensor of the series 8128 with 0...5 V = 800...1100hPa
E_08241.000000_Temp_PT100_-30-70	Grade temperature sensor Pt100 in the measuring range -30...+70 °C
E_08280.008503_Temp_PT100_-40-70	Ground/ Water/ Temperature sensor Pt100 in the measuring range -30...+70 °C
E_08281.008005_Temp_PT100_-30-70	Air temperature sensor Pt100 in the measuring range -30...+70 °C
E_08411.000000_soil moisture0-1V	Soil moisture sensor 8411 (TRIME) with 0...1 V = 0...100 % water content
E_14512.XX0030_WD_F1000	Wind direction of the combined wind sensor 14512 with potentiometer (1000 Ω).
E_14521.100040_WD_Prof_4-20mA	Wind direction sensor of the PROFESSIONAL series with 4...20 mA = 0...360°
E_14522.100040_WS_Pro_4-20_75m/s	Wind speed sensor of the PROFESSIONAL series with 4...20 mA = 0...75 m/s
E_14523.130040_WD_PRO_WEA	Wind direction sensor of the PRO-WEA series with 4...20 mA = 0...360°
E_14523.230040_WD_PRO_WEA/RF	Wind direction sensor of the PRO-WEA series with RF wind vane and 4...20 mA = 0...360°
E_14524.100040_WS_PRO_WEA	Wind speed sensor of the PRO-WEA series with 4...20 mA = 0...60 m/s
D_14524.200040_WG_PRO_WEA/RF	Wind speed sensor of the PRO-WEA series RF cup rotor and 4...20 mA = 0...60 m/s
E_14565.200304_WD_ECO_4-20	Wind direction sensor of the ECONOMY series with 4...20 mA = 0...360°
E_14566.000030_WD_Met_F1000	Wind direction sensor of the METEOROLOGY series with potentiometer (1000 Ω).
E_14566.200304_WD_Met_0-20mA	Wind direction sensor of the METEOROLOGY series Output: 0...20 mA = 0...360°
E_14566.200304_WD_Met_4-20mA	Wind direction sensor of the METEOROLOGY series Output: 0...20 mA = 0...360°
E_14567.X00000_WD_Ind_0-20mA	Wind direction sensor of the INDUSTRY series with 0...20 mA = 0...360°
E_14567.X00040_WD_Ind_4-20mA	Wind direction sensor of the INDUSTRY series with 4...20 mA = 0...360°
E_14575.200004_WS_0-20_35m/s	Wind speed sensor of the ECONOMY series Output: 0...20 mA = 0...35 m/s
E_14575.200004_WS_ECO_4-20_35m	Wind speed sensor of the ECONOMY series Output: 4...20 mA = 0...35 m/s
E_14576.250004_WS_Met_0-20_50m/s	Wind speed sensor of the METEOROLOGY series Output: 0...20 mA = 0...50 m/s
E_14576.250004_WS_Met_4-20_50m/s	Wind speed sensor of the METEOROLOGY series Output: 4...20 mA = 0...50 m/s
E_14577.X00000_WS_Ind_0-20_50m/s	Wind speed sensor of the INDUSTRY series with 0...20 mA = 0...50 m/s
E_14577.X00040_WS_Ind_4-20_50m/s	Wind speed sensor of the INDUSTRY series with 4...20 mA = 0...50 m/s
E_15235.100000_Evapor._5V_200mm	Level sensor for evaporation measurement with 0...5 V = 0...200 mm
E_16103.000000_Radiation	Second Class – Global radiation sensor with mV output. (EMK [in $\mu\text{V}/(\text{W}/\text{m}^2)$] must be specified individually for each sensor.)
E_16110.X00000_RB	Radiation balance sensor with mV output at one input. Observe special connection circuitry!
E_16123.000000_RB	Net radiometer with mV output.
E_16130.X00000_Radiation	Second Class – Global radiation sensor with mV output. (EMK [in $\mu\text{V}/(\text{W}/\text{m}^2)$] must be specified individually for each sensor.)
E_16131.X00000_Radiation	First Class – Global radiation sensor with mV output. (EMK [in $\mu\text{V}/(\text{W}/\text{m}^2)$] must be specified individually for each sensor.)
D_16321.010342_Helligkeit_4-20mA	Brightness sensor with 4...20 mA = 0...100 kLux

D_16470.000000_u[sonic]_WG_4-20	Wind speed of the combined ultrasound wind sensor u[sonic] with 4...20 mA = 65 m/s
D_16470.000000_u[sonic]_WR_4-20	Wind direction of the combined ultrasound wind sensor u[sonic] with 4...20 mA = 0...360°

15.4 Available serial sensors

15.4.1 LAMBRECHT serial sensors

E_15184.xxxxxx RS485 heater	rain[e] -Talker protocol - Status of heating
E_15184.xxxxxx RS485 status	rain[e] -Talker protocol - System status
E_15184.xxxxxx RS485 Precipitation	rain[e] -Talker protocol - Precipitation amount
E_15184.xxxxxx RS485 Temperature	rain[e] -Talker protocol - Internal temperature
PTB330	High-precision air pressure sensor 00.08127.080002
Pressure (RPT350) upto 1150hpa	High-precision air pressure sensor 00.08126.475002
E_08126.481002 DPS8100	High-precision air pressure sensor 00.08126.481002

15.4.2 LAMBRECHT SDI-12 sensors

Rain[e]_total_amount	rain[e] - Total quantity since last hardware reset
Rain[e]_Intensity per call in mm per h	rain[e] - Average precipitation intensity since last call-off in mm/h
Rain[e]_Intensity mm per min	rain[e] - Precipitation intensity in mm/min.
Rain[e]_Intensity per call in mm per min	rain[e] - Average precipitation intensity since last call-in mm/min.
Rain[e]_Intensity mm per h	rain[e] - Precipitation intensity in mm/h
Rain[e]_Amount per call	rain[e] - Precipitation since last call
Rain[e]_Amount calc with total amount	rain[e] - Precipitation per storage interval, calculated from the total amount of precipitation

15.4.3 LAMBRECHT Modbus sensors

MB_Rain[e]_total_amount_x.x	rain[e] - Total quantity since last hardware reset in 0.1 mm
MB_Rain[e]_total_amount_x.xxx	rain[e] - Total quantity since last hardware reset in 0.001 mm
MB_Rain[e]_Amount_by_total_amount	rain[e] - Precipitation per storage interval, calculated from the total amount of precipitation
MB_Rain[e]_Amount_per_call	rain[e] - Precipitation since last call
MB_THP_Pressure	THP (8095) - Air pressure in hPa
MB_THP_Humidity	THP (8095) - Relative humidity in % rh
MB_THP_Dewpoint	THP (8095) - Dew point in °C
MB_THP_Temp	THP (8095) - Air temperature in °C

15.4.4 NMEA sensors

NMEA Baro	Air pressure from protocol \$WIMMB delivered in hPa
NMEA Baro Inch Hg	Air pressure from protocol \$WIMMB delivered in InchHg
NMEA WR M MWV	Wind direction protocol from \$WIMWD M = magnetic direction
NMEA WR R MWV	Wind direction protocol from \$WIMWV R = relative direction
NMEA WR T MWV	Wind direction protocol from \$WIMWD T = true direction
NMEA WR T MWV	Wind direction protocol from \$WIMWV T = true direction
NMEA Abs. Hum.	Absolute humidity from \$WIMHU
NMEA Rel. Hum.	Relative humidity from \$WIMHU
NMEA TA	Air temperature from \$WIMTA in °C
NMEA TP	Dew point from \$WIMHU in °C
NMEA TS	Ground temperature from \$WIMTS (LAMBRECHT specific) in °C
NMEA TW	Water temperature from \$WIMTW °C in °C
NMEA WG m/s MWV	Wind speed from \$WIMWV in m/s (Ser[LOG] converts, if delivered in "kt")

NMEA WG MWD kt	Wind speed from \$WIMWD to kt (kn) (Ser[LOG] converts if delivered in "m/s")
NMEA WG MWD m/s	Wind speed from \$WIMWD to m/s (Ser[LOG] converts if delivered in "kt")
NMEA WG kt MWV	Wind speed from \$WIMWV to kt (kn) (Ser[LOG] converts if delivered in "m/s")

15.4.5 Additional serial sensors (proprietary)

CL31 Cloud Base 1 ft	Proprietary protocol of the CL31 cloud height measuring device from Vaisala. For detailed information on the parameters, please refer to the instructions of the respective sensors.
CL31 Cloud Base 1 m	
CL31 Cloud Base 2 m	
CL31 Cloud Base 2 ft	
CL31 Cloud Base 3 ft	
CL31 Cloud Base 3 m	
CL31 Cloud Detection Status	
CL31 Highest Signal Detected ft	
CL31 Highest Signal Detected m	
CL31 Vertical Visibility ft	
CL31 Vertical Visibility m	
FS11 Backgr. Luminance 10_min	Proprietary protocol of the Vaisala FS11 visual range finder. For detailed information on the parameters, please refer to the instructions of the respective sensors.
FS11 Backgr. Luminance 1_min	
FS11 FSM102 Window Corr. Factor	
FS11 LM21 Window Corr. Factor	
FS11 MOR_10_min	
FS11 MOR_1_min	
FS11 Status_BAL	
FS11 Status_IAL	
FS11 Status_VAL	
LD12 Cloud Base 1 ft	Proprietary protocol of the cloud height measuring device LDW HM-12 from Impulsphysik. The sensor is no longer available. For detailed information on the parameters, please refer to the specifications of the respective sensors.
LD12 Cloud Base 1 m	
LD12 Cloud Base 2 ft	
LD12 Cloud Base 2 m	
LD12 MROD ft	
LD12 MROD m	
LD12 Vertical Visibility ft	
LD12 Vertical Visibility m	
LD40 Cloud Base 1 ft	Proprietary protocol of Vaisala's LD-40 cloud height meter. For detailed information on the parameters, please refer to the instructions of the respective sensors.
LD40 Cloud Base 1 m	
LD40 Cloud Base 2 ft	
LD40 Cloud Base 2 m	
LD40 Cloud Base 3 ft	
LD40 Cloud Base 3 m	
LD40 MROD ft	
LD40 MROD m	
LD40 Vertical Visibility ft	
LD40 Vertical Visibility m	
P2_Container_EZ	Pluvio 2 precipitation sensor in SDI-12 mode. For detailed information on the parameters, please refer to the instructions of the respective sensors.
P2_Container_NEZ	
P2_Int_EZ	
P2_Amount_by_total_NEZ	
P2_Amount_EZ-NEZ	
P2_Amount_NEZ	
P2_Total_amount_NEZ	

P2_Status	Pluvio 2 precipitation sensor in SDI-12 mode. For detailed information on the parameters, please refer to the instructions of the respective sensors.
P2_Status_heater	
P2_Temperature_load_cell	
PLS_Level	PLS level sensor in SDI-12 mode. For detailed information on the parameters, please refer to the instructions of the respective sensors.
PLS_Temperature	
PLS_Temperature I	
WS501_Global_radiation	WS501 multiparameter (weather) sensor in SDI-12 mode. For detailed information on the parameters, please refer to the instructions of the respective sensors.
WS501_Global_radiation_AVR	
WS501_Air_pressure	
WS501_Air_temperature	
WS501_Relative_humidity	
WS501_Wind_speed	
WS501_Wind_speed_AVR	
WS501_Wind_direction	
WS501_Wind_direction_AVR	

15.4.6 Virtual sensors

E_Horizontal_visual_range	Virtual sensor only works in conjunction with the FS11 vision measuring device.
E_Meteorological_visual_range_MOR	Virtual sensor only works in conjunction with the FS11 vision measuring device.
E_Runway_visual_range_RVR	Virtual sensor only works in conjunction with the FS11 vision measuring device.
E_Standard_deviation_wind_speed	Vectorial calculation of the standard deviation of the wind speed. Requires a vectorially linked pair of sensors, consisting of a wind speed and a wind direction sensor.
E_Standard_deviation_wind_direction	Vectorial calculation of the standard deviation of the wind direction. Requires a vectorially linked pair of sensors, consisting of a wind speed and a wind direction sensor.
E_Variance_wind_speed	Vectorial calculation of the wind speed variance. Requires a vectorially linked pair of sensors, consisting of a wind speed and a wind direction sensor.
E_Variance_wind_direction	Vectorial calculation of the wind direction variance. Requires a vectorially linked pair of sensors, consisting of a wind speed and a wind direction sensor.
Humidity (psychrometer)	Calculation of relative humidity from dry temperature (sensor 1) and wet bulb temperature (sensor 2).
QFE	Conversion of the air pressure to a different height than the height of the air pressure sensor. Positive and negative height differences are allowed.
QFF	Reduction of air pressure to normal zero, taking into account the current values for air pressure, dew point and temperature.
QNH	Reduction of air pressure to Normal Zero, assuming a standard atmosphere.
STDEV	Calculation of the standard deviation of a selected parameter.
Dewpoint (T/H)	Calculation of the dew point temperature from air temperature and humidity.

15.4.7 Virtual Sensors - Special Function Redundancy

redundant absolute humidity	Two sensors are assigned to the virtual sensor. The first is the primary sensor and the second is the secondary sensor. As long as the primary sensor functions and supplies valid values, the value of the primary sensor is processed further. If the primary sensor does not work or returns invalid values, the secondary sensor value is processed further. If both sensors do not work, an error is displayed.
redundant relative humidity	
redundant temperature	
redundant air pressure	
redundant dew point	

16 Jumper field terminating resistor and interface driver RS485 / RS422

The Ser[LOG] has 6 serial interfaces, some of which can be operated as RS232, RS422 or RS485. Modbus and a SDI-12 interface are also available.

	RS232 hand- shake	RS232	RS422	RS485	Modbus	SDI-12	AnDiMod
COM1	X	X	X				
COM2		X	X	X	X		
COM3		X	X	X	X		
COM4		X	X	X	X		
COM5			X	X	X	X*	
COM6			(X)	(X)	(X)		X*

* separate Klemme • separate terminal

(X) nicht bei Ser[LOG]Plus • not at Ser[LOG]Plus

An RS232 interface with handshake line is only available on COM1.

If SDI-12 sensors are used, they are connected via the separate SDI-12 terminal on the Ser[LOG]. The COM5 interface is occupied by SDI-12 and the COM5 connection is deactivated.

If the Ser[LOG] is extended with one or more AnDiMod modules, the connection is made via the separate 4-pin terminal on the bottom of the housing. The AnDiMod modules occupy the COM6 interface and the COM6 connection is deactivated.

Since the Ser[LOG]Plus already has an integrated AnDiMod module, COM6 is not available from the outset.

COM2 to COM6 can be switched from RS485 (factory setting) to RS422 via jumper.

Please note that the configuration of the used interfaces must also be done on the software side with the Ser[LOG] Commander!

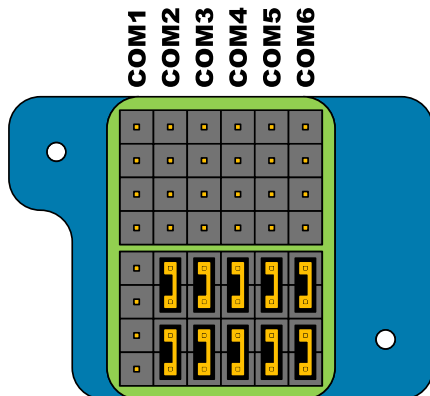

Factory setting:

COM1: RS232 or RS422*; no terminating resistors

COM2: RS232 or RS485*; no terminating resistors

COM3: RS232 or RS485*; no terminating resistors

COM4: RS232 or RS485*; no terminating resistors

COM5: RS485*; no terminating resistors

COM6: RS485*; no terminating resistors

*configurable via software

16.1 Switching the COM2 to COM6 from RS485 to RS422

The RS485 hardware drivers are activated at the COM2 to COM6 of the Ser[LOG] (factory-set).

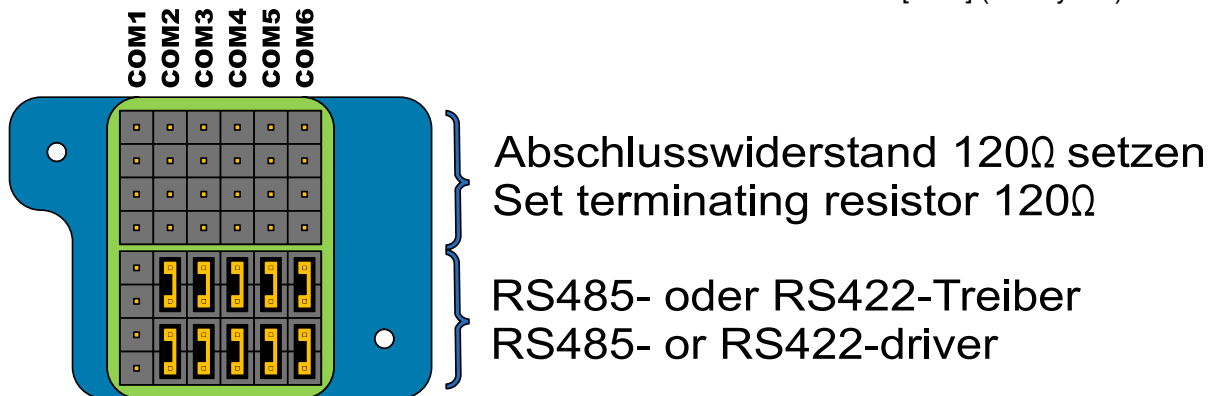

By loosening the two Torx screws (size Tx6) the small cover on the right above the COM ports can be removed and the jumper fields underneath can be reached.

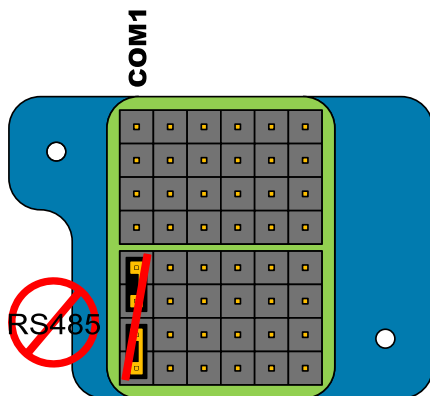

The hardware drivers of the COM interfaces COM2-COM6 can be switched from RS485 to RS422 via the lower jumper field.

COM 1 can only be operated as RS232 or RS422.
Switching to RS485 is not possible!

The functions of the COM interfaces that can be set are arranged in columns, with each column representing a COM interface, from left to right starting with COM1.

The COM interfaces COM2-COM6 can be operated as RS485 if the two lower jumpers are inserted in the column of the respective COM interface. If the two lower jumpers are not plugged in, the interface can be operated as RS422.

16.2 Adding terminating resistors for RS485 or RS422

As per factory-set, there are no terminating resistors connected to the COM1 to COM6 of the Ser[LOG]. If required, e. g. for long cable lengths, these can be added.

Note: Please note that switching on the 120 Ω terminating resistors increases the current consumption of the system. If the cable ends (e. g. at the sensor) are additionally terminated with terminating resistors, the current consumption increases additionally. The actual power consumption depends on the configuration and the overall system and must be determined separately if required.

By loosening the two Torx screws (size Tx6) the small cover on the right above the COM ports can be removed and the jumper fields underneath can be reached.

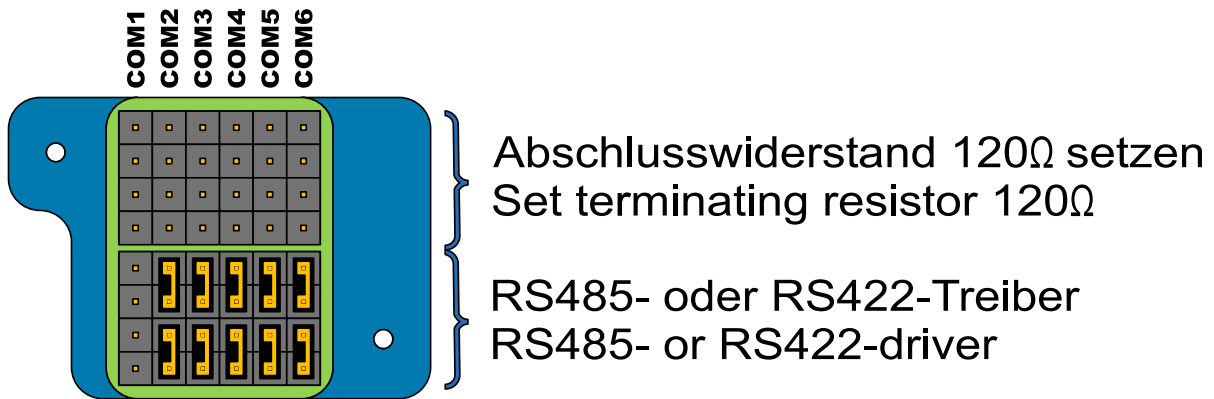

The 120 Ω terminating resistors can be added via the upper jumper field.

The functions of the COM interfaces that can be set are arranged in columns, with each column representing a COM interface, from left to right starting with COM1.

The terminating resistors are added when the two upper jumpers are inserted in the column of the respective COM interface.

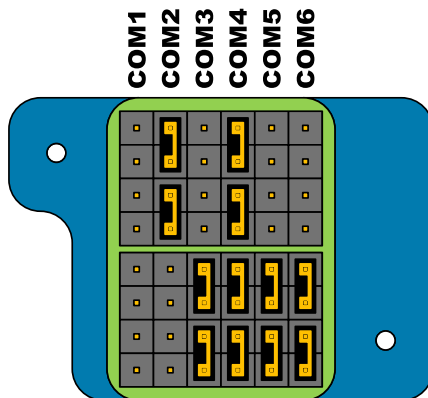

Example:

COM1: RS232 or RS422*; no terminating resistors

COM2: RS232 or RS422*; 120Ω terminating resistors

COM3: RS232 or RS485*; no terminating resistors

COM4: RS232 or RS485*; 120Ω terminating resistors

COM5: RS485*; no terminating resistors

COM6: RS485*; no terminating resistors

*configurable via software

17 Warranty

Please note the loss that unauthorized manipulation of the system shall result in the loss of warranty and non-liability. Changes to system components require express written permission from LAMBRECHT meteo GmbH. These activities must be performed by a qualified technician.

The warranty does not cover:

1. Mechanical damage caused by external impacts (e. g. icefall, rockfall, vandalism).
2. Impacts or damage caused by over-voltage or electromagnetic fields which are beyond the standards and specifications of the device.
3. Damage caused by improper handling, e. g. by using the wrong tools, incorrect installation, incorrect electrical installation (incorrect polarity) etc.
4. Damage caused by using the device outside the specified operation conditions.

18 Change history

28.08.2018 M. Müller	Chapter 2.2.5 Connection – Sensors with SDI-12-Interface - page 19 pasted.
28.08.2018 B. Schulz	Edits according to Dr. Henn

19 Ser[LOG] sensor assignment

Serial interfaces

Interface		Description	Lambrecht Id No.	Interface parameters Data bits / Stop bits / Parity / Handshake	Standard		Protocol
<input type="checkbox"/>	COM1				<input type="checkbox"/> RS 232	<input type="checkbox"/> RS 422	
<input type="checkbox"/>	COM2				<input type="checkbox"/> RS 232 <input type="checkbox"/> RS 422	<input type="checkbox"/> RS 485 <input type="checkbox"/>	
<input type="checkbox"/>	COM3				<input type="checkbox"/> RS 232 <input type="checkbox"/> RS 422	<input type="checkbox"/> RS 485 <input type="checkbox"/>	
<input type="checkbox"/>	COM4				<input type="checkbox"/> RS 232 <input type="checkbox"/> RS 422	<input type="checkbox"/> RS 485 <input type="checkbox"/>	
<input type="checkbox"/>	COM5				<input type="checkbox"/> RS 485 <input type="checkbox"/> SDI-12	<input type="checkbox"/> RS 422	
<input type="checkbox"/>	SDI-12				Note: SDI-12 occupies COM5		
<input type="checkbox"/>	COM6				<input type="checkbox"/> RS 422 <input type="checkbox"/> AnDiMod to Ser[LOG] bus	<input type="checkbox"/> RS 485	

Note: With Ser[LOG]Plus the COM6 is already occupied by an AnDiMod module!

Digital sensors

Interface		Description	Lambrecht Id No.	Measurement range		
<input type="checkbox"/>	DA			<input type="checkbox"/> Status high-active / low-active		
<input type="checkbox"/>	DB			<input type="checkbox"/> Status high-active / low-active		

19.1 Sensor assignment - AnDiMod or Ser[LOG]Plus analog section

AnDiMod Address 1 AnDiMod Address 2 AnDiMod Address 3 Ser[LOG]Plus (analog)

Analog sensors

Interface	Description	Lambrecht Id No.	Measurement range	Scaling		Unit
				Min	Max	
<input type="checkbox"/>	1			Signal: Value:	Signal: Value:	
<input type="checkbox"/>	2			Signal: Value:	Signal: Value:	
<input type="checkbox"/>	3			Signal: Value:	Signal: Value:	
<input type="checkbox"/>	4			Signal: Value:	Signal: Value:	
<input type="checkbox"/>	5			Signal: Value:	Signal: Value:	
<input type="checkbox"/>	6			Signal: Value:	Signal: Value:	
<input type="checkbox"/>	7			Signal: Value:	Signal: Value:	
<input type="checkbox"/>	8			Signal: Value:	Signal: Value:	
<input type="checkbox"/>	9			Signal: Value:	Signal: Value:	
<input type="checkbox"/>	10			Signal: Value:	Signal: Value:	
<input type="checkbox"/>	11			Signal: Value:	Signal: Value:	
<input type="checkbox"/>	12			Signal: Value:	Signal: Value:	

Digital sensors

Interface	Description	Lambrecht Id No.	Measurement range			Unit
<input type="checkbox"/>	D1		<input type="checkbox"/> Status high-active / low-active	<input type="checkbox"/> Pulse (e.g. precipitation)	<input type="checkbox"/> Frequency	
<input type="checkbox"/>	D2		<input type="checkbox"/> Status high-active / low-active	<input type="checkbox"/> Pulse (e.g. precipitation)	<input type="checkbox"/> Frequency	

<input type="checkbox"/>	D2			<input type="checkbox"/> Status high-active / low-active	<input type="checkbox"/> Pulse (e.g. precipitation)	<input type="checkbox"/> Frequency	
--------------------------	----	--	--	--	---	------------------------------------	--

19.2 Sensor assignment - AnDiMod or Ser[LOG]Plus analog section

AnDiMod Address 1 AnDiMod Address 2 AnDiMod Address 3 Ser[LOG]Plus (analog)

Analog sensors

Interface	Description	Lambrecht Id No.	Measurement range	Scaling		Unit
				Min	Max	
<input type="checkbox"/>	1			Signal: Value:	Signal: Value:	
<input type="checkbox"/>	2			Signal: Value:	Signal: Value:	
<input type="checkbox"/>	3			Signal: Value:	Signal: Value:	
<input type="checkbox"/>	4			Signal: Value:	Signal: Value:	
<input type="checkbox"/>	5			Signal: Value:	Signal: Value:	
<input type="checkbox"/>	6			Signal: Value:	Signal: Value:	
<input type="checkbox"/>	7			Signal: Value:	Signal: Value:	
<input type="checkbox"/>	8			Signal: Value:	Signal: Value:	
<input type="checkbox"/>	9			Signal: Value:	Signal: Value:	
<input type="checkbox"/>	10			Signal: Value:	Signal: Value:	
<input type="checkbox"/>	11			Signal: Value:	Signal: Value:	
<input type="checkbox"/>	12			Signal: Value:	Signal: Value:	

Digital sensors

Interface		Description	Lambrecht Id No.	Measurement range			Unit
<input type="checkbox"/>	D1			<input type="checkbox"/> Status high-active / low-active	<input type="checkbox"/> Pulse (e.g. precipitation)	<input type="checkbox"/> Frequency	
<input type="checkbox"/>	D2			<input type="checkbox"/> Status high-active / low-active	<input type="checkbox"/> Pulse (e.g. precipitation)	<input type="checkbox"/> Frequency	
<input type="checkbox"/>	D2			<input type="checkbox"/> Status high-active / low-active	<input type="checkbox"/> Pulse (e.g. precipitation)	<input type="checkbox"/> Frequency	

19.3 Sensor assignment - AnDiMod or Ser[LOG]Plus analog section

AnDiMod Address 1 AnDiMod Address 2 AnDiMod Address 3 Ser[LOG]Plus (analog)

Analog sensors

Interface		Description	Lambrecht Id No.	Measurement range	Scaling		Unit
					Min	Max	
<input type="checkbox"/>	1				Signal: Value:	Signal: Value:	
<input type="checkbox"/>	2				Signal: Value:	Signal: Value:	
<input type="checkbox"/>	3				Signal: Value:	Signal: Value:	
<input type="checkbox"/>	4				Signal: Value:	Signal: Value:	
<input type="checkbox"/>	5				Signal: Value:	Signal: Value:	
<input type="checkbox"/>	6				Signal: Value:	Signal: Value:	
<input type="checkbox"/>	7				Signal: Value:	Signal: Value:	
<input type="checkbox"/>	8				Signal: Value:	Signal: Value:	
<input type="checkbox"/>	9				Signal: Value:	Signal: Value:	
<input type="checkbox"/>	10				Signal: Value:	Signal: Value:	
<input type="checkbox"/>	11				Signal: Value:	Signal: Value:	
<input type="checkbox"/>	12				Signal: Value:	Signal: Value:	

Digital sensors

Interface		Description	Lambrecht Id No.	Measurement range			Unit
<input type="checkbox"/>	D1			<input type="checkbox"/> Status high-active / low-active	<input type="checkbox"/> Pulse (e.g. precipitation)	<input type="checkbox"/> Frequency	
<input type="checkbox"/>	D2			<input type="checkbox"/> Status high-active / low-active	<input type="checkbox"/> Pulse (e.g. precipitation)	<input type="checkbox"/> Frequency	
<input type="checkbox"/>	D2			<input type="checkbox"/> Status high-aktiv / low-aktiv	<input type="checkbox"/> Pulse (e.g. precipitation)	<input type="checkbox"/> Frequency	

20 ASCII character table

<i>Hexadecimal</i>	<i>Decimal</i>	<i>ASCII character</i>	<i>Hexadecimal</i>	<i>Decimal</i>	<i>ASCII character</i>
20,	32,	" "	50,	80,	"P"
21,	33,	"!"	51,	81,	"Q"
22,	34,	""	52,	82,	"R"
23,	35,	"#"	53,	83,	"S"
24,	36,	"\$"	54,	84,	"T"
25,	37,	"%"	55,	85,	"U"
26,	38,	"&"	56,	86,	"V"
27,	39,	""	57,	87,	"W"
28,	40,	"("	58,	88,	"X"
29,	41,	")"	59,	89,	"Y"
2A,	42,	"*"	5A,	90,	"Z"
2B,	43,	"+"	5B,	91,	"["
2C,	44,	","	5C,	92,	"\"
2D,	45,	"_"	5D,	93,	"]"
2E,	46,	"."	5E,	94,	"^"
2F,	47,	"/"	5F,	95,	" "
30,	48,	"0"	60,	96,	""
31,	49,	"1"	61,	97,	"a"
32,	50,	"2"	62,	98,	"b"
33,	51,	"3"	63,	99,	"c"
34,	52,	"4"	64,	100,	,"d"
35,	53,	"5"	65,	101,	,"e"
36,	54,	"6"	66,	102,	,"f"
37,	55,	"7"	67,	103,	,"g"
38,	56,	"8"	68,	104,	,"h"
39,	57,	"9"	69,	105,	,"i"
3A,	58,	":"	6A,	106,	,"j"
3B,	59,	","	6B,	107,	,"k"
3C,	60,	"<"	6C,	108,	,"l"
3D,	61,	"="	6D,	109,	,"m"
3E,	62,	">"	6E,	110,	,"n"
3F,	63,	"?"	6F,	111,	,"o"
40,	64,	"@"	70,	112,	,"p"
41,	65,	"A"	71,	113,	,"q"
42,	66,	"B"	72,	114,	,"r"
43,	67,	"C"	73,	115,	,"s"
44,	68,	"D"	74,	116,	,"t"
45,	69,	"E"	75,	117,	,"u"
46,	70,	"F"	76,	118,	,"v"
47,	71,	"G"	77,	119,	,"w"
48,	72,	"H"	78,	120,	,"x"
49,	73,	"I"	79,	121,	,"y"
4A,	74,	"J"	7A,	122,	,"z"
4B,	75,	"K"	7B,	123,	,"{"
4C,	76,	"L"	7C,	124,	," "
4D,	77,	"M"	7D,	125,	,"}"
4E,	78,	"N"	7E,	126,	,"~"
4F,	79,	"O"			

21 Technical data

Ser[LOG]

Id-No. 00.95770.000000

Category:	Professional Line Data Logger Multiprocessor system with 32 bit embedded realtime Linux core
Display:	LCD 2 lines of 16 characters each
Control element:	Rotary pushbutton
Communication interfaces:	5 x RS 485 · 6 x RS 422 · 4 x RS 232 · USB device · USB host · Ethernet
Signal inputs:	COM5 also available as SDI12 · 2 status inputs
Outputs:	2 potential-free, configurable relays · with max. 8 Modbus relays expandable to 10 relays
Ethernet:	100 MBit · Connector RJ45
Ext. power supply (V0):	10...30 VDC
Current consumption:	from 34 mA (12 V) up to 240 mA (12 V) depending on configuration
Ambient conditions:	-30 to +70 °C · 5 to 95 % r. h. (non-condensing)
EMC:	IEC 60945 - RS422 and RS485 up to 2.5 kV isolated · all interfaces with 15 kV ESD protection
Mounting bracket:	for 35 mm DIN rail
Dimensions/ Weight:	135 x 135 x 72 mm · approx. 0.9 kg
Housing:	aluminium milled, anodized and laser marked

Communication channels

Ser[LOG] - User:

optionally via USB storage medium, cable, network, Bluetooth, or mobile communication (GPRS, EDGE, UMTS, HDSP, LTE) · Support of dialogs (SNAP), FTP, email, SMS

Ser[LOG] - Sensors:

optional NMEA, Modbus-RTU, Modbus-TCP, SDI12 and numerous proprietary protocols (other protocols available on request)

Memory:	1 year in ring memory (8-byte IEEE real format) · independent of configuration
Scope of delivery:	USB cable · Configuration software Ser[LOG] Commander

Ser[LOG]Plus

Id-No. 00.95770.100000 – Alstom-Id-No. DTR0000532873

Technical like Ser[LOG]. Differences:

Communication interfaces: 4 x RS 485 · 5 x RS 422 · 4 x RS 232 · USB device · USB host · Ethernet
Analog/Digital inputs: 2 analog / 5 digital inputs
Resolution: 16-bit ADC (SAR) with up to 1024x oversampling
Measurement data processing: 8-byte IEEE real format
Outputs Sensor supply: 6x V0 (10... 30 VDC) · max. current output via all: 500mA
Dimensions/ Weight: 135 x 238 x 72 mm · approx. 1.3 kg

AnDiMod - expansion module analog/digital inputs

AnDiMod - Address 1 Article No. 00.95770.200000

AnDiMod - Address 2 Article No. 00.95770.200001

AnDiMod - Address 3 Article-No. 00.95770.200002

Extends the analog and digital inputs of Ser[LOG] and Ser[LOG]Plus (observe order!).

Communication interfaces: Ser[LOG]-Bus (RS485)
Analog/Digital inputs: 12 analog / 3 digital inputs
Ser[LOG] extension: up to 3 AnDiMod
Ser[LOG]Plus extension: up to 2 AnDiMod

Ser[LOG] and Ser[LOG]Plus are max. expandable to: 36 analog / 11 digital inputs

Resolution: 16-bit ADC (SAR) with up to 1024x oversampling
Measurement data processing: 8-byte IEEE real format
Power supply: via Ser[LOG] or Ser[LOG]Plus 10...30 VDC
Outputs sensor supply: 6x V0 (10...30 VDC) · max. current output via all: 500 mA
EMV: IEC 60945
Mounting bracket: for 35 mm DIN rail
Dimensions/ Weight: 135 x 114 x 72 mm · approx. 0.6 kg
Housing: aluminium milled, anodized and laser marked.

22 Disposal

LAMBRECHT meteo GmbH is registered at the Foundation Elektro-Altgeräte Register **ear** under:
WEEE-Reg.-No. DE 45445814

In the category “Monitoring and control instruments”, device type: “Industrial monitoring and control instruments”.



Disposal within the EU

The device must be disposed of acc. to the European regulations 2002/96/EG and 2003/108/EG (electronics and electronic waste). It is forbidden to throw electronic waste in the domestic waste! For environmentally friendly recycling and disposal of your electronic waste please consider a certified disposal business for electronic waste.

Disposal outside the EU

Please note the regulations for correct disposal of electronic waste in your country.

Subject to technical modifications.

SerLOG_Manual (17.21)

LAMBRECHT meteo GmbH
Friedlaender Weg 65-67
37085 Goettingen
Germany

Tel +49 551 4958 0
Fax +49 551 4958 312
E-Mail info@lambrecht.net
Internet www.lambrecht.net