

The Perfect Weather Sensor

- For industrial use as well as under extreme environmental conditions
- **5+1 Parameters in one** and at the same time
 - ▷ Wind direction
 - ▷ Wind speed
 - ▷ Air temperature
 - ▷ Air humidity
 - ▷ Barometric pressure
 - ▷ Dew point temperature (calculated value)
- With independent, integrated sensors for high accuracies of each individual parameter
- Without movable measuring elements, i. e. no abrasion, low maintenance and very easy to service

Applications

- Land applications under any conditions
- Wind turbines
- Railway line monitoring
- Traffic meteorology
- Weather services and Offices for the Environment
- Chemical and industrial facilities
- Power plants, sewage plants and landfills

Advantages at a Glance

- Extremely robust, compact weather sensor with high-quality, pollutant-resistant housing made of anodized aluminium
- Ideal for use in extreme environmental conditions, e.g. deserts, tropics, high mountains
- Version with integrated heating system for year-round icing-free operation
- Lamella shelter for accurate measurements of the temperature-humidity sensors
- ASCII data protocol according to NMEA 0183
- Power supply 6...60 VDC with integrated overvoltage protection
- Simple visualization of the measured values via Meteo-LCD indicators
- Storage, evaluation and display of the measured values using the "MeteoWare CS" evaluation software
- Easy, space-saving mounting on 50 mm standard pipe

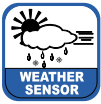

Contents

1	Introduction	3
1.1	Warranty	3
2	Setting to work	3
2.1	Installation conditions	3
2.1.1	Generally	3
2.2	Tools and installation aids	4
2.3	Unpacking the sensor	4
2.4	Goods inspection	4
2.5	Power supply	4
2.7	Mounting	4
2.7.1	North alignment of wind sensor	4
2.7.2	Power and signal connection	5
2.7.3	Safety regulations	5
3	Maintenance	5
3.1	Regular maintenance and calibration	5
3.2	Visual check and cleaning	5
4	Transports	5
5	Dimensional drawings and electrical connections	6
6	Data protocols u[sonic]WS6	7
7	Modbus data protocols u[sonic]	8
7.1	General	8
7.2	Data encoding	8
7.3	Standard configuration - Default	8
7.4	Available Modbus commands	9
7.5	Instantaneous values / realtime values (Input Register)	9
7.6	Period data - Average, maximum and minimum (Input Register)	9
7.7	Descriptive sensor parameter registers (Holding Register)	10
7.8	Configuration registers (Holding Register)	11
7.9	Autoconfiguration	11
8	SDI-12 Interface	12
9	Technical data	17
10	Disposal	17



1 Introduction

The sensors of the u[sonic] family are very robust, compact and extremely reliable.

The sensors embody the experience of more than 150 years of development and production of LAMBRECHT wind sensors.

The system acquires the horizontal air flow and processes the measuring data to the meteorological parameters wind speed and wind direction. Furthermore the weather-module of the u[sonic]WS6 acquires the meteorological parameters air temperature, relative humidity and barometric pressure. Based on the measured data u[sonic]WS6 calculates the dew point temperature and provides for its serial output along with the measuring data.

The sensors and further system components are mounted in a splash water- and dust proof metal housing.

The measuring data are automatically transmitted via serial interface RS-485 in talker mode, when power supply is switched on.

Due to their shock- and vibration proof construction the sensor u[sonic]WS6 is particularly qualified for use under severe environmental conditions. The housing is made of anodized seawater resistant aluminium.

An electronically controlled heating device enables the sensor to operate in between the wide range of -40 up to 70 °C.

1.1 Warranty

Please note the loss of warranty and non-liability by unauthorized manipulation of the system. You need a written permission of the LAMBRECHT meteo GmbH for changes of system components. These activities must be operated by a qualified technician.

The warranty does not cover:

1. Mechanical damages caused by external impacts (e. g. icefall, rockfall, vandalism).
2. Impacts or damages caused by over-voltages or electromagnetic fields which are beyond the standards and specifications in the technical data.
3. Damages caused by improper handling, e. g. by wrong tools, incorrect installation, incorrect electrical installation (false polarity) etc.
4. Damages which are caused by using the device beyond the specified operation conditions.

Static measuring principle for wind measurements means:

- Determination of data works without moving measuring elements, i.e. none abrasion, least maintenance and none recalibration because of this method.
- The wind parameter can be measured also in winter time accurate and precise, because of the electronic controlled heating for the immovable measuring elements. This heating is particularly effective against ice and snow in all climatic zones.
- The measuring principle allows very low starting values and high repeat accuracy.
- The sensor rapidly can be installed. Due to the special measuring principle minor changes from the angle of pitch can be disregarded.

Advantages of the sensor:

- Apart from the sensors for wind speed and direction the compact housing also contains built-in sensors for air temperature, relative humidity and barometric pressure.
- The built-in test function of the station, enabled by the tight integration of the meteorological sensors into the enclosure, can perform cyclic self-testing and notify the user of erroneous data or failure.
- The compact design of this sensor with 5 meteorological parameters is eliminating the traditional cabling and installation work significantly. Distribution boxes, power supply units and other accessories can be reduced to a minimum expense.

2 Setting to work

Wind can be represented by a vector quantity. For a complete description of the wind it is necessary to specify its speed and direction. The two components are subject to spatial and temporal variations; thus, strictly speaking, they are valid only for the site where the measuring instrument is installed. We therefore recommend selecting the place of installation very carefully.

2.1 Installation conditions

2.1.1 Generally

For professional wind measurements according to meteorological standards (e. g. VDI 3786, Part 2) location and height of the wind sensor are important for representative and accurate results. Generally, wind measuring instruments should not measure the specific wind conditions of a limited area, but indicate the typical wind conditions of a wider area. To obtain results which are representative for a wider area and comparable to values measured at different places, the sensor must not be mounted under the lee of higher obstacles. The distance to any obstacle should be at least 10 times the obstacle's height (corresponding to the definition of an undisturbed area). In general a measuring height of 10 m above ground is regarded ideal.

If an undisturbed terrain of this kind does not exist the sensor have to be put up at an height of at least 6 m above the obstacle height.

If the above mentioned requirements are not feasible e. g. on mobile measurements at vehicles or at measuring containers compromises have to be found and documented.

If the sensor must be installed on a roof top the place of installation must be in the middle of the roof to avoid predominant wind directions.

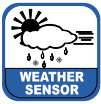

The place of installation should not be in the operation fields of radar devices (radar scanners or radar transmitters), generators or antennas. We recommend a minimum distance of 2 m to these installations. Furthermore a minimum distance of 5 m to MF-/ HF- and Satcom- (e. g. Inmarsat, VSat) antennas has to be kept. The maximum electric field intensity may not exceed 10 V/m (tested according to EMC standard). When indicated a greater distance should be kept.

To avoid possible measurement errors due to heat sources as hot or warm fumes, hot surfaces etc. next to the sensor, the mounting site should be chosen accordingly.

2.2 Tools and installation aids

There are no special tools or materials required for the installation works. All work can be carried out with commercially available tools such as screwdrivers and in-hex wrenches.

2.3 Unpacking the sensor

The sensor is packed in a separate box, carefully protected against mechanical influences during transport.

Please verify that the following parts and documents are enclosed:

- 1 sensor u[sonic]WS6
- 1 operating manual

Accessories: (depend on order size, in all cases separately packed)

Connecting cable with plug and core cable ends

2.4 Goods inspection

Please thoroughly check the delivery with regard to completeness and eventual transport damages. In case of eventual claims please contact us in writing immediately.

2.5 Power supply

The u[sonic]WS6 has a supply voltage range of 6...60 VDC. The sensor heater is supplied with 24 VDC and can be factory configured to 60 W, 120 W or 240 W. 240 W assuming the default setting.

2.6 Installation procedure (short instruction)

The installation of the sensor involves 3 steps:

- (1) Mounting the cable at the sensor and if necessary draw the cable through the mast.
- (2) Mounting the sensor at the mast, but before tightening the screws you must align the sensor to the north.
- (3) Attaching the cable to the power supply and the signal acquisition system.

2.7 Mounting

The sensor can be installed on a standard pipe with an outer diameter of 50 mm and an inner diameter of maximum 40 mm. Before tightening the two M8x12 grub screws and attaching the sensor you have to draw the cable through the pipe and align the sensor into driving direction.

For this purpose the housing is marked accordingly (see drawing). Before the screws of the sensor are tightened, the sensor is adjusted to north. Please pay attention to a firm mounting of the sensor at the mast!



Use only the supplied fixing screws and do not tighten the north screw tightly. Please pay attention to a firm mounting of the sensor at the mast!

2.7.1 North alignment of wind sensor

For wind direction measurements the north mark on the sensor must be aligned with the geographical north direction.

To adjust the wind sensor in a firm and correct manner into the north direction this item is equipped with an integrated mounting aid. Inside the inner bottom of the sensor a small bolt pointing to the north is integrated to be set into a corresponding slot of the mounting pipe (if available). Thus the sensor is safely attached. If needed you can turn in or unscrew the pin by means of in-hex wrench.

To set up the sensor's north orientation select a landmark which is as far as possible up north with regard to the final position of the wind direction sensor.

The reference point can be selected using a topographical map (1:25000). The exact position of the reference point is determined using an amplitude compass that can be adjusted horizontally on a stand.



Compass declination has to be considered!

To align the sensor ahead (on ships) locate a point outside the ship in the landscape which is located in the ship ahead direction respectively in the centre line or in case of the sensor is mounted far away from the middle line a line parallel to the centre line.

Once the sensor is adjusted, it can be fixed with the two grub screws. Finally the earth screw has to be connected to the ship's ground. Acid-free contact grease is recommended to protect contact surfaces against corrosion.



Note: Follow all safety instructions while setting up the sensor onto a mast.



2.7.2 Power and signal connection

The u[sonic]WS6 sensor requires a 8-pole M16 plug connector. The cable shield should be connected with both ends at the ground wire (PE).



To reduce the risk of inductive interference the sensor must be properly grounded (screening on both sides).

The external connection is via central connector which is located in housing base. For further details about electrical connection please see chapter „Connecting diagrams“.

If the sensor is mounted in correct manner and connected with the right cable (accessory), you can attach the wires to power supply and signal outputs to data acquisition equipment (computer).

The typical power supply requirements of the u[sonic]WS6 sensor are 24 Volts with a maximum current drain of 50 mA. The input range is max. 6... 60 VDC. The heating of the u[sonic]WS6 is supplied with 24 VDC. When the heating is activated, the current consumption increases to a maximum of 10 A.

The serial digital output of the sensor uses differential line drivers with high common mode noise rejection. The signal levels and timings conform to the requirements of EIA/RS-485 / Talker. The line drivers are capable of transmitting data over cable lengths up to 1,220 meters (4,000 feet). This maximum distance will vary depending upon the operational environment, the wire gauge used, and the baud- rate of the attached devices.

When the power supply of the sensor is switched on, after 5 seconds the sensor cyclically starts sending data protocols.

2.7.3 Safety regulations



Because the wind sensor often is mounted on exposed locations in dangerous heights the installation personnel has to pay attention to the relevant safety regulations for such works. During the electrical installation and termination works the external circuit-breaker must be switched off. - It is not permitted to open those housings by unauthorized persons!

3 Maintenance

3.1 Regular maintenance and calibration

The sensor u[sonic]WS6 is service reduced and designed for a very long lifetime. Recommended is a regular visual check regarding dirt of surface caused by the weather and if so, to clean up.



If reference measurements should be necessary stringently must be noted that a comparability of the measured values is given only if the measurements take place under same conditions. I.e. the reference equipment must be used very close to the sensor!

The sensor is a measuring instrument and thus apply user specific standards regarding period of recalibration.

Recommendation: 2 years.

We recommend to have the filter cap of the humidity-temperature sensor every two years exchanged in our plant. Depending on the application shorter maintenance cycles could be necessary.

3.2 Visual check and cleaning

The use of the sensor under the respective environmental conditions requires certain steps. It is thus recommendable to clean the outside of the housing and shelter within specific intervals. The intervals are dependant on the environmental conditions and the degree of soiling. We recommend a regular sight and functional check.

In case you should be faced with any specific problems please contact the LAMBRECHT meteo service under:

Tel.: +49-(0)551-4958-0

E-Mail: support@lambrecht.net

4 Transports

In case it is necessary to ship or to transport the sensor must be carefully packed to prevent damages during transport.

5 Dimensional drawings and electrical connections

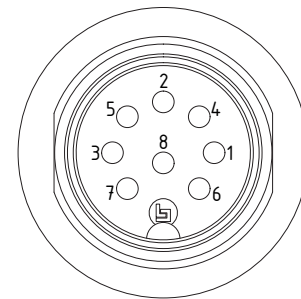
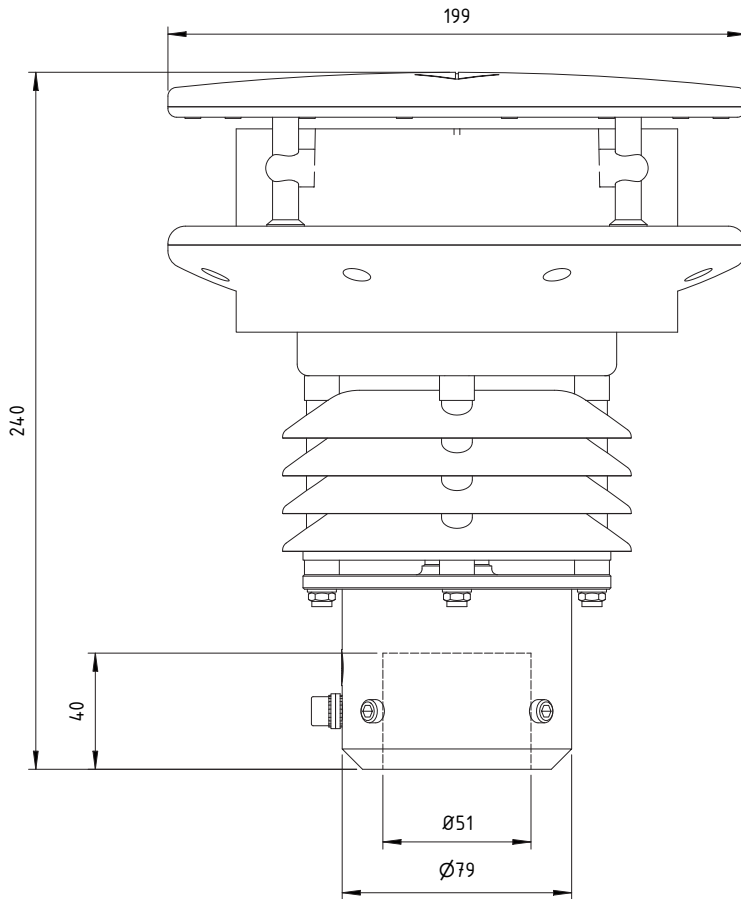

Ansicht Steckerseite
view male side

Stecker Pinbelegung			
Pin	Pinbelegung RS 485	Pinbelegung SDI-12	Kabelfarbe 32.164 70.060000
1	n.c.	n.c.	schwarz
2	Data -	SDI-12 Data	braun
3	Heizungs-Steuerung (konfigurierbar)	Heizungs-Steuerung (konfigurierbar)	rot
4	n.c.	n.c.	orange
5	Data +	SDI-12 GND	gelb
6	n.c.	n.c.	grün
7	+ 24V AC/DC nominal	+ 24V AC/DC nominal	blau
8	- 24V AC/DC nominal	- 24V AC/DC nominal	lila

Male side pin assignment			
Pin	Pin assignment RS 485	Pin assignment SDI-12	Cable color 32.164 70.060000
1	n.c.	n.c.	black
2	Data -	SDI-12 Data	brown
3	Heating Control (configurable)	Heating Control (configurable)	red
4	n.c.	n.c.	orange
5	Data +	SDI-12 GND	yellow
6	n.c.	n.c.	green
7	+ 24V AC/DC nominal	+ 24V AC/DC nominal	blue
8	- 24V AC/DC nominal	- 24V AC/DC nominal	violet



6 Data protocols u[sonic]WS6

NMEA Communication parameters

Baudrate: 4800 Baud
Data Bits: 8
Parity Bit: None (none)
Stop Bits: 1 (or more)
Handshake: without

Wind direction and wind speed

Example of data sequence with comma separated fields: \$WIMWV,357.0,R,5.2,M,A*CS<CR><LF>
field delimiter: , (comma)
header: \$WIMWV
wind direction: 0.0...360.0
R: relative wind direction
wind speed: 0.1...85.0
M metric units m/s
status A (valid) / V (not valid)
stop delimiters: <CR><LF>
error code: WD 999.9
error code: WS 999.9

Message string WIMTA air temperature

Example of data sequence with comma separated fields: \$WIMTA,-25.0,C*CS<CR><LF>
field delimiter: , (comma)
header: \$WIMTA
temperature: -40.0...+70.0
C: °C
stop limiters: <CR><LF>
error code: 999.9

Message string WIMHU relative humidity

Example of data sequence with comma separated fields: \$WIMHU,100.0,-40.0,C*CS<CR><LF>
field delimiter: , (comma)
header: \$WIMHU
rel. humidity: 000.0...100.0
dew point temp.: -40.0...+70.0
C: °C
stop limiters: <CR><LF>
error code: 999.9

Message string WIMMB barometric pressure

Example of data sequence with comma separated fields: \$WIMMB,,,1050.0,B*CS<CR><LF>
field delimiter: , (comma)
header: \$WIMMB
barometric pressure: 600.0...1100.0
B: air pressure in hPa
stop limiters: <CR><LF>
error code: 9999.9

Important! Please note:

Field length

The development of a NMEA decoder should not be proceeded from firm field lengths. The NMEA definition proceeds from a variable field length. The comma character (",") serves as field disconnecting switch. Numeric values in a field can be presented differently. In case a field is not sent, it has a length of 0 characters (,,) [comma-comma].

Check sum

The check sum "CS" is covered to two ASCII characters hexadecimal value. "CS" calculated by XOR operation of each character in the sentence between "\$" and "*", but excluding "\$" and "*".

Error code

In case, that the sensor cannot generate a measuring value because e.g. a sensor element is defect or implausible (raw) values are collected the sensor outputs in the corresponding data protocol the above mentioned error code (e.g. 999.9) and sets the status from "A" (valid) to "V" (not valid).

Example: \$WIMWV,999.9,R,999.9,M,V*37<CR><LF>

Particular characteristics wind direction value

Theoretically the value for the wind direction can take any value between 0.0° and 360.0°. It should be noted, that in a full circle the values "0.0" and "360.0" are describing the same direction. According to the international valid recommendations of the WMO (World Meteorological Organization) in the "Guide to Meteorological Instruments and Methods of Observation" (WMO-No.8) the wind direction value 0.0° just has to be output at calm. The u[sonic]WS6 follows the recommendation of the WMO and outputs at wind from the north the value "360.0" respectively "0.0" at calm (lull).

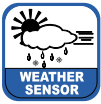

7 Modbus data protocols u[sonic]

Note: Modbus must be configured in default.

This manual covers the general Modbus specification common to all Modbus sensors from LAMBRECHT meteo. The manual allows easy operation of all LAMBRECHT meteo Modbus sensors. Some sensors of the Modbus family offer additional registers and functions, which are described in separate documents via the registers and functions described here. The registers and functions described in this manual are sufficient for general operation of Modbus sensors in a weather station or PLC.

7.1 General

The Lambrecht meteo Modbus sensors follow the specification of the Modbus organization: "MODBUS APPLICATION PROTOCOL SPECIFICATION V1.1b3". (See www.modbus.org).

7.2 Data encoding

MODBUS uses the "Big-Endian" format for addresses and data. This means that if a value is transmitted with a number format which is larger than a single byte, that the "most significant byte" is sent first.

Example Big-Endian:

Register size value 16 - bits

0x1234 is transmitted in the sequence: 0x12 0x34.

To obtain the real measuring value, divide the received register value by the divisor.

Values of -9999 indicate an internal sensor error.

7.3 Standard configuration - Default

Baud rate: 19200 Baud

Byte frame: 8E1 (1 start bit, 8 data bits, 1 parity bit (even parity), 1 stop bit)

RTU Sensor address: 5

Default addresses of the LAMBRECHT sensors:

Address	Sensor
1	Wind speed
2	Wind direction
3	Precipitation rain[e]
4	THP
5	EOLOS IND · u[sonic]WS6
6	com[b]
7	PREOS
8	ARCO
9	u[sonic]
10	Pyranometer 2nd Class
11	Secondary standard Pyranometer
12	PT100 to Modbus converter (temperature)
13	u[sonic]WS7

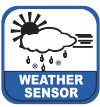

7.4 Available Modbus commands

The LAMBRECHT Modbus sensors support the following commands:

- “Read Holding Register” command: 0x03 (descriptive sensor data registers)
- “Read Input Register” command: 0x04 (measured values registers)
(every measured value is to be requested individually)
- “Write Multiple Register” command: 0x10 (Write to configuration registers)

7.5 Instantaneous values / realtime values (Input Register)

The following measured values are provided:

Register address	Parameter name	Unit	Divisor	Quantity of registers	Access type
30001	Wind speed	m/s	10	1	Read only
30201	Wind direction	°	10	1	Read only
30401	Air temperature	°C	10	1	Read only
30601	Relative humidity	% r. F.	10	1	Read only
30701	Dew point	°C	10	1	Read only
30801	Air pressure	hPa	10		Read only

Example: Retrieve wind speed

0D	04	75	31	00	01	7A	C5	0D	04	02	00	1F	E8	F9
----	----	----	----	----	----	----	----	----	----	----	----	----	----	----

LEN 6	Transmission Query =>	Source Master	Dest Slave 13	Function Read Input Register (4)	Func Desk Address=30001, Quantity of Register=1	Checksum OK:C57A
----------	--------------------------	------------------	------------------	-------------------------------------	----------------------------------------------------	---------------------

LEN 5	Transmission Response <=	Source Slave 13	Dest Master	Function Read Input Register (4)	Func Desk Byte count=2	Data 00 1F	Checksum OK:F9E8
----------	-----------------------------	--------------------	----------------	-------------------------------------	---------------------------	---------------	---------------------

7.6 Period data - Average, maximum and minimum (Input Register)

Register	Parameter name	Unit	Divisor	Quantity of registers	Access type
30002	Wind speed average	m/s	10	1	Read only
30003	Wind speed maximum	m/s	10	1	Read only
30004	Wind speed minimum	m/s	10	1	Read only
30202	Wind direction average	°	10	1	Read only
30203	Wind direction maximum	°	10	1	Read only
30204	Wind direction minimum	°	10	1	Read only
30402	Air temperature average	°C	10	1	Read only
30403	Air temperature maximum	°C	10	1	Read only
30404	Air temperature minimum	°C	10	1	Read only
30602	Relative humidity average	% r. F.	10	1	Read only
30603	Relative humidity maximum	% r. F.	10	1	Read only
30604	Relative humidity minimum	% r. F.	10	1	Read only
30702	Dew point average	°C	10	1	Read only
30703	Dew point maximum	°C	10	1	Read only
30704	Dew point minimum	°C	10	1	Read only
30802	Air pressure average	hPa	10	1	Read only
30803	Air pressure maximum	hPa	10	1	Read only
30804	Air pressure minimum	hPa	10	1	Read only

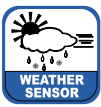

The data are valid for the period between the current request and the previous request. The maximum range of a period is 1 hour. Recalling the average value of a minimum, maximum and average group will erase the appropriate registers.

Retrieve the values of a group in the sequence minimum, maximum, average.

Use command: 0x03

Example: Retrieve wind speed (min. max. avr.) and erase the register content

01	04	75	34	00	01	6A	08	01	04	02	00	00	B9	30	01
04	75	33	00	01	DB	C9	01	04	02	00	D6	38	AE	01	04
75	32	00	01	8A	09	01	04	02	00	14	B9	3F			

LEN 6	Transmission Query =>	Source Master	Dest Slave 1	Function Read Input Register (4)	Func Desk Address=30004, Quantity of Register=1	Checksum OK:86A
LEN 5	Transmission Response <=	Source Slave 1	Dest Master	Function Read Input Register (4)	Func Desk Byte count=2	Data 00 00 Checksum OK:30B9
LEN 6	Transmission Query =>	Source Master	Dest Slave 1	Function Read Input Register (4)	Func Desk Address=30003, Quantity of Register=1	Checksum OK:C9DB
LEN 5	Transmission Response <=	Source Slave 1	Dest Master	Function Read Input Register (4)	Func Desk Byte count=2	Data 00 D6 Checksum OK:AE38
LEN 6	Transmission Query =>	Source Master	Dest Slave 1	Function Read Input Register (4)	Func Desk Address=30002, Quantity of Register=1	Checksum OK:98A
LEN 5	Transmission Response <=	Source Slave 1	Dest Master	Function Read Input Register (4)	Func Desk Byte count=2	Data 00 14 Checksum OK:3FB9

7.7 Descriptive sensor parameter registers (Holding Register)

Register	Parameter name	Quantity of registers	Remark	Access type
40050	Device identification number (15 characters)	8 (2 characters in each register)	The returned data are in form of a 16 byte null terminated string	Read only
40100	Serial number (11 characters)	6 (2 characters in each register)	The returned data are in form of a 12 byte null terminated string	Read only
40150	Firmware version (up to 25 characters)	13 (2 characters in each register)	The returned data are in form of a 26 byte null terminated string	Read only

Example: Retrieve the device identification number

(The identification number shown in the example is sensor-dependent. It is only used here for demonstration purposes).

0D	03	9C	72	00	08	CA	8B	0D	03	10	30	30	2E	31	36	□□□□□□□□□□□□□□
34	38	30	2E	30	30	31	31	33	30	00	E8	6B				00.16480.000130□□
LEN 6	Transmission Query =>	Source Master	Dest Slave 13	Function Read Holding Register (3)	Func Desk Address=40050, Quantity of Register=8	Checksum OK:8BCA										
LEN 19	Transmission Response <=	Source Slave 13	Dest Master	Function Read Holding Register (3)	Func Desk Byte count=16	Data 30 30 2E 31 36 34 38 30 2E 30 30 31 31 33 30 00 Checksum OK:6BE8										



7.8 Configuration registers (Holding Register)

Register	Parameter name	Allowed values	Quantity of registers	Access type
40001	Modbus device address		1	Write only
40200	Baud rate	96 = 9600 192 = 19200 384 = 38400	1	Write only
40201	Parity	1 = even 0 = none	1	Write only

The device must be restarted after each change of a setting!

Example: Change the RTU address from 4 to 1

05	10	9C	41	00	01	02	00	01	06	48	05	10	9C	41	00
01	7E	09													

LEN	Transmission	Source	Dest	Function	Func Desk	Byte count	Register values	Checksum
9	Query =>	Master	Slave 5	Write Multiple Register (16)	Address=40001, Quantity=1	2	00 01	OK:4806
LEN	Transmission	Source	Dest	Function	Func Desk	Checksum		
6	Response <=	Slave 5	Master	Write Multiple Register (16)	Address=40001, Quantity=1	OK:097E		

7.9 Autoconfiguration

All Lambrecht Modbus sensors offer the experienced user the possibility to implement an auto-configuration in his Modbus master based on additional information stored in the sensor.

The necessary information can be found in the document "Lambrecht_Modbus_Autoconfiguration".



8 SDI-12 Interface



SDI-12 has to be preconfigured ex works.

Please specify when ordering: Id-No. 97.16470.000002 Configuration SDI-12

The communication using SDI-12 protocol via SDI-12 interface is based on the 'SDI-12 A Serial-Digital Interface Standard for Microprocessor-Based Sensors, Version 1.4, 2017'. The u[sonic] can be used in bus mode parallel to other u[sonic].

The following subset of SDI-12 commands were implemented into the u[sonic].

For more information on the SDI-12 protocol, please refer to the standard documentation mentioned above or the website www.SDI-12.org.

Implemented SDI-12 commands:

Command	Function	Answer of the sensor
a!	Acknowledge Active	a<CR><LF>
al!	Send Identification	alccccccmmmmmmvvvxx...xx<CR><LF>
aAb!	Change Address	b<CR><LF>
aC!	Start Concurrent Measurement	atttn<CR><LF>
aCC!	Start Concurrent Measurement and Request CRC checksum	atttn<CR><LF>
aD0!	Send Data (Buffer 0)	a<data><CR><LF> a<data><CRC><CR><LF>
aV!	Start Verification	atttn<CR><LF>
aX!	Resetting the Addresses	a<CR><LF>

a = address of the respective sensor;

Standard sensor address = 0

SDI-12 commands always start with the address of the appropriate sensor. Therefore all other sensors on the same bus will ignore these commands. SDI-12 commands end with '!'. All answers from sensors start with its address, too, but end with the ASCII characters 'Carriage Return' <CR> and 'Line Feed' <LF>.

The SDI-12 protocol is based on the ASCII character set. The baud rate of the SDI-12 protocol is 1200 Bd and has the byte frame format:

- 1 start bit
- 7 data bits (least significant bit transmitted first)
- 1 parity bit (even parity)
- 1 stop bit

Acknowledge Active - a!

This command ensures that the sensor responds to requests. Basically it asks the sensor to confirm that it is connected to the bus.

The sensor returns its address and <CR><LF>.

Syntax

Command	Answer
a!	a<CR><LF>
a – Sensor address	a – Sensor address
! – End of command	<CR><LF> – End of answer

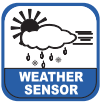

Example:

Command	Answer
0!	0<CR><LF>
1!	1<CR><LF>

Send Identification - a!

The command **a!** is used to ask the sensor for its model number and firmware version.

Syntax

Command	Answer
a! a – Sensor address ! – Command "Send Identification"	a14LMGmbH151647011.1<CR><LF> a – Sensor address a14LMGmbH151647011.1 14 – 2 characters SDI-12 version-No. 14 = version 1.4 LMGmbH15 – 8 characters manufacturer's (= Lambrecht meteo GmbH) 164701 – 6 characters sensor type 1.1 – Firmware version <CR><LF> – End of answer
! – End of command	

Example:

Command	Answer
0!!	014LMGmbH1514582S1.1<CR><LF>
1!!	114LMGmbH1514582D1.1<CR><LF>

Change address - aAb!

The factory setting for the address is "0".

If there are several sensors connected to one bus, the sensor address can be changed with the command **aAb!**.

The address is always a single ASCII character. Standard for addresses are the ASCII characters "0" to "9" (decimal 48 to 57). If there are more than 10 sensors connected to one bus, using the characters "A" to "Z" (decimal 65 to 90) and "a" to "z" (decimal 97 to 122) is allowed. The sensor answers with its new address and <CR><LF>.

After the address is changed, one should not send further commands to the sensor for a period of one second.

(See also "SDI-12 Standard, Version 1.4, 2017")

Syntax

Command	Answer
aAb! a – Old sensor address A – Command 'Change Address' b – New sensor address ! – End of command	b<CR><LF> b – New sensor address <CR><LF> – End of answer

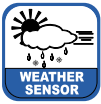

Example:

Command	Answer
0A1!	1<CR><LF>

Start Concurrent Measurement - aC!

The "Concurrent Measurement" enables the data logger to measure simultaneously with multiple sensors on the same bus. The "aC!" command requests the sensor to process the available measurement data and write them to an output string. Unlike the standard sensors described in the SDI-12 documentation, the u[sonic] measures continuously. This is why the u[sonic] always responds with "a000". The data is therefore immediately available. This is also the reason why the u[sonic] does not send a "service request" and ignores measurement interruption commands. The data can be retrieved with the command "aD0!" (see below under "Send data"). The data is not overwritten until the next "C" or "M" command and can be retrieved several times.

Syntax

Command	Answer
aC! a – Sensor address C – Command 'Start Concurrent Measurement' ! – End of command	a00004<CR><LF> a – Sensor address 000 – Seconds the sensor needs until the measured data can be returned (= 0 s – Data immediately available) 4 – Number of provided measured data <CR><LF> – end of answer

Example:

Command	Answer
1C!	100004<CR><LF>

The measured data can be requested with the command aD0! (see "Send Data").

Start Concurrent Measurement and Request - CRC aCC!

Same command as "aC!" but in addition to the generated data the sensor returns a 3-digit checksum. For information on how the CRC checksum gets generated, please consult 'SDI-12 Standard Version 1.4, 2017, chapter 4.4.12'.

Syntax

Command	Answer
aCC! a – Sensor address C – Command 'Start Concurrent Measurement' C – Request for transmission of the CRC checksum ! – End of command	a00004<CR><LF> a – Sensor address 000 – Seconds the sensor needs until the measured data can be returned with "CRC" (= 0 s – Data immediately available) 04 – Number of provided measured data <CR><LF> – End of answer

Example:

Command	Answer
1CC!	100004<CR><LF>



Send Data - aD0!

The data requested by the sensor with the commands "C" or "M" can be retrieved with the command "aD0!". The sensor uses the corresponding signs ("+" or "-") as field separators. If the data was requested with a "CC" or "MC" command, a CRC checksum is also returned. For more information on how to generate this CRC checksum, see "SDI-12 Standard, Version 1.4, 2017, chapter 4.4.12".

After the measurement, the data is stored in the buffer "D0" and retrieved with the command "aD0!".

Definition SDI-12 u[sonic]WS6

C! and CC!

	No.	Parameter	Description	Unit
D0!	1	wind speed	instantaneous value	m/s
	2	wind speed	minimum value	m/s
	3	wind speed	maximum value	m/s
	4	wind speed	average value	m/s
	5	wind direction	instantaneous value	deg
	6	wind direction	minimum value	deg
	7	wind direction	maximum value	deg
	8	wind direction	average value	deg
D1!	9	temperature	instantaneous value	°C
	10	temperature	minimum value	°C
	11	temperature	maximum value	°C
	12	temperature	average value	°C
	13	humidity	instantaneous value	%
	14	humidity	minimum value	%
	15	humidity	maximum value	%
	16	humidity	average value	%
D2!	17	dew point	instantaneous value	°C
	18	dew point	minimum value	°C
	19	dew point	maximum value	°C
	20	dew point	average value	°C
	21	air pressure	instantaneous value	mbar
	22	air pressure	minimum value	mbar
	23	air pressure	maximum value	mbar
	24	air pressure	average value	mbar
D3!	25	acoustic virtual temperature	instantaneous value	°C
	26	acoustic virtual temperature	minimum value	°C
	27	acoustic virtual temperature	maximum value	°C
	28	acoustic virtual temperature	average value	°C
D4!	29	status code	8 bit value	
	30	error code	8 bit value	

Minimal, maximum and average value refer to the time since last C! or CC! command.

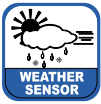

Syntax for measurements with command "aC!" or "aM!"

Command	Answer
aD0! a – Sensor address D – Command 'Send Data' 0 – Request for the data in buffer 0 or 1 = buffer 1 2 = buffer 2 ! – End of command	a<values><CR><LF> a – Sensor address <values> – Requested data separated by resp. sign ("+" or "-") <CR><LF> – End of answer

Example:

Command	Answer
0C!	000004<CR><LF>
0D0!	0+0.1+0.1+0.1+0.1<CR><LF>

Syntax for measurements with command "aCC!" or "aMC!"

Command	Answer
aD0! a – Sensor address D – Command 'Send Data' 0 – Request for the data in buffer 0 or 1 = buffer 1 ! – End of command	a<values><CRC><CR><LF> a – Sensor address <values> – Requested data separated by resp sign ("+" or "-") <CRC> – 3-digit CRC checksum <CR><LF> – End of answer



9 Technical data

(16480) Weather Sensor u[sonic]WS6

ID 00.16480.000000

Range of application: -40...+70 °C
-50...+70 °C heated
0...100 % r. h.

Parameters:

Wind direction

Measuring principle: ultrasonic
Measuring range: 0...359.9°
Accuracy: < 2° (>1 m/s) RMSE
Resolution: 0.1°

Wind speed

Measuring principle: ultrasonic
Measuring range: 0...65 m/s
Accuracy: 0.2 m/s RMSE(v < 10 m/s) •
2 % RMSE(10 m/s < v < 65 m/s)
Resolution: 0.1 m/s

Temperature

Measuring principle: digital temperature sensor
Measuring range: -40...+70 °C
Accuracy: 0.1 K (0...60 °C) ¹⁾ •
0.2 K (-40...0 °C) ¹⁾
Resolution: 0.1 °C

Relative humidity

Measuring principle: capacitive, digital
Measuring range: 0...100 % r. h.
Accuracy: 1.5 % (0...80 %) r. h. ²⁾³⁾
2 % (>80 %) r. h.
Resolution: 0.1 % r. h.

Barometric pressure

Measuring principle: piezoresistive
Measuring range: 300...1100 mbar
Accuracy: 0.5 mbar
Resolution: 0.1 mbar

Dew point temperature

Measuring principle: passive • calculated from air temperature and humidity
Measuring range: -40...+70 °C
Resolution: 0.1 °C

Trigger threshold: 0.1 m/s
Interface: RS 485 / 422 • SDI-12 (optional)
Protocols: NMEA 0183 (default) • Modbus and SDI-12 (optional)
Measuring rate: 0.1...10 Hz
Supply voltage: 6...60 VDC
heating: 24 VAC/DC ± 20 %
Current consumption: sensor: typically 50 mA at 24 VDC
heating: max. 10 A at 24 VAC/DC

Heating data: factory configurable:
60 W / 120 W / 240 W (standard)
Dimensions: H 238 mm; Ø 199 mm; mast adapter Ø 50 mm for mounting on standard pipe
Housing: seawater resistant aluminium
IP 66; IP 67
Weight: approx. 3.1 kg

Standards

- NMEA 0183
- Standard of construction: VDE 0100
- Low voltage guide line: 72/23 EWG
- EMC/EMI: DIN EN 60945 and DIN EN 61000-4-2, 3, 4, 6, 11
- Salt fog: EN 60945
- Protection class: DIN EN 60529

Accessories: (please order separately)

32.16420.066100 Sensor cable, 15 m, 8 pole M16 plug

Options: (please order separately)

36.09340.000000 Visualization and evaluation software MeteoWare-CS3
00.95800.010000 Data logger met[LOG]
00.14742.401002 Display unit METEO-LCD/IND

¹ Temperature influence of the shelter: accuracy +1.5 °C at v < 2 m/s and intensive solar radiation
² Temperature influence of the shelter: ± < 0.1 % r.h. at +10...+40 °C
³ Shelter inaccuracy: < 4 % r.h. dependant on v > 2 m/s and solar radiation

10 Disposal

LAMBRECHT meteo GmbH is listed and registered at the Stiftung Elektro-Altgeräte Register ear under:

WEEE-Reg.-No. DE 45445814

In the category of monitoring and control instruments, device type: "Monitoring and control instruments for exclusively commercial use".

Within the EU



The device has to be disposed according to the European Directives 2002/96/EC and 2003/108/EC (Waste Electrical and Electronic Equipment). Do not dispose the old device in the household waste! For an environmentally friendly recycling and disposal of your old device, contact a certified disposal company for electronic waste.

Outside the EU

Please follow the regulations in your country regarding the appropriate disposal of waste electronic equipment.



Quality System certified by DQS according to DIN EN ISO 9001:2015 Reg. No. 003748 QM15

Subject to change without notice.