



u[sonic] - Precision Meets Design

The ultrasonic wind sensor u[sonic] was specially designed for extreme environmental conditions. It comes without any moving measuring elements and is ideal for high wind speeds.

The extreme robust, compact sensor has a high-quality, pollutant-resistant housing made of hard anodized aluminium and stainless steel.

Applications

- ✓ Under icing conditions
- ✓ Onshore and offshore applications
- ✓ Wind turbines
- ✓ Railway line monitoring
- ✓ Traffic meteorology
- ✓ Chemical and industrial facilities
- ✓ Power plants, sewage plants and landfills

Advantages at a Glance

- Three parameters in one device:
 - ▶ Wind direction
 - ▶ Wind speed
 - ▶ Virtual temperature
- Without movable measuring elements
- No abrasion, low maintenance
- Standard RS 485 interface with ESD protection
- ASCII data protocol according to NMEA 0183
- Power supply (without heating) 6...60 VDC or 12...42 VAC
- Power supply (with heating) 24 V AC/DC $\pm 20\%$
- Simple, space-saving assembly on 50 mm standard pipe
- Analogue output 0...20 mA, 4...20 mA, 0...5 V or 0...10 V for wind speed and wind direction
- Heating power 60 W, 120 W, 240 W (standard)



Contents

1	Introduction	3
1.1	Warranty advices	3
1.2	Advantages of the static measuring principle	3
2	Setting to work	3
2.1	Installation conditions	3
2.1.1	Generally	3
2.2	Tools and installation aids	4
2.3	Unpacking the sensor	4
2.4	Goods inspection	4
2.5	Power supply	4
2.5.1	Power input	4
2.6	Installation procedure (short instruction)	4
2.7	Mounting	4
2.7.1	North alignment of wind sensor	4
2.7.2	Power and signal connection	5
2.7.3	Safety regulations	5
3	Maintenance	5
3.1	Regular maintenance and calibration	5
3.2	Visual check and cleaning	5
4	Transports	5
5	Plug connection u[sonic]	6
6	Dimensional drawing and electrical connection u[sonic]	7
7	NMEA data protocols u[sonic]	8
8	Modbus data protocols u[sonic]	9
8.1	General	9
8.2	Data encoding	9
8.3	Standard configuration - Default	9
8.4	Available Modbus commands	10
8.5	Instantaneous values / realtime values (Input Register)	10
8.6	Period data - Average, maximum and minimum (Input Register)	10
8.7	Descriptive sensor parameter registers (Holding Register)	11
8.8	Configuration registers (Holding Register)	12
8.9	Autoconfiguration	12
9	SDI-12 Interface	13
10	Technical Data	18



1 Introduction

The wind sensor u[sonic] is very robust, compact and extremely reliable. When developing this sensor particular consideration has been given to highest quality for fulfilment of meteorological requirements.

The system acquires the horizontal air flow and processes the measuring data to the meteorological parameters wind speed and wind direction.

The sensor is mounted in a splash water- and dust proof metal housing (IP66 and IP67) and can be immersed temporarily.

The measuring data are automatically transmitted via serial interface RS 485 in talker mode, when power supply is switched on.

Due to their shock- and vibration proof construction the sensor u[sonic] is particularly qualified for use under severe environmental conditions. The housing is made of anodised seawater resistant aluminium and stainless steel.

An electronically controlled heating device enables the sensor to operate in between the wide range of -40 up to 70 °C.

1.1 Warranty advices

Please note the loss of warranty and non-liability by unauthorised manipulation of the system. You need a written permission of the Lambrecht meteo GmbH for changes of system components. These activities must be operated by a qualified technician.

The warranty does not cover:

1. Mechanical damages caused by external impacts (e. g. icefall, rockfall, vandalism).
2. Impacts or damages caused by over-voltages or electromagnetic fields which are beyond the standards and specifications in the technical data.
3. Damages caused by improper handling, e. g. by wrong tools, incorrect installation, incorrect electrical installation (false polarity) etc.
4. Damages which are caused by using the device beyond the specified operation conditions.

1.2 Advantages of the static measuring principle

The sensor u[sonic] is a modern system to carry out precise and reliable measurements under hardest application and environmental conditions. The wind measurements take place according to the principle "ultrasonic run-time measurement", i. e. static, without moving parts.

Static measuring principle for wind measurements means:

- Determination of data works without moving measuring elements, i.e. none abrasion and least maintenance.
- The wind parameter can be measured also in winter time accurate and precise, because of the electronic controlled heating for the immovable measuring elements. This heating is particularly effective against ice and snow in all climatic zones.

- The measuring principle enables very low threshold values, distance- and attenuation constants as well as a very high repetition accuracy.

Advantages of the sensor:

- The built-in test function of the station, enabled by the tight integration of the meteorological sensors into the enclosure, can perform cyclic self-testing and notify the user of erroneous data or failure.
- The compact design of the sensor u[sonic] with 3 meteorological parameters is eliminating the installation work significantly.

2 Setting to work

Wind can be represented by a vector quantity. For a complete description of the wind it is necessary to specify its speed and direction. The two components are subject to spatial and temporal variations; thus, strictly speaking, they are valid only for the site where the measuring instrument is installed. We therefore recommend selecting the place of installation very carefully.

2.1 Installation conditions

2.1.1 Generally

For professional wind measurements location and height of the wind sensor are important for accurate, correct results and representative wind conditions. Ideally, the sensor should be installed in 10 m above the ground on a mast. This may be buildings, trees, tall towers, lifting cranes, moving vehicles, aircrafts, helicopters and other obstructions. In case of mobile measurements at vehicles often above mentioned conditions are not practicable. Then you have to find compromises.

Generally, wind measuring instruments should not measure the specific wind conditions of a limited area, but indicate the typical wind conditions of a wider area. The values measured at different places must be comparable. Thus, when installing the sensor you should make sure the place of installation is not under the lee of great obstacles. The distance between the obstacles and the sensor should be 10 times the height of the obstacles (this corresponds to the definition of an undisturbed terrain).

If an undisturbed terrain of this kind does not exist the sensor must be put up at a height of at least 6 m above the obstacle height.

If the sensor must be installed on a roof top the place of installation must be in the middle of the roof to avoid predominant wind directions. If you want to measure both wind direction and wind speed, the sensors should be avoided. The sensor u[sonic] easily meets this requirement.



The place of installation should not be in the operation fields of radar devices (radar scanners or radar transmitters), generators or antennas. We recommend a minimum distance of 2 m to these installations. Furthermore a minimum distance of 5 m to MF-/ HF- and Satcom- (e. g. Inmatsat, VSat) antennas has to be kept. The maximum electric field intensity may not exceed 10 V/m (tested according to EMC standard). When indicated a greater distance should be kept.

2.2 Tools and installation aids

There are no special tools or materials required for the installation works. All work can be carried out with standard tools, e.g. Allen key size 4.

2.3 Unpacking the sensor

The sensor is packed in a separate box, carefully protected against mechanical influences during transport.

Please verify that the following parts and documents are enclosed:

- 1 sensor u[sonic]
- 1 operating manual

Accessories: (depend on order size, separately packed)

Connecting cable with plug and core cable ends



2.4 Goods inspection

Please thoroughly check the delivery with regard to completeness and eventual transport damages. In case of eventual claims please contact us in writing immediately.

2.5 Power supply

The sensor requires at the input connector a 6..60 VDC or 12...42 VAC nominal power source for operation. For heating mode a 24 V AC/DC power supply is needed.

2.5.1 Power input

The power input of the u[sonic] is around approx. 25 mA at 24 VDC. The following table shows the maximum power input according to configured heating power.

Heating power	max. power input at 24 VDC
60 W	2.5 A
120 W	5 A
240 W (standard)	10 A

Heating power is configured to 240 W as a standard. Other values to be configured at works on request.

2.6 Installation procedure (short instruction)

The installation of the sensor involves 3 steps:

- (1) Mounting the cable at the sensor and if necessary draw the cable through the mast.
- (2) Mounting the sensor at the mast, but before tightening the screws you must align the sensor to the north.
- (3) Attaching the cable to the power supply and the signal acquisition system.

2.7 Mounting

The sensor can be installed on a standard pipe with an outer diameter of 50 mm and an inner diameter of maximum 40 mm. Before tightening the two 8 mm-socket screws and attaching the sensor you have to draw the cable through the pipe and align the sensor into driving direction.

For this purpose the housing is marked accordingly (see drawing). Before the screws of the sensor are tightened, the sensor is adjusted to north. Please pay attention to a firm mounting of the sensor at the mast!

In addition the sensor has a pin for the north direction. You can put this pin into the nick at the mast (if available). If needed you can turn in or unscrew the pin by means of allen key.

2.7.1 North alignment of wind sensor

For wind direction measurements the north mark on the sensor must be aligned with the geographical north direction.

To adjust the wind sensor in a firm and correct manner into the north direction this item is equipped with an integrated mounting aid. Inside the inner bottom of the sensor a small bolt pointing to the north is integrated to be set into a corresponding slot of the mounting pipe (if available). Thus the sensor is safely attached. If needed you can turn in or unscrew the pin by means of allen key.

To set up the sensor's north orientation select a landmark which is as far as possible up north with regard to the final position of the wind direction sensor.

The reference point can be selected using a topographical map (1:25000). The exact position of the reference point is determined using an amplitude compass that can be adjusted horizontally on a stand.



Compass declination has to be considered!



To align the sensor ahead (on ships) locate a point outside the ship in the landscape which is located in the ship ahead direction respectively in the centre line or in case of the sensor is mounted far away from the middle line a line parallel to the centre line.

Once the sensor is adjusted, it can be fixed with the two hexagon socket screws. Finally the earth screw has to be connected to the ship's ground. Acid-free contact grease is recommended to protect contact surfaces against corrosion.



Follow all safety instructions while setting up the sensor onto a mast.

2.7.2 Power and signal connection

The sensor u[sonic] requires a 8-pole plug connector. The cable shield should be connected with both ends at the ground wire (PE).



To reduce the risk of inductive interference a properly grounding of the sensor is recommended.

The external connection is via central connector which is located in housing base. For further details about electrical connection please see chapter „Connecting diagrams“.

If the sensor is mounted in correct manner and connected with the right cable (accessory), you can attach the wires to power supply and signal outputs to data acquisition equipment (computer).

The typical power supply requirements of the u[sonic] sensors are 24 VDC with a typical current drain of 35 mA. The input range is 6...60 VDC or 12...42 VAC. The heater of the u[sonic] has to be supplied with 24 V AC/DC. In standard configuration the heating power is 240 W with a current drain of 10 A at 24 VDC.

The signal output of the sensors is conform to the requirements of RS422 standard in talker mode. The line drivers are capable of transmitting data over cable lengths up to 1,220 meters (4,000 feet). This maximum distance will vary depending on the quality of the used cables.

When the power supply of the sensor is switched on, after 2 seconds the sensor cyclically starts sending data protocols.

2.7.3 Safety regulations



Because the wind sensor often is mounted on exposed locations in dangerous heights the installation personnel has to pay attention to the relevant safety regulations for such works. During the electrical installation and termination works the external circuit-breaker must be switched off.

It is not permitted to open those housings by unauthorized persons!

3 Maintenance

3.1 Regular maintenance and calibration

The sensor u[sonic] is service reduced and designed for a very long lifetime. Recommended is a regular visual check regarding dirt of surface caused by the weather and if so, to clean up.



If reference measurements should be necessary stringently must be noted that a comparability of the measured values is given only if the measurements take place under same conditions. I.e. the reference equipment must be used very close to the sensor!

The sensor is a measuring instrument and thus apply user specific standards regarding period of recalibration.

Recommendation: 2 years.

3.2 Visual check and cleaning

The use of the sensor under the respective environmental conditions requires certain steps. It is thus recommendable to clean the outside of the housing within specific intervals. The intervals are dependant on the environmental conditions and the degree of soiling. We recommend a regular sight check.

In case you should be faced with any specific problems please contact the Lambrecht service under:

Tel.: +49-(0)551-4958-0

E-Mail: support@lambrecht.net

4 Transports

In case it is necessary to ship or to transport the sensor must be carefully packed to prevent damages during transport.

5 Plug connection u[sonic]

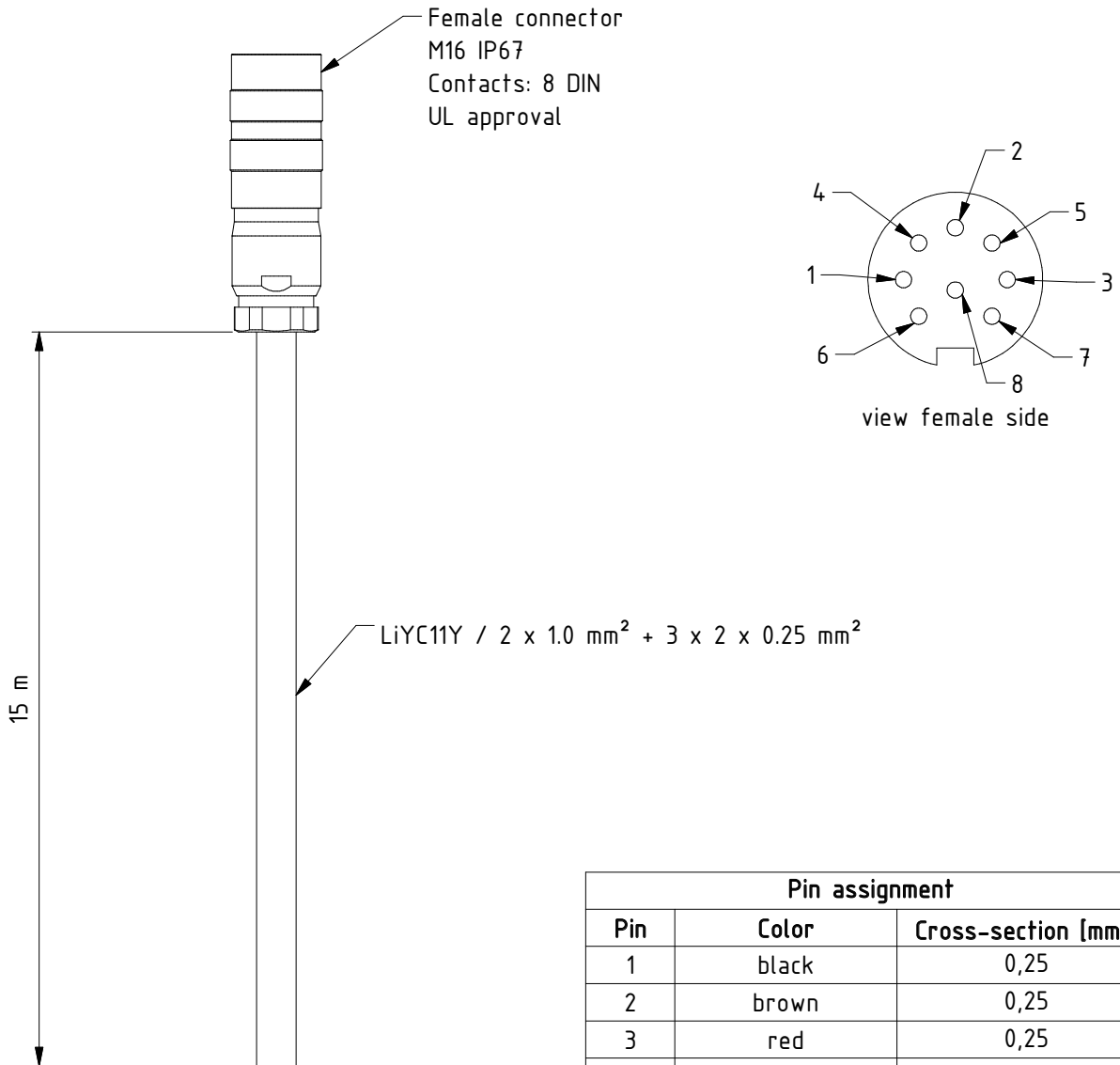

Pin assignment		
Pin	Color	Cross-section [mm ²]
1	black	0,25
2	brown	0,25
3	red	0,25
4	orange	0,25
5	yellow	0,25
6	green	0,25
7	blue	1
8	violet	1

6 Dimensional drawing and electrical connection u[sonic]

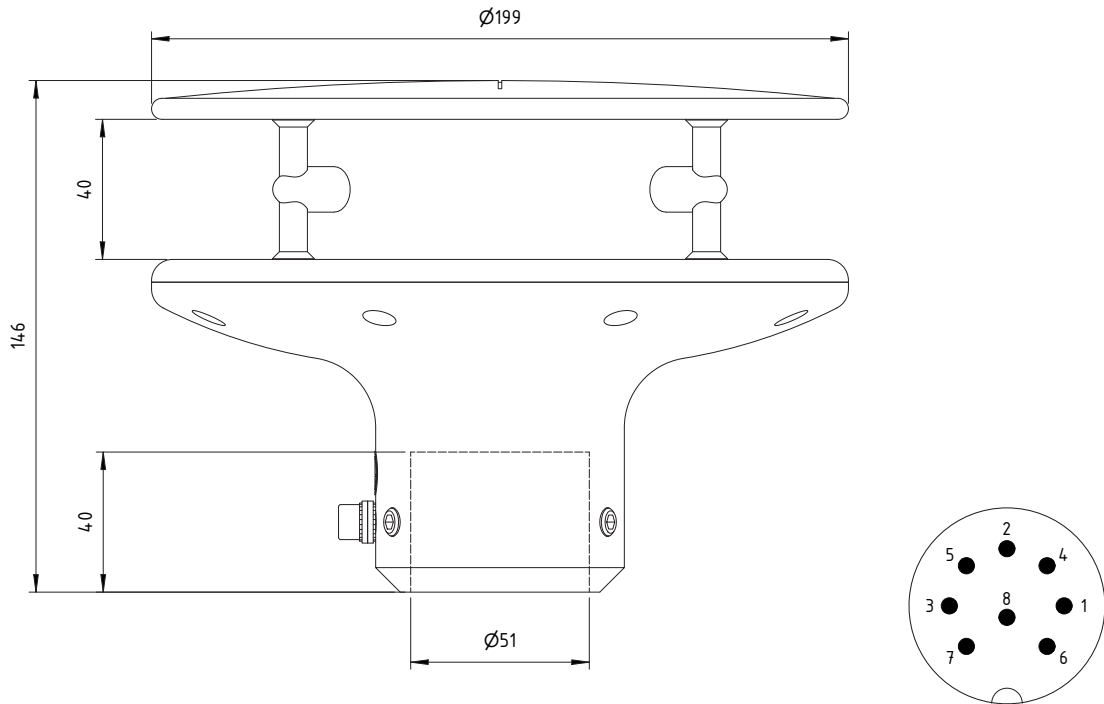

Ansicht Steckerseite
 view male side

00.16470.100000				
Pin	Pin assignment RS 485	Pin assignment RS 422	Pin assignment SDI-12	Cable color 32.16470.060000
1	Wind speed (analog)	Rx-	Wind speed (analog)	black
2	Data-	Tx-	+ Data I/O SDI-12	brown
3	Heating Control (configurable)	Heating Control (configurable)	Heating Control (configurable)	red
4	Wind direction (analog)	Rx+	Wind direction (analog)	orange
5	Data+	Tx+	- GND SDI-12	yellow
6	AGND	AGND	AGND	green
7	+ 24 V AC / DC nominal	+ 24 V AC / DC nominal	+ 24 V AC / DC nominal	blue
8	- 24 V AC / DC nominal	- 24 V AC / DC nominal	- 24 V AC / DC nominal	violet



7 NMEA data protocols u[sonic]

NMEA Communication parameters:

Baudrate: 4800 Baud
Data Bits: 8
Parity Bit: None (none)
Stop Bits: 1 (or more)
Handshake: without

Wind direction and wind speed

Example of data sequence with comma separated fields: \$WIMWV,357.0,R,5.2,M,A*CS<CR><LF>
field delimiter: , (comma)
header: \$WIMWV
wind direction: 0.0...360.0
R: relative wind direction
wind speed: 0.1...85.0
M metric units m/s
status A (valid) / V (not valid)
stop delimiters: <CR> <LF>
error code: WD 999.9
error code: WS 999.9

Message string WIMTA air temperature

Example of data sequence with comma separated fields: \$WIMTA,-25.0,C*CS<CR><LF>
field delimiter: , (comma)
header: \$WIMTA
temperature: -40.0...+70.0
C: °C
stop limiters: <CR> <LF>
error code: 999.9

Remark

The development of a NMEA decoder should not be proceeded from firm field lengths. The NMEA definition proceeds from a variable field length. The comma character (',') serves as field disconnecting switch. Numeric values in a field can be represented differently.

In case a field is not sent, it has a length of 0 characters (,).

The check sum „CS“ is covered to two ASCII characters hexadecimal value. „CS“ calculated by XOR operation of each characters in the Sentence between „\$“ and „*“, but excluding „\$“ and „*“.

<CR> carriage return (hex0D)
<LF> linefeed (hex 0A)

Further protocols available on request.



8 Modbus data protocols u[sonic]

Note: Modbus must be configured in default.

This manual covers the general Modbus specification common to all Modbus sensors from LAMBRECHT meteo. The manual allows easy operation of all LAMBRECHT meteo Modbus sensors. Some sensors of the Modbus family offer additional registers and functions, which are described in separate documents via the registers and functions described here. The registers and functions described in this manual are sufficient for general operation of Modbus sensors in a weather station or PLC.

8.1 General

The Lambrecht meteo Modbus sensors follow the specification of the Modbus organization: "MODBUS APPLICATION PROTOCOL SPECIFICATION V1.1b3".

(See www.modbus.org).

8.2 Data encoding

MODBUS uses the "Big-Endian" format for addresses and data. This means that if a value is transmitted with a number format which is larger than a single byte, that the "most significant byte" is sent first.

Example Big-Endian:

Register size value 16 - bits

0x1234 is transmitted in the sequence: 0x12 0x34.

To obtain the real measuring value, divide the received register value by the divisor.

Values of -9999 indicate an internal sensor error.

8.3 Standard configuration - Default

Baud rate: 19200 Baud

Byte frame: 8E1 (1 start bit, 8 data bits, 1 parity bit (even parity), 1 stop bit)

RTU Sensor address: 9

Default addresses of the LAMBRECHT sensors:

Address	Sensor
1	Wind speed
2	Wind direction
3	Precipitation rain[e]
4	THP
5	EOLOS IND; u[sonic]WS6
6	com[b]
7	PREOS
8	ARCO
9	u[sonic]
10	Pyranometer 2nd Class
11	Secondary standard Pyranometer
12	PT100 to Modbus converter (temperature)
13	u[sonic]WS7



8.4 Available Modbus commands

The LAMBRECHT Modbus sensors support the following commands:

- “Read Holding Register” command: 0x03 (descriptive sensor data registers)
- “Read Input Register” command: 0x04 (measured values registers)
(every measured value is to be requested individually)
- “Write Multiple Register” command: 0x10 (Write to configuration registers)

8.5 Instantaneous values / realtime values (Input Register)

The following measured values are provided:

Register address	Parameter name	Unit	Divisor	Quantity of registers	Access type
30001	Wind speed	m/s	10	1	Read only
30201	Wind direction	°	10	1	Read only

Example: Retrieve wind speed



LEN 6	Transmission Query =>	Source Master	Dest Slave 13	Function Read Input Register (4)	Func Desk Address=30001, Quantity of Register=1	Checksum OK:C57A
----------	--------------------------	------------------	------------------	-------------------------------------	--	---------------------

LEN 5	Transmission Response <=	Source Slave 13	Dest Master	Function Read Input Register (4)	Func Desk Byte count=2	Data 00 1F	Checksum OK:F9E8
----------	-----------------------------	--------------------	----------------	-------------------------------------	---------------------------	---------------	---------------------

8.6 Period data - Average, maximum and minimum (Input Register)

Register	Parameter name	Unit	Divisor	Quantity of registers	Access type
30002	Wind speed average	m/s	10	1	Read only
30003	Wind speed maximum	m/s	10	1	Read only
30004	Wind speed minimum	m/s	10	1	Read only
30202	Wind direction average	°	10	1	Read only
30203	Wind direction maximum	°	10	1	Read only
30204	Wind direction minimum	°	10	1	Read only

The data are valid for the period between the current request and the previous request. The maximum range of a period is 1 hour. Recalling the average value of a minimum, maximum and average group will erase the appropriate registers.

Retrieve the values of a group in the sequence minimum, maximum, average.

Use command: 0x03



Example: Retrieve wind speed (min. max. avr.) and erase the register content

01	04	75	34	00	01	6A	08	01	04	02	00	00	B9	30	01
04	75	33	00	01	DB	C9	01	04	02	00	D6	38	AE	01	04
75	32	00	01	8A	09	01	04	02	00	14	B9	3F			

LEN 6	Transmission Query =>	Source Master	Dest Slave 1	Function Read Input Register (4)	Func Desk Address=30004, Quantity of Register=1	Checksum OK:86A
LEN 5	Transmission Response <=	Source Slave 1	Dest Master	Function Read Input Register (4)	Func Desk Byte count=2	Data 00 00 Checksum OK:30B9
LEN 6	Transmission Query =>	Source Master	Dest Slave 1	Function Read Input Register (4)	Func Desk Address=30003, Quantity of Register=1	Checksum OK:C9DB
LEN 5	Transmission Response <=	Source Slave 1	Dest Master	Function Read Input Register (4)	Func Desk Byte count=2	Data 00 D6 Checksum OK:AE38
LEN 6	Transmission Query =>	Source Master	Dest Slave 1	Function Read Input Register (4)	Func Desk Address=30002, Quantity of Register=1	Checksum OK:98A
LEN 5	Transmission Response <=	Source Slave 1	Dest Master	Function Read Input Register (4)	Func Desk Byte count=2	Data 00 14 Checksum OK:3FB9

8.7 Descriptive sensor parameter registers (Holding Register)

Register	Parameter name	Quantity of registers	Remark	Access type
40050	Device identification number (15 characters)	8 (2 characters in each register)	The returned data are in form of a 16 byte null terminated string	Read only
40100	Serial number (11 characters)	6 (2 characters in each register)	The returned data are in form of a 12 byte null terminated string	Read only
40150	Firmware version (up to 25 characters)	13 (2 characters in each register)	The returned data are in form of a 26 byte null terminated string	Read only

Example: Retrieve the device identification number

(The identification number shown in the example is sensor-dependent. It is only used here for demonstration purposes).

0D	03	9C	72	00	08	CA	8B	0D	03	10	30	30	2E	31	36	□□□□□□□□□□□□□□□□
34	38	30	2E	30	30	31	31	33	30	00	E8	6B				00.16480.000130□□□□

LEN 6	Transmission Query =>	Source Master	Dest Slave 13	Function Read Holding Register (3)	Func Desk Address=40050, Quantity of Register=8	Checksum OK:8BCA
LEN 19	Transmission Response <=	Source Slave 13	Dest Master	Function Read Holding Register (3)	Func Desk Byte count=16	Data 30 30 2E 31 36 34 38 30 2E 30 30 31 31 33 30 00 Checksum OK:6BE8



8.8 Configuration registers (Holding Register)

Register	Parameter name	Allowed values	Quantity of registers	Access type
40001	Modbus device address		1	Write only
40200	Baud rate	96 = 9600 192 = 19200 384 = 38400	1	Write only
40201	Parity	1 = even 0 = none	1	Write only

The device must be restarted after each change of a setting!

Example: Change the RTU address from 4 to 1

05	10	9C	41	00	01	02	00	01	06	48	05	10	9C	41	00
01	7E	09													

LEN 9	Transmission Query =>	Source Master	Dest Slave 5	Function Write Multiple Register (16)	Func Desk Address=40001, Quantity=1	Byte count 2	Register values 00 01	Checksum OK:4806
LEN 6	Transmission Response <=	Source Slave 5	Dest Master	Function Write Multiple Register (16)	Func Desk Address=40001, Quantity=1	Checksum OK:097E		

8.9 Autoconfiguration

All Lambrecht Modbus sensors offer the experienced user the possibility to implement an auto-configuration in his Modbus master based on additional information stored in the sensor.

The necessary information can be found in the document "Lambrecht_Modbus_Autoconfiguration".



9 SDI-12 Interface



SDI-12 has to be preconfigured ex works.

Please specify when ordering: Id-No. 97.16470.000002 Configuration SDI-12

The communication using SDI-12 protocol via SDI-12 interface is based on the 'SDI-12 A Serial-Digital Interface Standard for Microprocessor-Based Sensors, Version 1.4, 2017'. The u[sonic] can be used in bus mode parallel to other u[sonic].

The following subset of SDI-12 commands were implemented into the u[sonic].

For more information on the SDI-12 protocol, please refer to the standard documentation mentioned above or the website www.SDI-12.org.

Implemented SDI-12 commands:

Command	Function	Answer of the sensor
a!	Acknowledge Active	a<CR><LF>
a!	Send Identification	allccccccmmmmmmvvvx...xx<CR><LF>
aAb!	Change Address	b<CR><LF>
aC!	Start Concurrent Measurement	atttn<CR><LF>
aCC!	Start Concurrent Measurement and Request CRC checksum	atttn<CR><LF>
aD0!	Send Data (Buffer 0)	a<data><CR><LF> a<data><CRC><CR><LF>
aV!	Start Verification	atttn<CR><LF>
aX!	Resetting the Addresses	a<CR><LF>

a = address of the respective sensor;

Standard sensor address = 0

SDI-12 commands always start with the address of the appropriate sensor. Therefore all other sensors on the same bus will ignore these commands. SDI-12 commands end with '!'. All answers from sensors start with its address, too, but end with the ASCII characters 'Carriage Return' <CR> and 'Line Feed' <LF>.

The SDI-12 protocol is based on the ASCII character set. The baud rate of the SDI-12 protocol is 1200 Bd and has the byte frame format:

- 1 start bit
- 7 data bits (least significant bit transmitted first)
- 1 parity bit (even parity)
- 1 stop bit.

Acknowledge Active - a!

This command ensures that the sensor responds to requests. Basically it asks the sensor to confirm that it is connected to the bus.

The sensor returns its address and <CR><LF>.



Syntax

Command	Answer
a! a – Sensor address ! – End of command	a<CR><LF> a – Sensor address <CR><LF> – End of answer

Example:

Command	Answer
0!	0<CR><LF>
1!	1<CR><LF>

Send Identification - a!

The command **a!** is used to ask the sensor for its model number and firmware version.

Syntax

Command	Answer
a! a – Sensor address ! – Command "Send Identification"	a14LMGmbH151647011.1<CR><LF> a – Sensor address a14LMGmbH151647011.1 14 – 2 characters SDI-12 version-No. 14 = version 1.4 LMGmbH15 – 8 characters manufacturer's (= Lambrecht meteo GmbH) 164701 – 6 characters sensor type 1.1 – Firmware version <CR><LF> – End of answer
! – End of command	

Example:

Command	Answer
0!	014LMGmbH1514582S1.1<CR><LF>
1!	114LMGmbH1514582D1.1<CR><LF>

Change address - aAb!

The factory setting for the address is "0".

If there are several sensors connected to one bus, the sensor address can be changed with the command **aAb!**.

The address is always a single ASCII character. Standard for addresses are the ASCII characters "0" to "9" (decimal 48 to 57). If there are more than 10 sensors connected to one bus, using the characters "A" to "Z" (decimal 65 to 90) and "a" to "z" (decimal 97 to 122) is allowed. The sensor answers with its new address and <CR><LF>.

After the address is changed, one should not send further commands to the sensor for a period of one second (see also "SDI-12 Standard, Version 1.4, 2017").

Syntax

Command	Answer
aAb! a – Old sensor address A – Command 'Change Address' b – New sensor address ! – End of command	b<CR><LF> b – New sensor address <CR><LF> – End of answer



Example:

Command	Answer
0A1!	1<CR><LF>

Start Concurrent Measurement - aC!

The "Concurrent Measurement" enables the data logger to measure simultaneously with multiple sensors on the same bus. The "aC!" command requests the sensor to process the available measurement data and write them to an output string. Unlike the standard sensors described in the SDI-12 documentation, the u[sonic] measures continuously. This is why the u[sonic] always responds with "a000". The data is therefore immediately available. This is also the reason why the u[sonic] does not send a "service request" and ignores measurement interruption commands. The data can be retrieved with the command "aD0!" (see below under "Send data"). The data is not overwritten until the next "C" or "M" command and can be retrieved several times.

Syntax

Command	Answer
aC! a – Sensor address C – Command 'Start Concurrent Measurement' ! – End of command	a00004<CR><LF> a – Sensor address 000 – Seconds the sensor needs until the measured data can be returned (= 0 s – Data immediately available) 4 – Number of provided measured data <CR><LF> – end of answer

Example:

Command	Answer
1C!	100004<CR><LF>

The measured data can be requested with the command aD0! (see "Send Data").

Start Concurrent Measurement and Request - CRC aCC!

Same command as "aC!" but in addition to the generated data the sensor returns a 3-digit checksum. For information on how the CRC checksum gets generated, please consult 'SDI-12 Standard Version 1.4, 2017, chapter 4.4.12'.

Syntax

Command	Answer
aCC! a – Sensor address C – Command 'Start Concurrent Measurement' C – Request for transmission of the CRC checksum ! – End of command	a00004<CR><LF> a – Sensor address 000 – Seconds the sensor needs until the measured data can be returned with "CRC" (= 0 s – Data immediately available) 04 – Number of provided measured data <CR><LF> – End of answer

Example:

Command	Answer
1CC!	100004<CR><LF>



Send Data - aD0!

The data requested by the sensor with the commands "C" or "M" can be retrieved with the command "aD0!". The sensor uses the corresponding signs ("+" or "-") as field separators. If the data was requested with a "CC" or "MC" command, a CRC checksum is also returned. For more information on how to generate this CRC checksum, see "SDI-12 Standard, Version 1.4, 2017, chapter 4.4.12".

After the measurement, the data is stored in the buffer "D0" and retrieved with the command "aD0!".

Definition SDI-12 u[sonic]

C! and CC!

	No.	Parameter	Description	Unit
D0!	1	wind speed	instantaneous value	m/s
	2	wind speed	minimum value	m/s
	3	wind speed	maximum value	m/s
	4	wind speed	average value	m/s
	5	wind direction	instantaneous value	deg
	6	wind direction	minimum value	deg
	7	wind direction	maximum value	deg
	8	wind direction	average value	deg
D1!	9	acoustic virtual temperature	instantaneous value	°C
	10	acoustic virtual temperature	minimum value	°C
	11	acoustic virtual temperature	maximum value	°C
	12	acoustic virtual temperature	average value	°C
D2!	13	status code	8 bit value	
	14	error code	8 bit value	

Minimal, maximum and average value refer to the time since last C! or CC! command.

Syntax for measurements with command "aC!" or "aM!"

Command

Answer

aD0!

a – Sensor address

D – Command 'Send Data'

0 – Request for the data in buffer 0

or

1 = buffer 1

2 = buffer 2

! – End of command

a<values><CR><LF>

a – Sensor address

<values> – Requested data separated by resp. sign ("+" or "-")

<CR><LF> – End of answer

Example:

Command

Answer

0C!

000004<CR><LF>

0D0!

0+0.1+0.1+0.1+0.1<CR><LF>



Syntax for measurements with command "aCC!" or "aMC!"

Command

Answer

aD0!

a – Sensor address

D – Command 'Send Data'

0 – Request for the data in buffer 0

or

1 = buffer 1

! – End of command

a<values><CRC><CR><LF>

a – Sensor address

<values> – Requested data separated by
resp sign ("+" or "-")

<CRC> – 3-digit CRC checksum

<CR><LF> – End of answer



10 Technical Data

(16470) Combined Ultrasonic Wind Sensor u[sonic]
ID 00.16470.100000

Modbus and SDI-12 have to be preconfigured ex works.

Please specify when ordering:

ID 97.16470.000001 Configuration Modbus

ID 97.16470.000002 Configuration SDI-12

Measurement range: wind direction: 0...359.9°
wind speed: 0...75 m/s

Strongest wind impact velocity: 100 m/s

Accuracy: wind direction: < 2° (> 1 m/s) RMSE;
wind speed: 0.2 m/s RMSE
(v < 10 m/s) 2 % RMSE
(10 m/s < v < 65 m/s)

Resolution: wind direction: 0.1°
wind speed: 0.1 m/s

Response threshold: 0.1 m/s (adjustable for wind direction)

Output: RS 485; analogue: 4...20 mA
(0...65 m/s); other scalings on request)

Outputs on request: RS 422; SDI-12; analogue: 0...20 mA;
0...5 V; 0...10 V

Protocols: NMEA 0183; WIMWV; WIMTA

Protocols on request: SDI-12; Modbus RTU

Measuring rate: 0.1...10 Hz;
(internal measurement 50 Hz)

Operating conditions: -40...+70 °C (with heating
-50...+70 °C); 0...100 % r. h.

Supply voltage: without heating: 6...60 VDC
or 12...42 VAC;
with heating: 24 V AC/DC ± 20 %

Current consumption: sensor: typically 45 mA at 24 VDC and
deactivated analog output;
heating max. 10 A at 24 V AC/DC

Measuring principle: ultrasound

Heating data: configurable (factory-setting):
60 W / 120 W / 240 W (standard)

Dimensions: Ø 199 mm; height 149 mm

Housing: seawater resistant aluminium;
IP 66; IP 67

Weight: approx. 2 kg

Standards

- NMEA 0183
- VDE 0100
- Low voltage guide line: 72/23 EWG
- EMC/EMI:
DIN EN 60945 and DIN EN 61000-4-2, -3, -4, -5, -6, -11
- Protection class: DIN EN 60529

Accessories: (please order separately)

Sensor Cable, 15 m, 8-pole bayonet plug
Id.-No. 32.16470.060000

Options:

(95800) met[LOG] Serial Data Logger
Id.-No. 00.95800.010000

For integration of u[sonic] into the house-internal network
(LAN), incl. web browser

as well as

Indicator unit Meteo-LCD
Data logger Ser[LOG]
Mast and power supply unit

11 Disposal

LAMBRECHT meteo GmbH is listed and registered at the
Stiftung Elektro-Altgeräte Register ear under:

WEEE-Reg.-No. DE 45445814

In the category of monitoring and control instruments, device
type: "Monitoring and control instruments for exclusively com-
mercial use".

Within the EU



The device has to be disposed according
to the European Directives 2002/96/EC and
2003/108/EC (Waste Electrical and Elec-
tronic Equipment). Do not dispose the old
device in the household waste! For an
environmentally friendly recycling and dis-
posal of your old device, contact a certified
disposal company for electronic waste.

Outside the EU

Please follow the regulations in your country regarding the
appropriate disposal of waste electronic equipment.



Quality System certified by DQS according to
DIN EN ISO 9001:2015 Reg. No. 003748 QM15

Subject to change without notice.

u_sonic_b-de.indd 35.22

Lambrecht meteo GmbH
Friedländer Weg 65-67
37085 Göttingen
Germany

Tel +49-(0)551-4958-0
Fax +49-(0)551-4958-312
E-Mail info@Lambrecht.net
Internet www.Lambrecht.net