



Features

- Precipitation sensor for automatic weather stations
- Exchangeable, weighing tipping bucket system according to Joss-Tognini
- 2 cm³ (2 g water) tipping bucket for precise precipitation measuring in regions with normal rain falls
- 4 cm³ (4 g water) tipping bucket for precise precipitation measuring in regions with heavy rain falls/ tropical rain
- Connectable to external data logger, e. g. TROPOS
- Winter-fit model (15189 H) with electronically controlled 2-circuit heating
- Weatherproof materials (anodized aluminium, stainless steel) guarantee a long durability
- Funnel according to the WMO Standard No. 8



Function

The weighing precipitation sensor (15189) measures the rain quantity by a tipping bucket developed by Joss-Tognini, the bearings of which have been arranged for low friction. Errors that normally occur due to incomplete draining because of surface tension are automatically compensated by the specific form of the tipping bucket.

The tipping bucket can hold 2 cm³ (2 g) resp. 4 cm³ (4 g) of water. The collecting surface of 200 cm² (WMO standard) means that one bucket charge is equivalent to a precipitation rate of 0.1 mm resp. 0.2 mm per square meter.

If the bucket is tipped, the reed contact that is integrated in the sensor will be closed. This pulse output can be electrically scanned, remotely transmitted and recorded.

A bounce-free signal can be achieved by using the corresponding electrically connection. Otherwise the signal of the reed contact can be used directly, not bounce-free, if this function will be carried out by an appropriate data logger (e. g. Ser[LOG]).

The precipitation sensor (15189) is mounted on a pedestal that is equipped with a connection piece and are attached to a tube with an outside diameter of 60 mm.

For application in snowfall regions the heater equipped model (15189 H) ensures all-year-round measurement. Two separate controlled heating circuits with lowest hysteresis are providing an optimal temperature at which snowing up of the sensor will normally be prevented and evaporation from the heated surfaces will be minimized.

The precipitation sensor (15189) is made of weather-resistant aluminium and stainless steel. This ensures a long durability.

These high-tech precipitation sensors comply with the regulations WMO.

Dimensional drawing

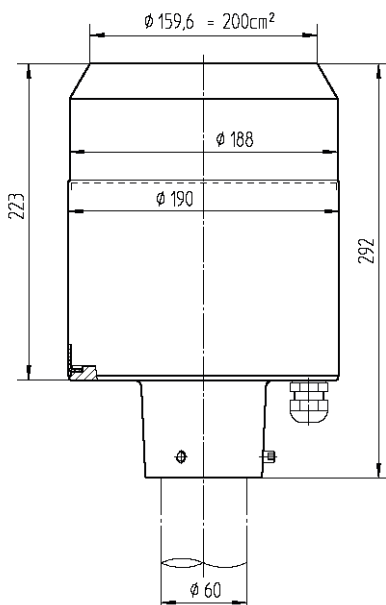

Installation

Mounting of the sensor

The **precipitation sensor (15189)** must be mounted on a tube or pole with an outside diameter of 60 mm. A metallic extension tube with a minimum length of 100 mm is recommended, if a wooden pole is used.

For easy adjustment place a spirit-level on the upper measuring edge.

! Attention! Do not damage the measuring edge!

Place the **precipitation sensor (15189)** on the end of the pole until it fits in. By using the provided allen key (4 mm), tighten the screws in the mounting pedestal evenly. Adjust the upper measurement edge to an exact horizontal position. By doing this, the tipping bucket will automatically be positioned vertically inside the device and will work symmetrically.

Dismounting of the protective covering

Loosening the screw with the provided 3 mm allen key until the protective covering can be turned right to the stop position and take off upward then.

Assembly of the tipping bucket

! To avoid damage to the tipping bucket during transport, it is separately packed and should be inserted in the precipitation sensor (15189) on site only after mounting the gauge on the mast.

For the assembly first you must remove the protective covering.

! Attention!
When fitting the tipping bucket, proceed with utmost caution so that the sharp edges of the tipping bucket are not damaged and the middle wall is not bent!

During operation the tipping bucket lies on the precision bucket bearings. To reduce the friction the bearings are made of abrasion-resistant delrin.

The mounted tipping bucket is secured against eventual changes of position by means of two plates.

To insert the tipping bucket, first the relocatable locking plate **C** must be pushed back.

Now insert the tipping bucket **F**. Make sure that the magnet **E** attached at the middle wall of the tipping bucket rests under the capsule with the embedded reed contact **D**.

Finally the tipping bucket must be secured by pushing back the relocatable locking plate **C**.

Mounting of the protective covering

When mounting the protective covering, please make sure that the sign "close <-- --> open" (close < - > to) is positioned above the fixing screw. Especially when using the heated version you have to pay attention to this step. This avoids that the cable of the protective covering heating may block the tipping bucket.



Attention! In order to protect the tipping bucket the dirt spiral must be inserted in the collecting funnel.

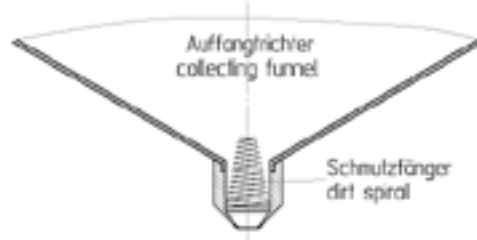
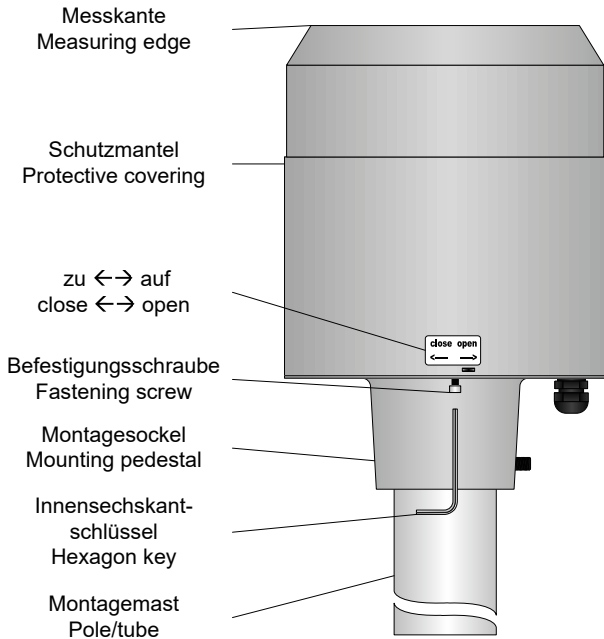

- A: Tipping bucket bearings
- B: Fixed locking plate
- C: Relocatable locking plate
- D: Reed contact
- E: Magnet (here shown through inclination of the bucket)
- F: Tipping bucket

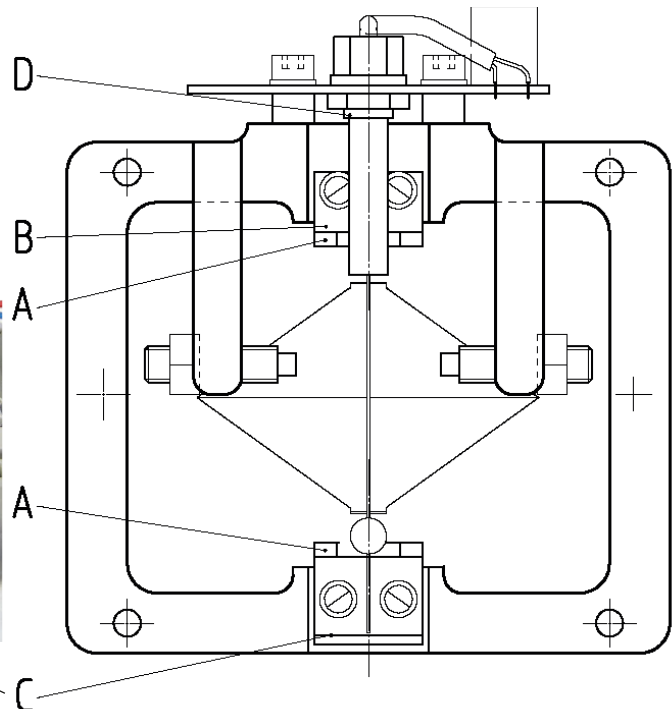
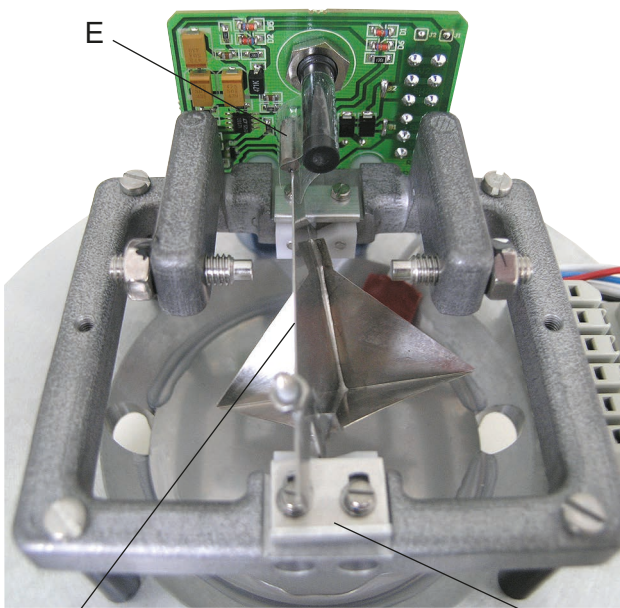



Electrical connections

The sensor will be connected to the cable by leading the cable through the conduit gland to the connector inside the sensor housing. Recommended cable type:

2 (4) x AWG 20 CU L sw;
diameter approx. 5.1 mm

The cable should not be longer than 11 m.



When the cable is transferred inside the ground it is recommended to protect the cable with a protecting plastic tube.

Use of the bounce-free output signal (see figure page 6)

The usual circuit of the precipitation sensors is suitable for connection to data loggers without an own bounce-free impulse input. For this application the clamps 3 and 4 are used.



Make sure, that the current supply for the precipitation sensor with usual circuit is not less than 100 μ A (see also technical data).

Use of the direct output signal (see figure page 7)

This circuit variant of the precipitation sensors is suitable for connection to data loggers with a bounce-free impulse input. For this application the clamps 1 and 6 are used. In this case the current supply of the electronics with 100 μ A is not necessary.

The LAMBRECHT meteo data logger TROPOS is equipped with such a bounce-free input. Thus the direct output signal of the reed contact is used. An additional benefit is a low-current effect.

(15189 H) Version with heating

Version i. e. with a controlled 2-circuit heating for collecting funnel and drain pipe.

Electrical connections

For the connection of the heating a 4-core cable is required, which has to apply and connect to the power supply unit according to the *connecting diagrams* with heating.

The **function of the heating elements** can be tested also at ambient temperatures above the control temperature of the solid-state thermostat. For this simple test a regular magnet has to be held close to the blue housing of the switching circuit. When reaching a surface temperature of approximately 50 °C the current will be switched off.

Both blue thermostat modules are fitted internally on the funnel surface as well as on the bottom of the housing.

The operational conditions will be indicated with colored light-emitting diodes (LED) on the thermostatic module:

green: supply voltage

red: heating on

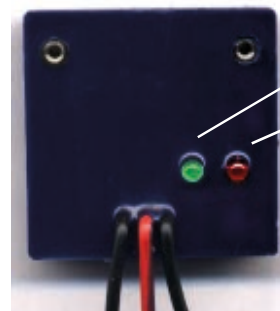

green
red



Initial operation

If the sensor system has been completely mounted and electrically assembled, the sensor will be ready for operation. An operational check has to be performed.

Maintenance and operational check

The precipitation sensor is nearly maintenance-free. The sensor should be checked and cleaned periodically in order to guarantee its proper operation, because dirt accumulation may cause errors of measurement. The time interval of cleaning depends on the local conditions.

The **operational check** of the sensor may be performed by the use of artificial precipitation. The volume of a 200 cm³ resp. 400 cm³ (by 4 cm³ buckets) test container of water must be piped into the collecting funnel through a nozzle in such a way that the drops fall into the funnel beside the outlet. The nozzle of the test container (approx. diameter 0.6 mm) should be adjusted to allow a complete water run out into the funnel within 10 to 12 minutes.

After the artificial precipitation has gone through, 100 ± 2 bucket tipplings should have counted.

Rinse the sensor thoroughly for cleaning. Clinging particles of dirt in the collecting funnel or outlet pipe may be removed with a piece of wood.

If unsatisfying measurement results occur after this cleaning procedure, the tipping bucket should be disassembled for cleaning.



Absolute care must be taken not to damage the tipping bucket!

The dismantled tipping bucket can be cleaned by placing it in warm water with some scouring material and by carefully scraping off unwanted dirt by using a small piece of wood.

Warranty

Please note the loss of warranty and non-liability by unauthorised manipulation of the system. You need a written permission from LAMBRECHT meteo GmbH for changes of system components. These activities must be operated by a qualified technician.

The warranty does not cover:

1. Mechanical damages caused by external impacts (e. g. icefall, rockfall, vandalism).
2. Impacts or damages caused by over-voltages or electromagnetic fields which are beyond the standards and specifications in the technical data.
3. Damages caused by improper handling, e. g. by wrong tools, incorrect installation, incorrect electrical installation (false polarity) etc.
4. Damages which are caused by using the device beyond the specified operation conditions.

Disposal

LAMBRECHT meteo GmbH is listed and registered at the Stiftung Elektro-Altgeräte Register ear under:

WEEE-Reg.-No. DE 45445814

In the category of monitoring and control instruments, device type: "Monitoring and control instruments for exclusively commercial use".

Within the EU

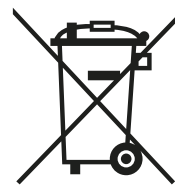

The device has to be disposed according to the European Directives 2002/96/EC and 2003/108/EC (Waste Electrical and Electronic Equipment). Do not dispose the old device in the household waste! For an environmentally friendly recycling and disposal of your old device, contact a certified disposal company for electronic waste.

Outside the EU

Please follow the regulations in your country regarding the appropriate disposal of waste electronic equipment.

Connecting diagrams for use of the bounce-free signal output (standard)

with heating

without heating

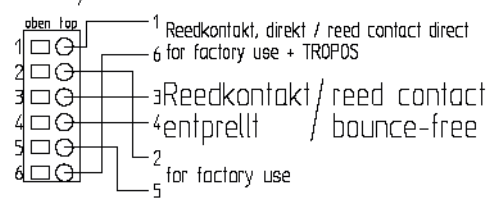
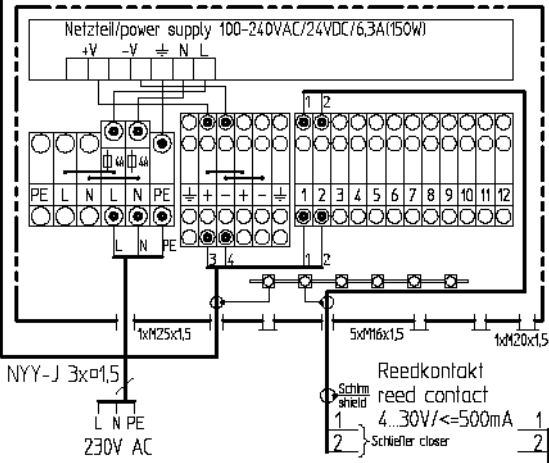
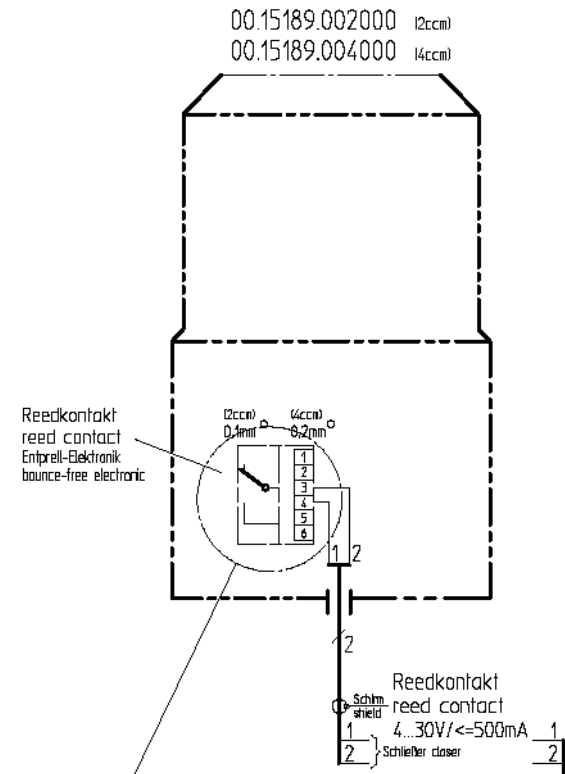
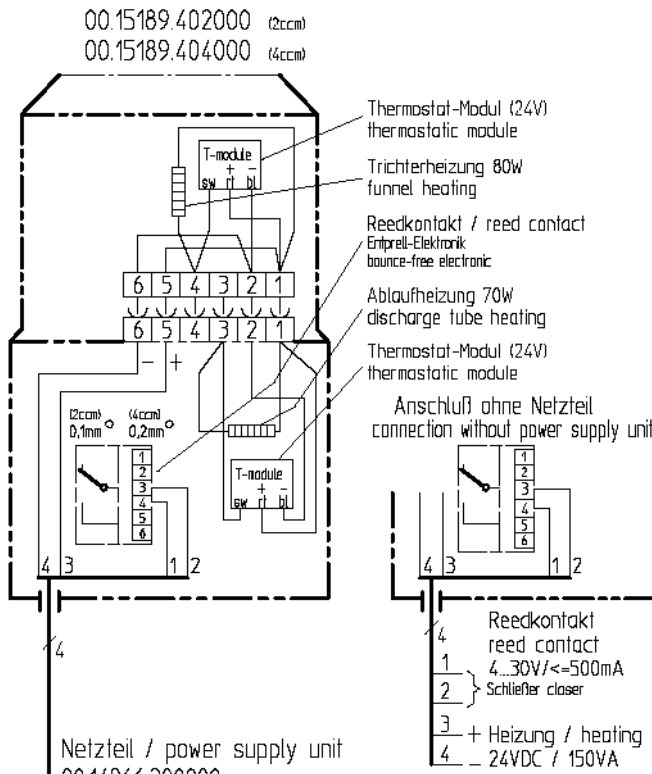

AWG-cable colorcode

1	bik-black
2	brn-brown
3	red-red
4	ora-orange

**Zweileiteranschluß
 TWO-WIRE-INTERFACE**

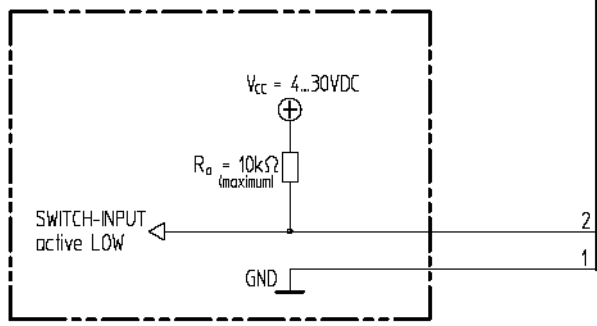

**Zweileiteranschluß
 TWO-WIRE-INTERFACE**

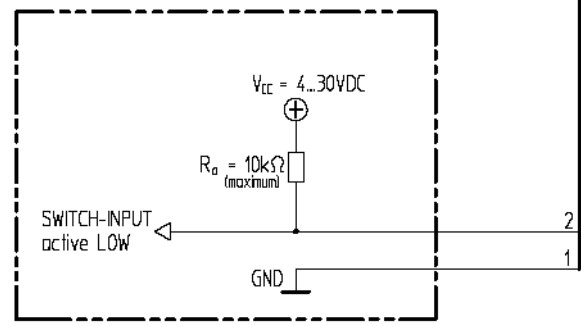



Connecting diagrams to data logger TROPOS

with heating

00.15189.402000 (2ccm)
 00.15189.404000 (4ccm)

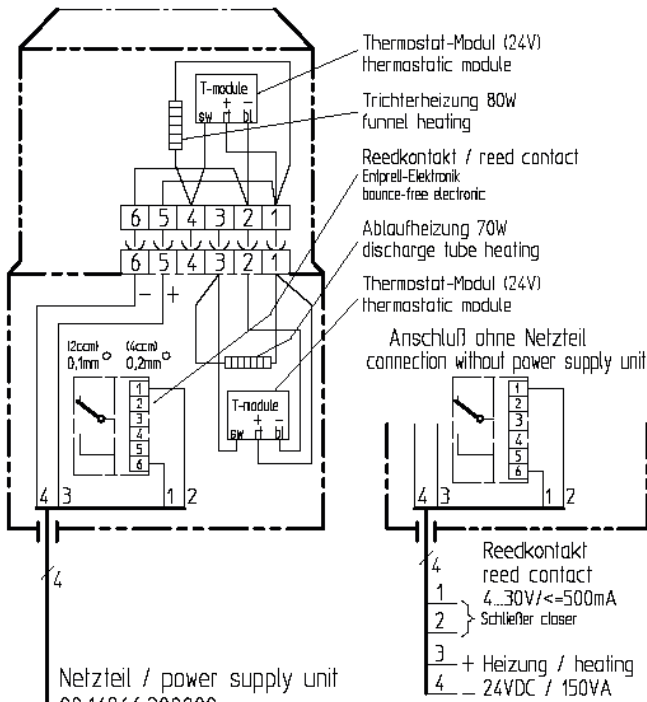

without heating

00.15189.002000 (2ccm)
 00.15189.004000 (4ccm)

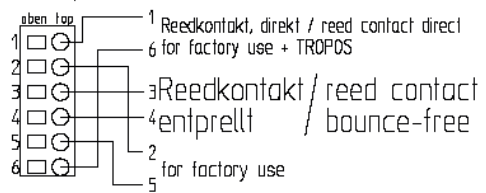
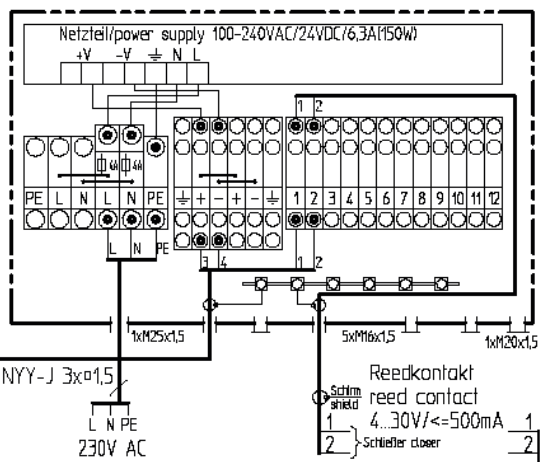
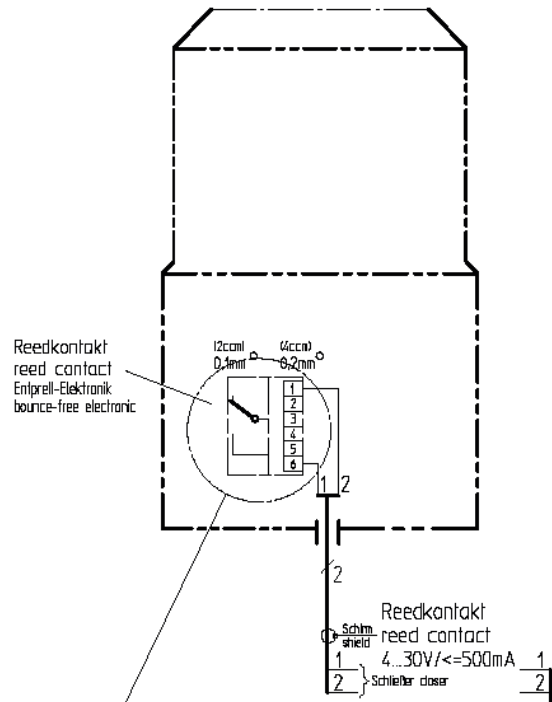

AWG-cable colorcode

1	blk-black
2	brn-brown
3	red-red
4	ora-orange

Datenlogger / datalogger
 TROPOS No. 00.95666.100000

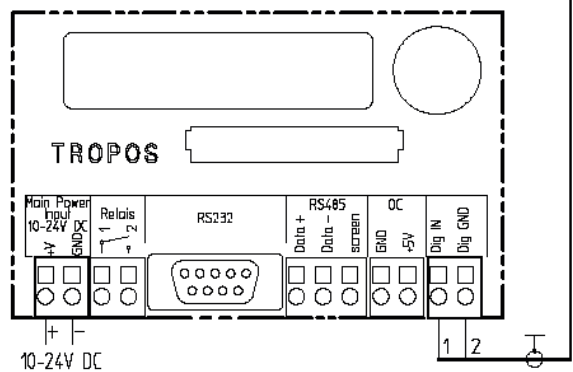

Datenlogger / datalogger
 TROPOS No. 00.95666.100000

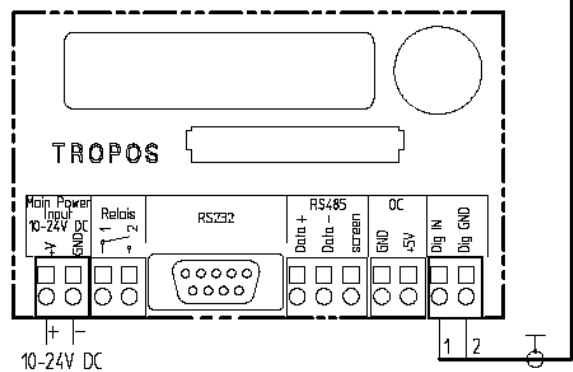



Technical data

(15189) Version with 2 cm³ bucket, unheated

Id-No.	00.15189.002 000
Measuring principle	weighing tipping bucket designed acc. to Joss-Tognini
Measuring range	2 cm ³ (2 g water) - volume of bucket 0...8 mm/ min
Resolution	0.1 mm
Accuracy	± 2 % with intensity correction *)
Range of application	0...+70 °C - measuring
Pulse output	reed contact · polarity protected · bounce-free signal
Current consump.	max. 100 µA · typical 50 µA
Supply voltage	4...30 VDC
Load	max. 30 VDC/ 0.5 A
Dimensions	see dimensional drawing
Suitable for mounting	Ø 60 mm
Weight	approx. 3 kg
Standards	WMO-No. 8 · VDI 3786 Bl. 7 EN 50081/82 · VDE 0100

(15189 W4) Version with 4 cm³ bucket, unheated

Data like (15189), but for very high precipitation intensity

Id-No.	00.15189.004 000
Measuring range	4 cm ³ (4 g water) - volume of bucket 0...16 mm/ min
Resolution	0.2 mm

(15189 H) Version with 2 cm³ bucket, heated

Data like (15189) 00.15189.002 000, but in additional with controlled 2-circuit-heating:

Id-No.	00.15189.402 000
Heating data	Electronic controlled, dual-circuit
Accuracy	4 °C ± 2 °C, controlled temperature within a range of -20...+4 °C
Heating power	80 W (funnel) 70 W (outlet/ tipping bucket)
Supply voltage	24 VDC/ 150 W
Range of application	-20...+70 °C (no icing, no snowdrift)

(15189 H W4) Variety with 4 cm³ bucket, heated

Date like (15189 W4) 00.15189.004 000, but in additional with controlled 2-circuit-heating, like (15189 H)

Id-No.	00.15189.404 000
---------------	-------------------------

*) The intensity compensation is not performed in the sensor but in the data logger, such as Ser[LOG]. met[LOG], PreLOG..

Accessories

(1518 S4)	Stainless steel mast Id-No. 00.15180.400 000
(1518 S8)	Stainless steel concrete foundation mast Id-No. 00.15180.800 050
(1518 U21a)	Protection ring Id-No. 32.15180.021 010
(1518-49)	Dirt pan (spare part) Id-No. 33.15180.049 000
(15188 U60i)	Connecting cable sensor/ data logging L=7 m Id-No. 32.15188.060 090 (2-core)

For versions with heating (H-versions)

(1496 S62)	Power supply unit Id-No. 00.14966.200 000
(15188 U61b)	Connecting cable sensor/ power supply unit for mounting at the mast L ≈ 1 m; Id-No. 32.15188.061 020 (4-core)
(14622 S22)	Holder for power supply unit on the mast Id-No. 32.14622.220 000
(15188 U61i)	Connecting cable sensor/ power supply unit L = 7 m; Id-No. 32.15188.061 090 (4-core)

Safety instructions

This system is designed according to the state-of-the-art accepted safety regulations. However, please note the following rules:

1. Before setting into operation, please read all appropriate manuals!
2. Please take notice of internal and state-specific guidelines and/or rules for the prevention of accidents (e.g. the professional association). If necessary ask your responsible safety representative.
3. Use the system according to the manual's regulations only.
4. Always leave the manual at hand at the place of work of the system.
5. Use the system in technically correct conditions only! You have to eliminate influences immediately which impair the security .
6. Please note the loss of warranty and non-liability by unauthorized manipulation of the system. You need a written permission of the LAMBRECHT meteo GmbH for changes of system components. These activities must be operated by a qualified technician.
7. Prevent the ingress of liquids into the devices without permission.